



2022 | 2023

 elica
aria nuova

68 NIKOLATESLA ALPHA
56 NIKOLATESLA FIT
52 NIKOLATESLA FIT XL
60 NIKOLATESLA FIT 3Z
72 NIKOLATESLA FLAME
48 NIKOLATESLA LIBRA
41 NIKOLATESLA ONE
36 NIKOLATESLA ONE HP
64 NIKOLATESLA PRIME S
47 NIKOLATESLA SWITCH
42 NIKOLATESLA SWITCH GLOW
30 NIKOLATESLA UNPLUGGED

198 ACUTA
176 ADÈLE
217 ADÈLE ISLAND
141 APLOMB
154 BELT
166 BIO
208 BIO ISLAND
147 BLOOM
142 BLOOM-S
309 BOXIN
307 BOXIN ADVANCE
302 BOXIN DRY
301 BOXIN NO DRIP
308 BOXIN PLUS
331 CIAK
330 CIAK S
191 CIRCUS
249 CLOUD SEVEN
187 CRUISE
311 CT35 PRO
275 EASY UX
266 ÈDITH
333 ELITE 14
332 ELITE 35
153 ELLE
326 ERA
325 ERA C
324 ERA S
335 ESTRAIBILE
189 FLAT GLASS
323 FOLD
322 FOLD S
181 GALAXY
219 GALAXY ISLAND
288 GETUP
329 GLASS OUT
160 HAIKU
164 HAIKU 32
204 HAIKU ISLAND
207 HAIKU ISLAND 32
320 HIDDEN 2.0
312 HIDDEN 2.0@
319 HIDDEN ADVANCE
245 HILIGHT GLASS
247 HILIGHT-X
199 HYDRA
220 IKONA

280 IKONA LIGHT
104 IKONA MAXXI PURE
240 ILLUSION
256 INTERSTELLAR
180 JOY
218 JOY ISLAND
284 JUNO
285 JUNO URBAN
334 KREA
227 KUADRA ISLAND
321 LANE
327 LEVER
183 LOL
234 LULLABY
150 MAJESTIC
149 MAJESTIC NO DRIP
171 METEORITE
213 METEORITE ISLAND
196 MISSY
215 MOON ISLAND
112 NUAGE
151 OM AIR
92 OPEN SUITE
86 OPEN SUITE SUPERIOR
295 PANDORA
279 PIX
136 PLAT
190 REEF
224 REEF ISLAND
201 RUBINO CORNER
122 RULES
261 SEASHELL
157 SHEEN-S
262 SHINING
159 SHIRE
158 SHY-S
239 SKYDOME
186 SPOT NG
184 SPOT PLUS
222 SPOT PLUS ISLAND
185 SPOT URBAN
192 STONE
156 STRIPE
155 STRIPE URBAN
130 SUPER PLAT
172 SWEET
200 SYNTHESIS
195 TAMAYA 2.0
182 THIN
221 THIN ISLAND
194 TONDA
188 TRIBE
223 TRIBE ISLAND
193 TUBE PRO
226 TUBE PRO ISLAND
197 VEGA
152 VERTIGO
270 WAVE UX
116 YE
225 ZENITH

ELICA, UN'ANIMA IN CONTINUA EVOLUZIONE

L'anima di Elica è potente e imprime con gentilezza la sua presenza nel mondo.

Si muove costantemente, non ha confini reali e con passione si evolve con la realtà che la circonda per regalarti il comfort e le emozioni che rendono migliori i momenti quotidiani.

L'anima di Elica vive in ogni prodotto della nostra gamma, lo trasforma in un oggetto tecnologico, dal design accattivante, funzionale.

Questo è il mondo dei prodotti Elica, entra e lasciati ispirare.

ELICA, AN EVER EVOLVING SOUL

Elica's powerful soul gently marks its presence throughout the world.

It is in continuous movement, has no real boundaries and passionately evolves with the reality around it, offering the comfort and emotions that make everyday life better.

Elica's soul lives in each and every product, transforming them into functional, technological and appealing design objects.

This is the world of Elica products, come in and let yourself be inspired.

INDEX

- 8 **ELICA FOR YOU**
- 10 Elica Connect
- 12 Elica Air Treatment
- 14 Elica No Drip
- 16 Caratteristiche di prodotto
Product Features
- 336 **GOOD TO KNOW**
- 338 Accessori
Accessories
- 339 Filtri odori
Odour filters
- 344 Motori remoti
Remote motors
- 347 Filtri grassi
Grease filters
- 352 Approfondimenti performance
Learn more about performance
- 356 Approfondimenti tecnici
Technical informations
- 374 Tu e la cappa
The hood and you
- 378 Etichetta energetica
Energy label
- 379 Garanzia e service
Warranty and service

NIKOLATESLA 26



NIKOLATESLA ALPHA
68



NIKOLATESLA FIT
56



NIKOLATESLA FIT 3Z
60



NIKOLATESLA FIT XL
52



NIKOLATESLA FLAME
72



NIKOLATESLA LIBRA
48



NIKOLATESLA ONE
41



NIKOLATESLA ONE HP
36



NIKOLATESLA PRIME S
64



NIKOLATESLA SWITCH
47



NIKOLATESLA SWITCH GLOW
45



NIKOLATESLA UNPLUGGED
30

ARCH & LIGHTAIR 84



IKONA MAXXI PURE
104
ELICA AIR PURE



NUAGE
112



OPEN SUITE
92
ELICA CONNECT



OPEN SUITE SUPERIOR
86
ELICA CONNECT



YE
116

WALL 120



ACUTA
198



ADÉLE
176



APLOMB
141



BELT
154



BIO
166



BLOOM
147



BLOOM-S
142



CIRCUS
191



CRUISE
187



ELLE
153



FLAT GLASS
189



GALAXY
181



HAIKU
160



HAIKU 32
164



HYDRA
199



JOY
180



LOL
183



MAJESTIC
150



MAJESTIC NO DRIP
149



METEORITE
171



MISSY
196



OM AIR
151



PLAT
136



REEF
190

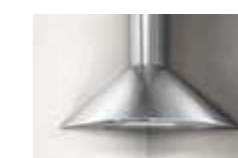

RUBINO CORNER
201



RULES
122



SHEEN-S
157

WALL 



SHIRE
159



STRIPE
156



THIN
182



SHY-S
158



STRIPE
URBAN
155



TONDA
194



SPOT NG
186



SUPER PLAT
130
ELICA CONNECT



TRIBE
188



SPOT PLUS
184



SWEET
172



TUBE PRO
193



SPOT
URBAN
185



SYNTHESIS
200



VEGA
197



STONE
192



TAMAYA 2.0
195



VERTIGO
152

ISLAND 202



ADÉLE ISLAND
217



JOY ISLAND
218



THIN ISLAND
221



BIO ISLAND
208



KUADRA
ISLAND
227



TRIBE ISLAND
223



GALAXY
ISLAND
219



METEORITE
ISLAND
213



TUBE PRO
ISLAND
226



HAIKU ISLAND
204



MOON ISLAND
215



ZENITH
225



HAIKU
ISLAND 32
207



REEF ISLAND
224



IKONA
220



SPOT PLUS
ISLAND
222

CEILING 228



CLOUD SEVEN
249



HILIGHT-X
247



LULLABY
234
ELICA CONNECT



HILIGHT GLASS
245



ILLUSION
240
ELICA CONNECT



SKYDOME
239
ELICA CONNECT

SUSPENDED 254



EASY UX
275



JUNO
284



SHINING
262



ÉDITH
266



JUNO URBAN
285



WAVE UX
270



IKONA LIGHT
280



PIX
279



INTERSTELLAR
256



SEASHELL
261

DOWNDRAFT 286



GETUP
288
ELICA CONNECT



PANDORA
295

BUILT-IN 298



BOXIN
309



ELITE 14
333



GLASS OUT
329



BOXIN
ADVANCE
307



ELITE 35
332



HIDDEN 2.0
320



BOXIN
DRY
302



ERA
326



HIDDEN 2.0 @
312
ELICA CONNECT



BOXIN
NO DRIP
301



ERA C
325



HIDDEN
ADVANCE
319



BOXIN
PLUS
308



ERA S
324



KREA
334



CIAK 2.0
331



ESTRAIBILE
335



LANE
321



CIAK 2.0 S
330



FOLD
323



LEVER
327



CT35 PRO
311



FOLD S
322



ELICA FOR YOU

Il nostro impegno è per te, per la tua casa. Il pensiero di Elica è volto al perfezionamento del prodotto. La nostra passione ci spinge giorno dopo giorno a ideare nuove soluzioni tecnologiche intorno alla vita quotidiana, non solo in cucina, ma anche nel resto della casa. Così nascono le nostre proposte più all'avanguardia per rendere ancora più creativo cucinare e prendersi cura dell'aria in casa.

We are dedicated to you and your home. Elica's vision is focused on perfecting our products. Our passion drives us to continuously study new technical solutions to improve everyday life spent, not only in the kitchen, but in the rest of the house as well. This is how our most avant-garde products were born, making cooking even more creative, while taking care of the air we breathe inside our homes.

ELICA CONNECT



LA GAMMA ELICA CONNECT, PENSATA PER FACILITARTI LA VITA THE ELICA CONNECT RANGE, DESIGNED TO MAKE LIFE EASIER

Elica ti è vicina nella vita di tutti i giorni ed ha creato una gamma di prodotti connessi, controllabili dallo smartphone o tramite l'assistente vocale, che si sposano al meglio con lo stile della tua cucina, grazie al loro design innovativo. Soluzioni tecniche all'avanguardia sono state studiate per semplificare le attività quotidiane, quelle con cui ti prendi cura di te e della tua famiglia ma che portano via tempo ed energie.

Se vuoi proteggere l'aria della casa, Elica Connect lo fa per te e puoi pensare solo a goderti il tuo tempo libero, in pieno relax e senza nessuna preoccupazione.

Elica is at your service in your everyday life and has created a range of connected products controlled by smartphone or via the vocal assistant which fit in seamlessly with the style of your kitchen, thanks to their innovative design. Avant-garde technical solutions have been developed to simplify everyday tasks, the ones with which you take care of yourself and your family, but take up your time and energy.

If you want to protect the air in your home, Elica Connect does it for you and you can concentrate on enjoying your free time, in total relaxation, with no worries.

Tutto a portata di click All just one click away

Elica Connect è un'applicazione semplice e intuitiva, scaricabile in pochi secondi.

Dopo aver registrato il prodotto nella app, avrai l'accesso ad un mondo di servizi ideati per rendere il tuo quotidiano più semplice, in casa, distante da casa o ovunque tu sia. Dalla visualizzazione dello stato dei filtri al funzionamento a distanza della tua cappa, fino alla guida alla manutenzione e altro ancora.

Elica Connect is a simple and intuitive application that can be downloaded in a matter of seconds.

After registering the product on the app, you will be granted access to a world of services designed to make your daily routine easier, at home, far away from home or wherever you are. From viewing the filter status to the remote operation of your hood, as well as the guide to maintenance and much more.



Cosa puoi chiedere al tuo assistente vocale What you can ask your vocal assistant

Il tuo assistente vocale ti permette di accendere e spegnere l'aspirazione della tua cappa, selezionando il livello preferito. Può anche regolare l'intensità e la tonalità della luce. Seguendo le tue indicazioni, imposterà l'illuminazione in base all'atmosfera che vuoi creare, intima e rilassante oppure quella adatta ad un banco cucina dove ogni dettaglio deve essere ben visibile.

Your vocal assistant allows you to switch the hood extraction on and off and to select the preferred speed. You can also adjust the intensity and tone of the light. Following your instructions, it will set the lighting based on the atmosphere you want to create; intimate and relaxing or adapted to a kitchen workbench where every detail must be clearly visible.

Cosa puoi fare con la App Elica Connect What you can do with the Elica Connect app

IMPOSTARE LE LUCI CONFIGURE THE LIGHTS

Si può regolare l'intensità e la potenza della luce della cappa in pochi secondi, modulare la temperatura dei led, da luce calda a luce fredda, allineando l'illuminazione della cappa a quella dell'ambiente, per creare un'atmosfera uniforme in tutta la stanza.

You can adjust the intensity and power of the hood lights in just a few seconds, modulate the temperature of the LEDs from warm to cold light, aligning the lighting of the hood with that of the room to create a uniform atmosphere throughout.

REGOLARE L'ASPIRAZIONE ADJUST EXTRACTION

Oltre all'accensione e allo spegnimento del sistema di aspirazione, a seconda delle esigenze, è possibile regolare la potenza di aspirazione della cappa, anche a distanza. Grazie alla Funzione Timer, la tua cappa si spegne quando lo decidi tu. Si possono usare le regolazioni di default, oppure personalizzare il funzionamento del timer. Inoltre, selezionando la funzione Silent potrai assicurarti un'ottima performance in termini di aspirazione e silenziosità. Chiacchiera con gli amici o goditi la TV mentre prepari il tuo prossimo piatto.

In addition to switching the extraction system on and off based on your requirements, it is possible to adjust the extraction power of the hood, even remotely. Your hood switches off when you decide thanks to the timer function. You can use the default adjustments or customise the timer functions. You can ensure excellent performance in terms of extraction and noise levels by selecting the Silent function. Chat with your friends or watch TV while you are preparing your next dish.

PRENDERTI CURA DEI FILTRI TAKE CARE OF THE FILTERS

Se l'efficienza dei tuoi filtri scende sotto la soglia minima, una notifica ti avvertirà che è necessario pulire, sostituire o rigenerare i filtri della tua cappa, per garantirti le migliori prestazioni e un'aria sempre pulita in casa. La sezione "How to" ti illustra passo dopo passo come estrarre, mantenere e reinserire i filtri, inclusi i passaggi per la pulizia degli stessi. Se il tuo filtro è da sostituire, la app ti porta direttamente alla sezione Elica Shop, dove trovi tutti i filtri compatibili con il modello della tua cappa. Da qui, basta un click per acquistare e ricevere comodamente a casa il filtro, l'accessorio o i prodotti di pulizia eco-friendly.

If the efficiency of your filters falls below the minimum threshold, an alert will notify you that it is necessary to clean, replace or regenerate the filters in your hood to guarantee the best performance and clean air in your home. The "How to" section provides you with a step by step guide on how to remove, maintain and reinsert the filters in your hood, including the steps on how to clean them. If your filter needs replacing, the app will take you directly to the Elica Shop where you can find all the filters that are compatible with your hood model. From here, with just one click, you can purchase and conveniently receive the filter, accessory or eco-friendly cleaning products in your home.

RICEVERE ASSISTENZA RECEIVE SUPPORT

Contattarci è più facile e veloce con la App Elica Connect. L'assistenza Elica sarà subito pronta a risolvere il problema dandoti suggerimenti chiari su come procedere. Inoltre, puoi dimenticarti dei documenti cartacei: all'interno della App Elica Connect, trovi tutto ciò di cui hai bisogno dalla Garanzia al Libretto d'uso e manutenzione. Puoi consultarli quando vuoi senza perdere un secondo del tuo tempo.

Contacting us is easier and faster with the Elica Connect App. Elica support will be instantly on hand to solve the problem by giving you clear suggestions on how to proceed. You can also forget about paper documents because everything you need is in the Elica Connect App, from the warranty to the use and maintenance booklet. You can consult it whenever you want to without losing a second of your time.



Elica e la cura dell'aria in casa

Elica and household air treatment

Le nostre abitudini stanno cambiando, oggi ci fa piacere trascorrere tempo in casa e ciò rende sempre più importante guardare alla qualità di questo spazio per la nostra salute e il nostro benessere. Per questo motivo, la qualità dell'aria negli ambienti domestici è diventato un tema di rilievo e si pone sempre maggiore attenzione alle soluzioni per rendere la casa sicura e piacevole grazie ad un'adeguata ventilazione che elimini i livelli di inquinamento interni.

Elica ha studiato soluzioni personalizzate che coniugano tutte le esigenze riguardanti lo spazio, la qualità dell'aria, l'architettura dell'illuminazione e l'efficienza energetica.

I nostri prodotti accostano il design a funzioni che garantiscono semplicità di utilizzo e uno spazio privo di odori sgradevoli, vapori e sostanze inquinanti.

Our habits are changing: nowadays, we enjoy spending time inside our homes and, as a result, living space quality is a key factor for our health and well-being. For this reason, the air quality inside our homes has become a very important issue, with increasing attention being paid to solutions that make houses safer and more pleasant, thanks to adequate ventilation systems for indoor pollution removal.

Elica has developed some customized solutions to meet any needs, in terms of space, air quality, lighting design and energy savings. Our products combine design and features to guarantee easy usability while removing unpleasant odors, vapors and pollutants from living spaces.

Air Pure

Elica ha creato **Ikona Maxxi Pure**, un prodotto multifunzione progettato per migliorare la qualità dell'aria, senza la necessità di dispositivi aggiuntivi o sistemi di monitoraggio complessi, spesso ingombranti e antiestetici.

Ciò è possibile con lo speciale Combo Pure Filter, un combinato di Hepa e carbone, che cattura gli agenti inquinanti liberando la zona living da odori e allergeni come polvere, peli di animali, pollini, muffe e residui dannosi prodotti da detersivi per la pulizia della casa, pitture e rivestimenti.

Questa tecnologia è in grado di purificare completamente l'aria di un ambiente di 30m² in soli 20 minuti e di lavorare in background nel massimo silenzio.

Il prodotto è stato sapientemente progettato per separare il modulo cappa dal purificatore d'aria senza alcun compromesso in termini di prestazioni e fruibilità e per farli funzionare in modo efficace ed indipendente.

Elica has conceived **Ikona Maxxi Pure**, a multi-functional product designed to improve air quality, without the need for additional devices or complex monitoring systems, which can often be cumbersome and unattractive. This is possible thanks to the special Combo Pure Filter, a combination of Hepa and charcoal, which captures pollutants, thus freeing the living area from odors and allergens such as dust, animal hair, pollen, mold and harmful residues produced by household cleaning detergents, paints and coverings. This technology can completely purify the air in a space of 30m² in only 20 minutes and operates with very low background noise levels. This product has been skillfully designed to separate the hood unit from the air purifier without compromising on performance and usability, to make them work both efficiently and independently.



Airmatic

Hidden Advance, Boxin Advance, Skydome e Illusion sono le innovative cappe che Elica ha voluto dotare di un sensore intelligente in grado di rendere il prodotto completamente automatico e di ripulire l'aria, non solo mentre si sta cucinando, ma in ogni momento della giornata.

Questo speciale sensore, installato all'interno della cappa, monitora la qualità dell'aria in casa ed è in grado di rilevare sia il tipo di cottura e la quantità dei vapori che la presenza di agenti inquinanti e di regolare automaticamente la funzione aspirante per rimuovere cattivi odori e sostanze nocive come solventi per la pulizia, fumo di sigaretta e i composti organici che si trovano nell'aria.

Quando la qualità dell'aria torna ad un livello ottimale, la cappa si spegne da sola evitando qualsiasi spreco di energia.

Questa tecnologia permette di ottenere il miglior equilibrio tra semplicità di utilizzo, efficienza energetica e ottimizzazione del rumore.



Hidden Advance, Boxin Advance, Skydome and Illusion are innovative hoods that Elica has equipped with smart sensors that make the appliance fully automatic, thus capable of cleaning air at any time of the day, not only during cooking.

This special sensor, found inside the hood, monitors indoor air quality and detects both the type of cooking and vapor quantity, as well as the presence of any pollutants, at the same time automatically adjusting extraction to remove unpleasant odors and harmful substances, such as: cleaning solvents, cigarette smoke and organic compounds found in the air. Once air quality is brought back to an ideal level, the hood switches off automatically, thus saving energy.

This technology provides the best balance between user-friendliness, energy efficiency and low noise levels.



Boxin No Drip

La condensa e il vapore in eccesso non saranno più un problema
Condensation and excess vapor are no longer a problem

Quando si utilizza un piano cottura a induzione è frequente la formazione di condensa, fenomeno fisico causato dalla differenza di temperatura tra i fumi caldi generati dalla cottura e le superfici fredde della cappa. Le gocce spesso ricadono sul piano o nelle pentole e possono rovinare i pensili. Inoltre, con il tempo, la presenza di umidità può portare a danneggiare la cappa stessa.
Majestic No Drip, Boxin Dry, Boxin No Drip e Rules sono i modelli studiati da Elica per risolvere queste problematiche. I loro sistemi brevettati inoltre garantiscono maggiore protezione e quindi una vita più lunga alle ante dei mobili della cucina.

When using an induction hob, the formation of condensation is common: a physical phenomenon caused by the temperature difference between cooking fumes and the cold hood surfaces. Drops often fall onto the hob or cookware and may damage the cabinets. Furthermore, the presence of humidity may ruin the hood over time. **Majestic No Drip, Boxin Dry, Boxin No Drip and Rules** are Elica's hood models developed to resolve this problem. Their patented system further guarantees higher protection and therefore, longer lasting kitchen cabinetry doors.



Boxin Dry



Majestic No Drip



Rules

Funzionalità e sistemi brevettati
Patented systems and features



Il design ergonomico e funzionale consente di raggiungere risultati eccezionali in termini di captazione dei fumi per un'aria pulita e sana.
 A seconda del modello, grazie alle speciali griglie inclinate o a un sistema di resistenze che permette al vetro di riscaldarsi, l'acqua di condensa non sgocciola più sul piano cottura, ma viene raccolta in una apposita vaschetta che è facilmente accessibile e può essere rapidamente svuotata, a garanzia di una perfetta igiene e manutenzione del prodotto.



Ergonomic and functional design allows for excellent results, in terms of fume capture for clean and healthy air. Thanks to special tilted grids or a resistance system that heats up the glass, depending on the model, water condensation no longer drips onto to hob and is collected into a specific tray, which is easily accessible, and may be quickly emptied, thus guaranteeing perfect product cleanliness and maintenance.

I prodotti Elica No Drip **Elica No Drip products**

Ad oggi non esiste una prova normata riconosciuta a livello internazionale in termini di "anticondensa". Elica ha creato un proprio capitolato tecnico di prova molto stressante per testare i prodotti e definirli "No Drip". I modelli che appartengono a questa categoria sono molto efficaci nel risolvere il problema e lo fanno secondo specifiche caratteristiche strutturali riassunte nella tabella che segue.

As of today, no standard, internationally recognized "anti-condensation" tests exist. Elica has developed its own high-stress technical test specifications to test its products and classify them as "No Drip". Models in this category are very efficient in resolving this problem, according to some specific structural characteristics, which are summarized in the table below.



	BOXIN NO DRIP	BOXIN DRY	MAJESTIC NO DRIP	RULES
Resistenze elettriche Electrical resistances	X	-	X	-
Griglie inclinate brevettate Patented tilted grids	X	X	X	X
Vano raccolta condensa Condensation collection tray	X	X	X	X
Veletta proteggi-pensile Cabinet-protection Visor	X	X	-	-

ASPIRAZIONE / SUCTION



CONNECTIVITY

Con la crescente diffusione del mondo IoT, è diventata ormai prassi comune governare i propri dispositivi grazie alla connessione wi-fi. Oggi possiamo comandare la nostra cappa tramite l'app Elica dedicata o attraverso vocal control per avviarla o spegnerla, regolarne la potenza aspirante o l'intensità e il colore della luce, semplicemente con un clic o con il supporto dei più diffusi vocal assistant. L'app diventa inoltre un utile strumento per la manutenzione del prodotto, grazie a periodiche notifiche che ne segnalano lo stato, eventuali operazioni di pulizia necessarie o l'esigenza di sostituire i filtri.

With the increasing widespread diffusion of the IoT world, it has become common practice to manage all your devices with a wi-fi connection. We can now control our extraction hood with the dedicated Elica app or through voice control to turn it on or off, adjust the extraction speed or intensity and the colour of the light, simply with a click or the help of the most popular vocal assistants. The app also becomes a useful tool for maintaining the product, thanks to periodic notifications which report on its status, any cleaning operations required or filters that need replacing.



SPECIAL MATERIAL

Nella ricerca di prodotti belli da esibire ma funzionali nell'utilizzo quotidiano, i materiali giocano un ruolo chiave. Possono fare la differenza sia in termini di estetica, diventando protagonisti o scomparendo tra i mobili, che di facilità di manutenzione nel tempo. Fondamentali nel processo di innovazione, sono alla base di un look accattivante e di un'esperienza d'uso appagante. Elica seleziona materiali in cui durevolezza, facilità di pulizia e impatto estetico sono combinati in perfetto equilibrio. L'ampia selezione di finiture disponibili offre la massima libertà di scelta per ogni tipo di ambiente.

In the quest for attractive products to show off but which have a functional, everyday use, materials play a key role. They can make the difference by becoming an attractive signature feature or by disappearing into the background and by being easy to maintain in the long term. They are fundamental in the process of innovation, forming the basis of an attractive look and a fulfilling user experience. Elica selects materials in which sturdiness, easy cleaning and aesthetic impact are combined in a perfect balance. The wide selection of finishes available offers maximum freedom of choice whatever the setting.



BACK ASPIRATION

Si ampliano le possibilità di installazione della tua cappa. Sui modelli dotati di questa funzione, è possibile ruotare il convogliatore e collegare direttamente la cappa con il muro posteriore oppure in altri modelli la particolare architettura del prodotto consente di realizzare l'uscita a muro tramite un curva a 90 gradi del tubo. In questo modo si può contare sulla massima aspirazione, preservando l'estetica originale del prodotto, che non verrà modificata da tubi o camini aggiuntivi a vista.

There are now more ways of installing your extraction hood. On models with this function, it is possible to rotate the conveyor and directly connected the hood with the outlet in the wall behind it or in other models, the special architecture of the product allows the wall outlet to be created with a 90-degree elbow pipe. Thus, you can rely on maximum extraction while preserving the original outward appearance of the product which will not be modified by pipes or additional visible flues.



TOTAL INTEGRATION

Sempre più diffusa nelle cucine di oggi, la tendenza al total look privilegia un design uniforme e lineare. I prodotti si integrano perfettamente nella cucina e nel living, grazie a soluzioni di installazione adattabili ad ogni spazio e a un design minimale, in totale armonia con l'ambiente circostante.

The increasingly more popular "total look" trend, favors a uniform and linear design style for today's modern kitchen. Our products perfectly blend in with the kitchen and living room, thanks to installation solutions that can adapt to any space and minimal design furnishing, in full harmony with their surroundings.



COMFORT SILENCE

Con la diffusa tendenza di progettare la cucina a vista sul living, diventa importante poter contare su cappe che abbiano una grande capacità aspirante e che non siano rumorose, per non risultare invasive nell'ambiente circostante. Grazie alla tecnologia Comfort Silence il livello acustico delle cappe Elica alla massima velocità di aspirazione non disturba né interferisce con la conversazione tra i presenti.

With the widespread tendency to design open-plan kitchens joined to the living room, it has become important to be able to rely on hoods with a greater extraction capability which are quieter, so they do not intrude on the surroundings. Thanks to Comfort Silence, the sound level of Elica extraction hoods at maximum extraction speed does not disturb or interfere with the conversation of those present.



SUPER EASY INSTALLATION

Con l'esclusivo sistema Elica, il montaggio avviene in totale sicurezza e in pochissimi passaggi, salvaguardando l'estetica del prodotto e dello spazio in cui viene posizionato. Dopo il bloccaggio automatico del prodotto in sede, è possibile regolare al millimetro i punti di fissaggio, preservando il design lineare della cucina e assicurando la perfetta integrazione della cappa nell'ambiente. Una soluzione, facile, robusta e sicura.

With the exclusive Elica system, installation can be done in total safety in just a few steps, safeguarding the look of the product and the space in which it is positioned. After the hood is automatically locked in position, the fastening points can be finely adjusted to preserve the linear design of the kitchen and ensure perfect integration of the hood in the room. A simple, hard-wearing and safe solution.



LONG LIFE FILTER

Per semplificare le attività di manutenzione e ridurre l'impatto ambientale, Elica propone il filtro odore Long Life Filter che può essere lavato e rigenerato, prolungando la sua durata fino a 3 anni rispetto ai filtri tradizionali per cui è prevista la sostituzione ogni 3/6 mesi.

To simplify maintenance operations and reduce environmental impact, Elica offers its Long Life Odor Filter, that can be washed and regenerated, making it last up to 3 years in comparison to traditional filters, which should be replaced every 3/6 months.



LONG LIFE FILTER ++

I filtri Long Life Filter ++ sono stati studiati da Elica per raggiungere le massime prestazioni e garantire una efficienza di filtraggio odori di gran lunga superiore alla media. Per semplificare le attività di manutenzione e ridurre l'impatto ambientale, questi filtri odori hanno la capacità di rigenerarsi e di durare dai 3 ai 5 anni, evitando così frequenti sostituzioni e sprechi.

Long-Life Filters ++ have been developed by Elica to reach maximum performance levels and guarantee odor filtering efficiency, which is much higher than average. In order to simplify maintenance operations and reduce environmental impact, these anti-odor filters can be regenerated, lasting up to 3 to 5 years, thus avoiding frequent replacements and waste.



DELAY SWITCH OFF

Una funzione timer intelligente che ti permette di impostare lo spegnimento automatico del prodotto dopo un tempo predeterminato. Lo spegnimento ritardato può essere utilizzato al fine di lasciare la cappa in funzione anche dopo la cottura, così da eliminare completamente gli odori persistenti e l'umidità residua.

A smart timer feature allows you to set the automatic switch-off of the product after a predetermined time. Delayed shutdown may be used in order to leave the hood on even after cooking, so to fully remove stubborn odors and residual humidity.

ASPIRAZIONE / SUCTION



PERIMETER ASPIRATION

L'aspirazione della cappa è efficientemente distribuita su tutto il perimetro del prodotto. La parte aspirante è totalmente nascosta da un pannello e l'estetica risulta più elegante, moderna e pulita.

Hood extraction is efficiently distributed all along the perimeter of the appliance. The extraction zone is completely hidden by a panel, giving it a more elegant, modern, cleaner look.



DIM LIGHT

La luce in cucina, così come in ogni ambiente domestico, rappresenta una leva progettuale importante per vivere al meglio i propri spazi. Modulare la giusta intensità diventa fondamentale per ricreare l'atmosfera desiderata. Ecco perché Elica ha progettato la funzione Dim Light, che permette di regolare la potenza luminosa della propria cappa attraverso un semplice comando. Luce al massimo per avere la migliore visibilità sul piano da lavoro, o soffusa per goderci momenti di relax.

The light in the kitchen, as in any room, is a key design feature for improving the home living experience. Achieving the right intensity becomes fundamental in creating the desired atmosphere. Which is why Elica has designed the Dim light function which allows you to adjust the intensity of your extraction hood light with a simple control. Maximum light for the best visibility on the worktop or dimmed when relaxing.



TUNE WHITE

Avere toni di illuminazione differenti può essere molto utile, a seconda dei momenti e delle attività svolte in casa. Una luce fredda è ottimale per cucinare, ma una luce calda può opportunamente ricreare un mood più rilassato. Con il Tune White è possibile regolare il colore dei led, dal bianco caldo al bianco freddo, allineando il colore delle lampade della cappa con quelle presenti nell'ambiente, per un'atmosfera uniforme in tutta la stanza.

Selecting various lighting tones can be very useful, based on certain moments and household activities. A cool light is best for cooking, but a warm light creates a more relaxing mood. With the Tune White feature, it is possible to adjust the LED colors, from warm white, to cool white, matching the hood lights to those of the room, for a uniform atmosphere throughout the space.

ASPIRAZIONE / SUCTION



EASY TO MAINTAIN

Mantenere la propria cappa pulita non solo garantisce la massima igiene in cucina, ma assicura una vita più lunga al prodotto. I modelli Elica sono progettati con materiali e finiture che rendono le operazioni di manutenzione immediate. Tutte le componenti, come i filtri grassi e odori, sono facilmente raggiungibili e rimovibili, per poterli lavare o sostituire velocemente.

Keeping your hood clean not only ensures maximum hygiene in the kitchen but also long life for the product. The Elica models are designed with materials and finishes for instant maintenance operations. All the components, such as the grease and odour filters, can be easily accessed and removed so they can be washed or rapidly replaced.



AIRMATIC - NIKOLATESLA

Oggi grazie a Airmatic il tuo piano aspirante è completamente automatico. Il suo sensore intelligente è in grado di distinguere la qualità dei fumi e i tipi di cottura e di abbinare queste informazioni al numero e alla potenza delle zone a induzione utilizzate. Anche quando la cottura è terminata il sistema si adatta autonomamente diminuendo gradualmente l'aspirazione e eliminando i vapori, gli odori e l'umidità residua. Questa tecnologia avanzata rappresenta un'eccellenza nel mondo dei piani cottura aspiranti e consente di ottenere il miglior equilibrio tra silenzio, potenza ed efficienza energetica.

Airmatic makes your extractor hob fully automatic. Its smart sensor is able to distinguish fume quality and type of cooking, and based on this information, adjusts the number and power of the induction zones used. Even when cooking is finished, the system automatically adapts, gradually lowering extraction and eliminating any residual vapors, odors and humidity. This advanced technology represents the highest level in the extractor hob market, thus allowing for the best balance between silence, power and energy savings.



AIRMATIC

La funzione Airmatic si prende cura dell'aria del tuo ambiente domestico per tutto il giorno, automaticamente. Il sensore riconosce la qualità dell'aria anche oltre il momento della cottura, rilevando odori e vapori sgradevoli ma anche inquinanti come solventi di pulizia, fumo di sigaretta e tutti i composti organici volatili (VOC). Con tali informazioni, la cappa regola automaticamente il flusso aspirante e quando la qualità dell'aria è tornata ad un livello ottimale, si spegne da sola evitando sprechi energetici. Questa tecnologia permette di ottenere il miglior equilibrio tra semplicità di utilizzo, efficienza energetica e rumorosità.

The Airmatic feature automatically treats your indoor air all day long. The sensor identifies air quality even after cooking, detecting unpleasant odors and vapors, as well as pollutants such as cleaning solvents, cigarette smoke and all volatile organic compounds (VOC). Using such information, the hood automatically regulates the extraction flow and once air quality has returned to an ideal level, it automatically switches off, thus avoiding any energy waste. This technology allows for the best balance between easy usability, energy savings and low noise levels.



AUTOCAPTURE

Con Autocapture non dovrai preoccuparti di regolare l'aspirazione in base alle cotture avviate, ma sarà la cappa stessa a identificare le zone cottura attive e impostare di conseguenza la potenza, tenendo in considerazione il miglior equilibrio tra silenzio, potenza ed efficienza energetica. E a cottura ultimata, il sistema diminuisce gradualmente la velocità, in modo da eliminare i vapori, gli odori e l'umidità residua. Il piano cottura aspirante diventa ancora più funzionale e pratico, per cotture perfette e aspirazione ottimale.

With Autocapture you never have to worry about adjusting extraction based on the food you are cooking, as the hood identifies active cooking zones and sets the proper power level, ensuring the best balance between silence, power and energy savings. Once cooking has ended, the system gradually lowers speed, in order to remove vapors, odors and residual humidity. The extractor hob becomes even more functional and practical, for perfect cooking and top-level extraction.

ASPIRAZIONE / SUCTION



MAINTENANCE ALARM

I prodotti dotati di questa funzione sono equipaggiati con un indicatore luminoso che fornisce un alert quando i filtri grassi e i filtri odori stanno per raggiungere la loro massima saturazione. Così saprai sempre quando devi lavarli o sostituirli e potrai mantenere il tuo prodotto pulito e funzionale nel tempo.

Products equipped with this feature have an indicator light that alerts the user when grease and odor filters are about to reach maximum saturation. Therefore, it's easy to always know when it's time to wash or replace them, in order to keep the appliance clean and operating properly over time.



CABINET PROTECTION

È la risposta estetica e funzionale di Elica che garantisce una protezione totale del pensile dai vapori di cottura. Il design del prodotto prevede protezioni laterali e una ergonomica visiera frontale, per scongiurare qualsiasi potenziale danno di usura del pensile e preservando nel tempo la bellezza della tua cucina.

Elica's aesthetic and functional solution that guarantees total protection of the cabinets from cooking vapors. The product is designed with side protections and an ergonomic front visor, to avoid any potential damage to the cabinets and to preserve the beauty of your kitchen over time.



NO DRIP SYSTEM

No Drip System affronta il problema del vapore alla radice. E' stato ideato e progettato per evitare lo sgocciolamento generato dall'aria calda che entra a contatto con una superficie fredda, specialmente quando si cucina su un piano a induzione. I prodotti equipaggiati con questo sistema prevedono soluzioni tecniche e progettuali in grado di ridurre la formazione di condensa e evitarne l'eventuale ricaduta residuale sul piano cottura e sulle pietanze in preparazione.

The No Drip System tackles the problem of vapor from the start. It was conceived and developed to avoid dripping caused by hot air coming into contact with cold surfaces, especially when cooking on an induction hob. Products equipped with this system provide technical and design solutions capable of reducing the formation of condensation, thus avoiding residual dripping onto the hob or food.



PURIFICAZIONE DELL'ARIA / AIR PURIFICATION

ELICA AIR PURE



MULTIFUNCTION

Ikona Maxxi Pure incorpora in un unico prodotto una cappa e un purificatore d'aria. Il prodotto è stato sapientemente progettato per separare il modulo cappa dal purificatore d'aria senza alcun compromesso in termini di prestazioni e fruibilità e per farli funzionare il modo efficace ed indipendente. Un prodotto "2 in 1" progettato per migliorare la qualità dell'aria, senza la necessità di dispositivi aggiuntivi o sistemi di monitoraggio complessi, spesso ingombranti e antiestetici.

Ikona Maxxi Pure incorporates a hood and air purifier in a single product. The product has been cleverly designed to separate the hood module from the air purifier without compromising on performance and usability, and to make them work efficiently and independently. A "2 in 1" product designed to improve the air quality without the need for additional devices or complex monitoring systems, often invasive and disagreeable.



PURE SILENCE

La purificazione dell'aria è estremamente discreta, in modalità Silent il livello sonoro di 37 dBA è impercettibile, paragonabile al livello sonoro di una biblioteca. Il sistema Elica funziona senza alcun inquinamento acustico, creando un ambiente confortevole nella tua cucina-living.

The air purification is extremely discreet, in Silent mode the sound level of 37 dBA is imperceptible, comparable to the sound level of a library. The Elica system works without any noise pollution, creating a comfortable environment in your kitchen-living area.



COMBO PURE FILTER

Il purificatore d'aria, dotato di una speciale combinazione di HEPA e filtro al carbone, cattura particelle fino a 1 micron, liberando il tuo spazio da odori, allergeni come polvere, peli di animali, pollini, muffe, inquinanti prodotti da prodotti per la pulizia della casa, pitture e rivestimenti.

The air purifier, fitted with a special combined HEPA and carbon filter, captures particles as small as 1 micron, freeing the space of unpleasant odours, allergens such as dust, animal hair, pollen, mould, pollutants produced by household cleaning agents, paints and coverings.

COTTURA / COOKING



STOP & GO

Capita a volte che ci si debba allontanare improvvisamente dalla cucina proprio nel bel mezzo della preparazione di una ricetta, interrompendo la cottura dei cibi. Stop&Go permette di sospendere, con un solo gesto, tutte le funzioni attive sul piano per poi riavviarle ripristinando le impostazioni precedenti tramite la semplice pressione di un tasto, unendo sicurezza, risultato di cottura e gestione del multitasking.

At times, we must suddenly leave the kitchen in the middle of our recipe and stop cooking. The Stop&Go feature lets us pause all of the features in use on the hob, to later restore them back to what was previously set, by just pressing a button. Thus combining safety, great cooking results and multitasking magamenet.



TIMER

Dimenticati del tempo di cottura dei piatti attivando il timer. Basterà impostare i minuti e far partire il countdown, al termine si spegnerà automaticamente la zona cottura e si attiverà un segnale acustico. È possibile impostare timer indipendenti su più zone contemporaneamente tramite il telecomando touch.

Forget about cooking times by turning on the timer. Just set the minutes and start the countdown. At the end, the cooking area will be automatically switched off and a beeper will sound. You can set independent timers on more than one area at the same time with the touch remote control.



POWER LIMITATION

Con Power Limitation imposti, in fase di installazione, il limite di potenza massima assorbita dal prodotto, assicurandoti così di non superare mai la soglia preimpostata. Cucinare al meglio senza interruzioni e in totale sicurezza.

If Power Limitation is set during installation, the maximum power absorbed by the product is limited, thus ensuring that you never exceed the pre-set limit. So you can cook efficiently with no interruptions in total safety.



CHILD LOCK

Per chi ha bambini in casa la funzione Child Lock è preziosa per evitare accensioni accidentali delle zone cottura o dell'aspirazione. La funzione può essere attivata a prodotto acceso, ma con le aree cottura e l'aspirazione spente.

If you have children in your home, the Child Lock function is invaluable for ensuring the cooking or extraction areas are not accidentally switched on. The function can be enabled when the product is switched on but the cooking areas and extraction are switched off.



DUAL ZONE

Il piano è dotato di due zone concentriche utilizzabili in modo indipendente tra di loro. Sia che utilizzi una piccola pentola o un grande tegame, il tuo piano cottura risulterà perfetto in ogni caso.

The hob is equipped with two concentric zones, which can be used separately. Regardless of whether you use a small pot or large pan, your hob will always be at its best.



POT SELF-DETECTION

Il piano è dotato di una tecnologia che rileva automaticamente la presenza di pentole sulle zone cottura attivando istantaneamente il comando corrispondente in modo che l'utente debba scegliere solo la potenza da impostare. Grazie a questa funzione il prodotto è efficiente e sicuro poiché si attiva solo in presenza di pentole correttamente posizionate.

The hob is equipped with special technology that automatically detects the presence of cookware on the cooking zones. Once detected, the corresponding controls will light up on the interface, thus letting the user set the power level. Thanks to this feature, the appliance is efficient and safe, activating only in the presence of correctly positioned cookware.

COTTURA / COOKING



BRIDGE ZONE

Quando si cucina utilizzando pentole allungate o di grande dimensioni, il rischio è che si disperda progressivamente il calore sulla superficie della teglia, dal centro verso l'esterno. La funzione Bridge Zone risolve il problema, collegando due aree di cottura in un'unica zona dalle dimensioni più grandi. Stesso livello di potenza, temperatura uniforme e costante per la migliore resa dei tuoi piatti.

When you cook using longer or large pans, there is a risk that the heat is progressively dispersed on the surface of the pan from the centre outwards. The Bridge Zone function solves the problem by joining two cooking areas into one single larger area. With the same power, uniform and constant temperature for the best result of your dishes.



EXTRALARGE ZONE

Che tu voglia cucinare per tutta la famiglia o per gli amici, la Extralarge Zone fa al caso tuo. Potrai comodamente usare grandi pentole (fino a 30 cm di diametro) oppure cuocere pietanze in modo più rapido grazie alla sua potenza superiore rispetto ad un comune piano cottura ad induzione presente sul mercato.

Whether you are cooking for your entire family or some friends, our Extralarge Zone is just what you need. Cook using large pots and pans (up to 30 cm in diameter), or prepare special dishes faster, thanks to higher power levels in comparison to the average induction hob on the market.



MULTI FLEXI SPACE

Tante pentole grandi sul fuoco insieme? Con il sistema Multi Flexi Space puoi contare su un maggiore spazio in lunghezza e in larghezza per i tuoi tegami. Puoi far scivolare le padelle da un fuoco all'altro senza sollevarle, grazie alle griglie a croce chiusa che ricreano una superficie piatta e continua. Un pratico piano di appoggio in ghisa consente di avere sempre a portata di mano tutto quello di cui hai bisogno.

Lots of large pans on the stove together? With the Multi Flex Space system, you have more space available both in length and width when using large pots. You can slide the pans from one ring to another without lifting them thanks to the closed cross grids which create a flat, continuous surface. A practical cast iron worktop ensures that everything you need is always at hand.

COTTURA / COOKING



MELTING MODE

La funzione Melting Mode è la soluzione ideale per le preparazioni delicate, come sciogliere il burro o il cioccolato, senza comprometterne le caratteristiche sensoriali. La temperatura è mantenuta molto bassa (sotto i 50°) al fine di assicurare il completo scioglimento degli ingredienti senza bisogno di mescolare continuamente e senza rischiare che si attacchino al fondo della pentola.

The Melting Mode feature is the ideal solution for more delicate cooking, such as melting butter or chocolate, without ruining their texture or taste. The temperature is kept very low (below 50°) to assure that the ingredients fully melt, without the need to continuously mix them, and with no risk of ingredients sticking to the bottom of the pot.



WARMING MODE

La funzione è stata ideata per preparazioni a cottura lenta, è ideale per riscaldare pietanze liquide come latte e brodi, ma anche creme e salse, senza doversi preoccupare del loro surriscaldamento. Inoltre, con Warming Mode puoi tenere in caldo il cibo già pronto mentre le altre preparazioni sono ancora in corso.

This feature was designed for low temperature cooking, ideal for heating liquids such as milk and broth, as well as creams and sauces without worrying about them over-heating. Furthermore, Warming Mode keeps prepared food warm, while other foods are still cooking.



SIMMERING MODE

La funzione permette al cibo di sobbollire per periodi prolungati, scongiurando l'ebollizione eccessiva e l'accidentale fuoriuscita di liquidi dalla pentola. Allo stesso tempo, evita l'indurimento della pietanza o possibili bruciature sul fondo della pentola, tipiche di preparazioni come riso, zuppe e verdure bollite.

This particular feature controls the power level of the cooking zone, allowing foods to simmer for long periods of time, preventing over-boiling and accidental liquid over-flow. At the same time, it prevents the hardening of foods or possible burning at the bottom of the pot, which is typical when preparing rice, soups and boiled vegetables.



COTTURA / COOKING



FAST BOILING

Questa funzione è perfetta per cotture che richiedono una maggiore rapidità di preparazione. Con un unico gesto si imposta la zona cottura alla massima velocità per 10 minuti, portando ad ebollizione il contenuto della pentola il 30% più velocemente rispetto ad un comune piano ad induzione presente sul mercato.

This feature is perfect for foods that require faster cooking. Just one touch sets the cooking zone at maximum speed, for 10 minutes, bringing the contents of the pot to a boil 30% faster, in comparison to common induction hobs available on the market.



TASTY FRY

Che si cucini una o più porzioni, il piano assicura sempre pietanze fritte di alta qualità. Il potente sistema a induzione permette all'olio di raggiungere la temperatura ideale per una frittura perfetta (180°) in metà del tempo rispetto ad un piano cottura tradizionale. In questo modo, le preparazioni assorbono meno olio, garantendo piatti più sani e la possibilità di cuocere più porzioni in minor tempo.

Whether cooking one or more portions, the hob always assures great tasting fried foods. The powerful induction system allows oil to reach an ideal frying temperature (180°) in half the time, in comparison to traditional hobs. In this way, food absorbs less oil, resulting in healthier dishes and the possibility of cooking more portions in less time.



RECALL

In caso di spegnimento accidentale del piano la funzione Recall, se attivata entro 6 secondi, permette con un gesto il ripristino dei settaggi impostati prima dell'interruzione sia di tutte le zone cottura che dell'aspirazione.

If the hob is accidentally switched off, the Recall feature is activated within 6 seconds: just one touch is all it takes to reset all of the previously set features, on all cooking zones and the extraction system.

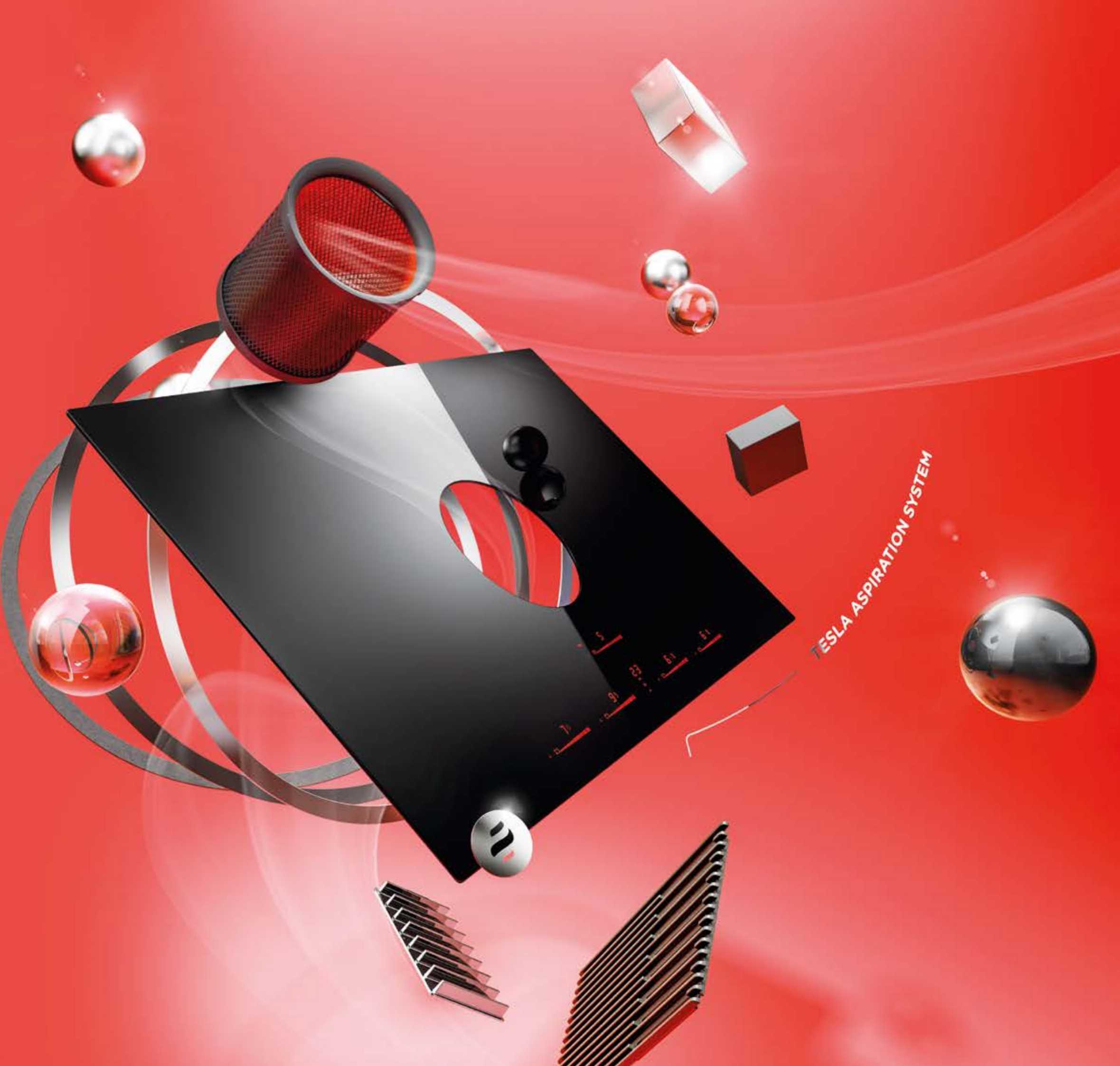

NIKOLATESLA

Cottura e aspirazione, solidità e stile diventano gli elementi complementari che danno vita a un prodotto unico. La prospettiva scomposta mette in luce i ricercati materiali caratterizzanti la gamma NikolaTesla: le griglie in ghisa e il vetro nero, accostati in un design ricercato e lineare. Il risultato è un'unica visione d'insieme da cui nasce un prodotto dove tecnologia e innovazione, design ed eleganza si esprimono in un perfetto equilibrio. L'intuitivo cambio di prospettiva porta l'aspirazione in basso, conferendo al prodotto una componente innovativa di grande valore.

Cooking and extraction, dependability and style are the added elements that create a unique product. The broken-up view highlights the refined materials that characterise the NikolaTesla range: the cast iron grilles and black glass, combined in a refined and linear design. The result is a unique overall vision for a product where technology and innovation, design and elegance are showcased in perfect harmony. The intuitive change of perspective features downward extraction, resulting in a highly-innovative product.

FUNZIONAMENTO E PRINCIPALI PLUS

OPERATION AND MAIN ADVANTAGES

La qualità dell'aria è da sempre alla base dell'offerta di elica, che ha portato anche nei piani cottura le migliori tecnologie per una aspirazione dal basso intelligente e performante di fumi e odori.

MIGLIORE VELOCITÀ DI ASPIRAZIONE

BEST EXTRACTION SPEED

Tutti i modelli NikolaTesla hanno una velocità di aspirazione di 5,1 m/s, e riescono a catturare tutti i fumi e gli odori prima che salgano verso l'alto. Questa caratteristica li rende prodotti unici nel loro genere per efficacia e prestazioni.

All the NikolaTesla models provide a very powerful extraction speed of 5.1 m/s. They can capture all the fumes and odours before they start to rise. This feature makes these products unique in terms of efficiency and performance.



SENSORI INTELLIGENTI E NON CI PENSI PIÙ

SMART SENSORS AND THAT'S ALL YOU NEED TO KNOW

L'innovativa funzione Airmatic prevede l'utilizzo di sensori intelligenti, che permettono di distinguere la quantità e la qualità dei fumi prodotti e impostare la potenza di aspirazione più indicata.

The innovative Airmatic function involves the use of smart sensors which are able to detect the quantity and quality of the fumes produced and to set the most suitable extraction power accordingly.

Quality of air has always been key to Elica's products, incorporating the very best technology in hobs for intelligent, high-performance, downdraft extraction of fumes and of odours.



PIÙ SPAZIO PER I TUOI CASSETTI

MORE SPACE FOR DRAWERS

Il design del prodotto è stato studiato per ottimizzare gli spazi interni del cabinet. La tubazione posteriore mobile e posizionabile a ridosso dello schienale del mobile, consente l'utilizzo di cassetti più profondi e spaziosi. Il risultato è una maggiore superficie libera dall'ingombro del piano, da poter sfruttare per la conservazione di cibi o utensili da cucina.

The product design has been studied to optimise the internal spaces of the cabinet. The adjustable and positionable rear pipe, which sits flush to the back of the cabinet, makes room for deeper and more spacious drawers. The result is greater a surface area, unobstructed by the worktop, which can be used to store food or kitchen utensils.

AUTOREGOLAZIONE DELL'ASPIRAZIONE

SELF-ADJUSTING EXTRACTION

Con Autocapture possiamo rimanere concentrati solo sulla nostra ricetta: sarà la cappa ad autoregolarsi in base al numero e alla potenza delle zone cottura impegnate.

With Autocapture, you can concentrate on your recipe and leave the hood to automatically adjust based on the number and power of the hobs being used.



PULIZIA FACILE E VELOCE

FAST AND EASY TO CLEAN

La superficie liscia e continua di NikolaTesla è uno degli elementi innovativi della nuova generazione di piani aspiranti Elica. Il vetro ceramico, privo di interruzioni, si rivela un dettaglio di design efficace anche nel rendere veloce la pulizia.

The smooth, seamless surface of NikolaTesla is one of the innovative features of the new generation of Elica extraction hobs. The seamless ceramic glass is an efficient design detail that also makes short work of cleaning.

MANUTENZIONE PRATICA

PRACTICAL MAINTENANCE

La bellezza si coniuga alla praticità anche nelle operazioni di manutenzione: il sistema brevettato da Elica permette la rimozione dei filtri dall'alto e, grazie all'apertura nel vetro che si mimetizza con l'estetica, si può lavare in totale sicurezza il vano interno.

Beauty is combined with practicality when it comes to maintenance as well. The system, patented by Elica, allows the filters to be removed from above while the internal compartment can be washed in total safety, thanks to the opening in the glass that blends in with the aesthetics.



INTERFACCIA INTUITIVA E USER FRIENDLY

INTUITIVE AND USER-FRIENDLY INTERFACE

Per vivere ogni giorno il piacere di cucinare, i piani aspiranti Elica sono dotati di un'interfaccia semplice e intuitiva. Il pannello comandi touch control permette di controllare separatamente zone cottura e cappa e, in modalità standby, diventa totalmente invisibile. Regolare la cottura non è stato mai così facile e confortevole.

Elica extractor hobs feature a simple and intuitive interface to allow you to enjoy the pleasure of cooking every day. The touch control panel allows the cooking areas and hood to be controlled separately and, in standby mode, it becomes totally invisible. Controlling cooking has never been so easy and convenient.



MIGLIORE CAPACITÀ DI FILTRAGGIO ODORI

IMPROVED ODOUR FILTERING CAPABILITY

Ecco perché la gamma NikolaTesla, nella versione filtrante, prevede un filtro ad alta capacità di depurazione degli odori, in grado di raggiungere soglie di filtraggio maggiori dell'80% contro una media del mercato del 60%. E per garantire la massima facilità di manutenzione, è rigenerabile fino a 3 anni.

This is why the NikolaTesla range, in the filtering version, features a filter with a high odour purification capacity, capable of reaching filtering thresholds over 80% compared to a market average of 60%. And to guarantee extremely easy maintenance, the filter can be regenerated for up to 3 years.



NIKOLATESLA UNPLUGGED

DESIGN FABRIZIO CRISÀ



NIKOLATESLA UNPLUGGED

DESIGN FABRIZIO CRISÀ



NIKOLATESLA UNPLUGGED

DESIGN FABRIZIO CRISÀ



90x53x21 cm
80,7x49,2 cm (cut)
Aspirante/Filtrante Duct-out/Filtering
Vetro nero, Vetro nero + acciaio inox
Black glass, Black glass + stainless steel

Il piano aspirante con manopole coniuga risultati di cottura assicurati e facilità di interazione. Le manopole ergonomiche permettono di controllare le varie zone di cottura e di estrazione in modo semplice e intuitivo. I livelli di potenza impostati sono comodamente monitorabili grazie agli indicatori luminosi di colore rosso. Il profilo in silicone separa la zona di cottura da quella dei comandi evitando eventuali urti di pentole e padelle e facilitando le operazioni di pulizia.

The extractor hob with knobs that blends guaranteed cooking results and user-friendliness. The ergonomic knobs control the various cooking and extraction zones, in a simple and intuitive manner. The set power levels are easily monitored, thanks to red indicator lights. The silicone profile separates the cooking zone from that of the controls, thus avoiding damage from cookware and making cleaning easier.

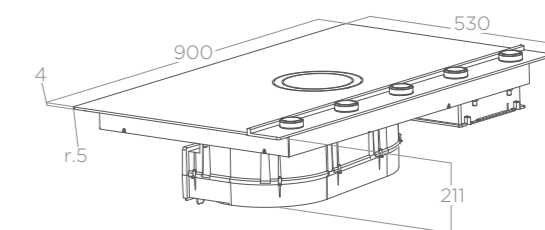

ASPIRANTE



FILTRANTE

	ASPIRANTE DUCT-OUT	FILTRANTE FILTERING
Comandi Controls	Rotativo elettronico 9V+I	Rotativo elettronico 9V+I
Controls	9S+B Electronic rotative	9S+B Electronic rotative
Portata intensiva Booster airflow	630 m ³ /h	550 m ³ /h
Velocità di aspirazione Suction speed	5,1 m/s	5,1 m/s
Livello sonoro min-max Noise level min-max	33 - 66 db(A)	39 - 72 db(A)
Assorbimento totale Total absorption	175 W	175 W

Filtro grassi alluminio incluso Grease aluminium Filter included
Filtro in ceramica anti-odori rigenerabile HP incluso (*)
HP regenerable anti-odor ceramic filter included (*)

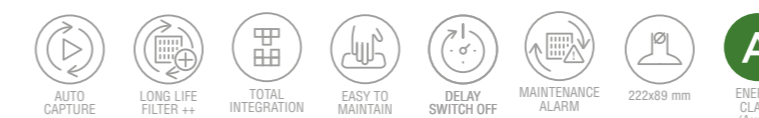

ACCESSORI ACCESSORIES	
Filtro in ceramica anti-odori rigenerabile HP HP regenerable anti-odor ceramic filter	KIT0120952A
Kit NIKOLATESLA filtrante per base profondità > 70 cm NIKOLATESLA filtering kit for base depth >70 cm	KIT0140820

(*) Modello non soggetto a certificazione energetica obbligatoria.
(*) Model not subject to compulsory energy certification.

	COTTURA COOKING
Comandi Controls	Rotativo elettronico 9P+I 9P+B Electronic rotative
Assorbimento Absorption	7,2 KW
Power limitation	4,5 kW
Voltaggio Voltage	220 - 240 V
Zone cottura Cooking zones (Misura-Potenza Size-Power)	1 220x184 mm - 2,1/3,7 kW 2 220x184 mm - 2,1/3,7 kW 3 220x184 mm - 2,1/3,7 kW 4 220x184 mm - 2,1/3,7 kW
Zone Bridge Bridge zone	2

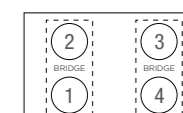

MODELLI MODELS	
NIKOLATESLA UNPLUGGED BL/A/90	PRF0184546
NIKOLATESLA UNPLUGGED BL/F/90 (*)	PRF0184019
NIKOLATESLA UNPLUGGED BLIX/A/90	PRF0184547
NIKOLATESLA UNPLUGGED BLIX/F/90 (*)	PRF0184545

Grazie alla soluzione brevettata da Elica i filtri odori ceramici si estraggono facilmente dall'alto con l'ausilio di un pratico nastro.
Thanks to our Elica patented solution, ceramic odor filters are easily removable from the top, with the help of a handy ribbon



NIKOLATESLA ONE HP

DESIGN FABRIZIO CRISÀ



NIKOLATESLA ONE HP

DESIGN FABRIZIO CRISÀ

83x51,5x21 cm
80,7x49,2 cm (cut)
Aspirante/Filtrante Duct-out/Filtering
Vetro nero
Black glass



Il prodotto, vincitore del XXV Compasso D'oro ADI, combina la tecnologia più avanzata per la cattura di vapori ed odori dal basso all'eccellenza del design distintivo Elica. L'interfaccia del prodotto Direct Slider permette di azionare le varie zone di cottura e aspirazione in modo semplice ed intuitivo.

The product, winner of the 25th ADI Compasso d'Oro award, combines cutting-edge downdraft technology, to capture vapours and odours, with Elica's signature state-of-the-art design. The Direct Slider interface allows the various cooking and extraction areas to be controlled simply and intuitively.

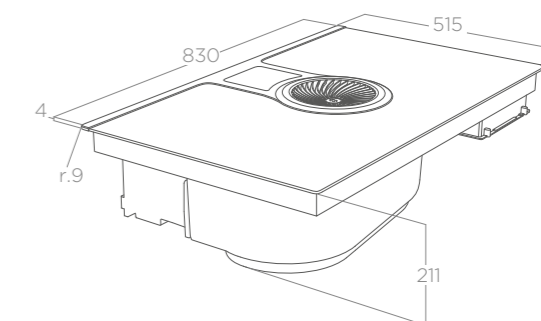

	ASPIRAZIONE ASPIRATION	
	ASPIRANTE DUCT-OUT	FILTRANTE FILTERING
Comandi Controls	Touch Control Slider 9V+I	Touch Control Slider 9V+I
	9S+B Slider touch control	9S+B Slider touch control
Portata intensiva Booster airflow	640 m ³ /h	545 m ³ /h
Velocità di aspirazione Suction speed	5,1 m/s	5,1 m/s
Livello sonoro min-max Noise level min-max	34 - 66 db(A)	40 - 72 db(A)
Assorbimento totale Total absorption	175 W	175 W

Filtro grassi alluminio incluso Grease aluminium Filter included
Filtro in ceramica anti-odori rigenerabile HP incluso (*)
HP regenerable anti-odor ceramic filter included (*)

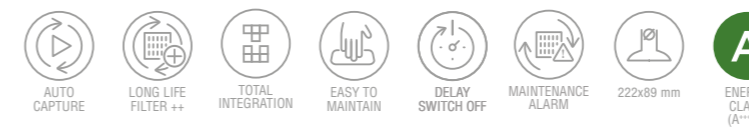

ACCESSORI ACCESSORIES	
Filtro in ceramica anti-odori rigenerabile HP HP regenerable anti-odor ceramic filter	KIT0120952A
Kit Nikolatesla filtrante per base profondità > 70 cm Nikolatesla filtering kit for base depth >70 cm	KIT0140820

(*) Modello non soggetto a certificazione energetica obbligatoria.
(*) Model not subject to compulsory energy certification.

COTTURA COOKING	
Comandi Controls	Touch control direct slider 9P+I 9P+B Touch control direct slider
Assorbimento Absorption	7,2 KW
Power limitation	4,5 kW
Voltaggio Voltage	220 - 240 V
Zone cottura Cooking zones (Misura-Potenza Size-Power)	1 220x184 mm - 2,1/3,7 kW 2 220x184 mm - 2,1/3,7 kW 3 220x184 mm - 2,1/3,7 kW 4 220x184 mm - 2,1/3,7 kW
Zone Bridge Bridge zone	2

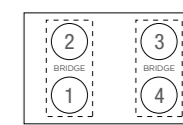

FUNZIONI FUNCTIONS	
MELTING MODE	WARMING MODE
SIMMERING MODE	FAST-BOILING
TASTY FRY	BRIDGE ZONES
POT SELF-DETECTION	STOP & GO
RECALL	CHILD LOCK
TIMER	

MODELLI MODELS	
NIKOLATESLA HP BL/A/83	PRF0120975B
NIKOLATESLA HP BL/F/83 (*)	PRF0120976B

PATENTED Grazie alla soluzione brevettata da Elica i filtri odori ceramici si estraiono facilmente dall'alto con l'ausilio di un pratico nastro.
Thanks to our Elica patented solution, ceramic odor filters are easily removable from the top, with the help of a handy ribbon





NIKOLATESLA ONE

DESIGN FABRIZIO CRISÀ

83x51,5x21 cm
80,7x49,2 cm (cut)
Aspirante/Filtrante Duct-out/Filtering
Vetro nero
Black glass



 Il prodotto, vincitore del XXV Compasso D'oro ADI, combina la tecnologia più avanzata per la cattura di vapori ed odori dal basso all'eccellenza del design distintivo Elica.
The product, winner of the 25th ADI Compasso d'Oro award, combines cutting-edge downdraft technology, to capture vapours and odours, with Elica's signature state-of-the-art design.

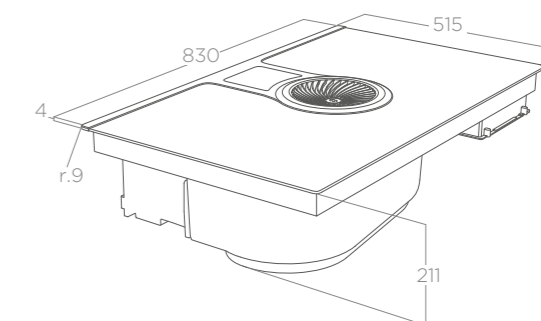

	ASPIRAZIONE ASPIRATION	
	ASPIRANTE DUCT-OUT	FILTRANTE FILTERING
Comandi Controls	Touch control 9V+I	Touch control 9V+I
Controls	9S+B Touch control	9S+B Touch control
Portata intensiva Booster airflow	640 m ³ /h	545 m ³ /h
Velocità di aspirazione Suction speed	5,1 m/s	5,1 m/s
Livello sonoro min-max Noise level min-max	34 - 66 db(A)	40 - 72 db(A)
Assorbimento totale Total absorption	175 W	175 W

Filtro grassi alluminio incluso Grease aluminium Filter included
Filtro in ceramica anti-odori rigenerabile HP incluso (*)
HP regenerable anti-odor ceramic filter included (*)

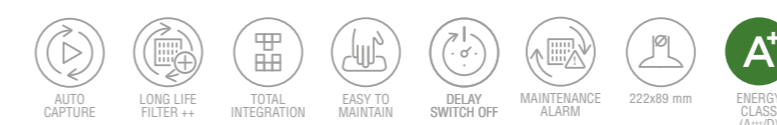

	ACCESSORI ACCESSORIES	
Filtro in ceramica anti-odori rigenerabile HP HP regenerable anti-odor ceramic filter	KIT0120952A	
Kit NikolaTesla filtrante per base profondità > 70 cm NikolaTesla filtering kit for base depth >70 cm	KIT0140820	

	COTTURA COOKING	
Comandi Controls	Touch control 9P+I 9P+B Touch control	
Assorbimento Absorption	7,2 KW	
Power limitation	3,1 - 4,5 kW	
Voltaggio Voltage	220 - 240 V	
Zone cottura Cooking zones (Misura-Potenza Size-Power)	1 210x191 mm - 1,6/1,85 kW 2 210x191 mm - 2,1/3 kW 3 Ø200 mm - 2,3/3 kW 4 Ø160 mm - 1,2/1,4 kW	
Zone Bridge Bridge zone	1 sinistra left	

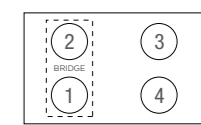

FUNZIONI FUNCTIONS	
	WARMING MODE
	BRIDGE ZONES
	CHILD LOCK
	TIMER

MODELLI MODELS	
NIKOLATESLA BL/A/83	PRF0120977A
NIKOLATESLA BL/F/83 (*)	PRF0120978A

 Grazie alla soluzione brevettata da Elica i filtri odori ceramici si estraggono facilmente dall'alto con l'ausilio di un pratico nastro.
Thanks to our Elica patented solution, ceramic odor filters are easily removable from the top, with the help of a handy ribbon

(*) Modello non soggetto a certificazione energetica obbligatoria.
(*) Model not subject to compulsory energy certification.





NIKOLATESLA SWITCH GLOW

DESIGN FABRIZIO CRISÀ



NIKOLATESLA SWITCH GLOW

DESIGN FABRIZIO CRISÀ



83x51,5x21 cm
80,7x49,2 cm (cut)
Aspirante/Filtrante Duct-out/Filtering
Vetro nero
Black glass

L'elemento estetico centrale nasconde il cuore aspirante del prodotto che può essere attivato con un semplice gesto anche in modalità completamente automatica, possibile grazie ai sensori intelligenti di cui il prodotto è dotato. L'interfaccia del prodotto permette di azionare, in modo semplice e intuitivo, ogni singola zona di cottura e aspirazione grazie allo slider dedicato dalla nuova retroilluminazione bianca. The central aesthetic element hides the extraction core of the product, which is activated with just one touch, and even automatically, thanks to the smart sensors of the hood. The product interface allows every single cooking and extraction zone to be simply and intuitively switched on, thanks to the specific new white backlit slider.

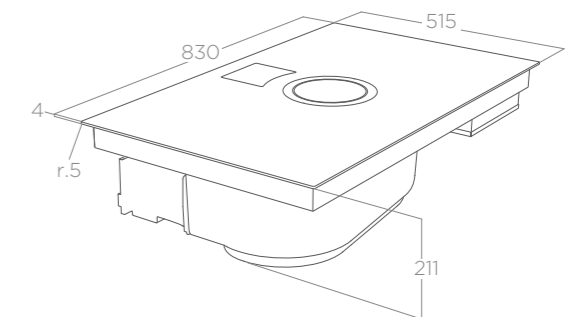

	ASPIRAZIONE DUCT-OUT	FILTRANTE FILTERING
Comandi Controls	Touch control slider 9V+I	Touch control slider 9V+I
Portata intensiva Booster airflow	630 m³/h	550 m³/h
Velocità di aspirazione Suction speed	5,1 m/s	5,1 m/s
Livello sonoro min-max Noise level min-max	33 - 66 db(A)	39 - 72 db(A)
Assorbimento totale Total absorption	175 W	175 W

Filtro grassi alluminio incluso Grease aluminium Filter included
Filtro in ceramica anti-odori rigenerabile HP incluso (*)
HP regenerable anti-odor ceramic filter included (*)

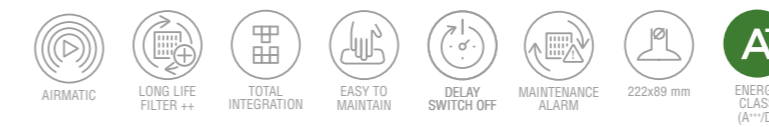

ACCESSORI ACCESSORIES	
Filtro in ceramica anti-odori rigenerabile HP HP regenerable anti-odor ceramic filter	KIT0120952A
Kit Nikolatesla filtrante per base profondità > 70 cm Nikolatesla filtering kit for base depth >70 cm	KIT0140820

(*) Modello non soggetto a certificazione energetica obbligatoria.
(*) Model not subject to compulsory energy certification.

	COTTURA COOKING
Comandi Controls	Touch control direct slider 9P+I 9P+B Touch control direct slider
Assorbimento Absorption	7,2 KW
Power limitation	3,1 - 4,5 kW
Voltaggio Voltage	220 - 240 V
Zone cottura Cooking zones (Misura-Potenza Size-Power)	1 210x191 mm - 2,1/3 kW 2 210x191 mm - 2,1/3 kW 3 210x191 mm - 2,1/3 kW 4 210x191 mm - 2,1/3 kW
Zone Bridge Bridge zone	2

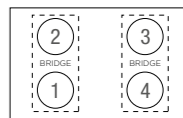

FUNZIONI FUNCTIONS
WARMING MODE
BRIDGE ZONES
STOP & GO
RECALL
CHILD LOCK
TIMER

MODELLI MODELS	
NIKOLATESLA SWITCH GLOW BL/A/83	PRF0183880
NIKOLATESLA SWITCH GLOW BL/F/83 (*)	PRF0183878

Grazie alla soluzione brevettata da Elica i filtri odori ceramici si estracono facilmente dall'alto con l'ausilio di un pratico nastro.
Thanks to our Elica patented solution, ceramic odor filters are easily removable from the top, with the help of a handy ribbon



NIKOLATESLA SWITCH

DESIGN FABRIZIO CRISÀ

83x51,5x21 cm
 80,7x49,2 cm (cut)
 Aspirante/Filtrante Duct-out/Filtering
 Vetro nero, vetro bianco "ICE GREY"
 Black glass, white glass "ICE GREY"

L'elemento estetico centrale nasconde il cuore aspirante del prodotto che può essere attivato con un semplice gesto anche in modalità completamente automatica, possibile grazie ai sensori intelligenti di cui il prodotto è dotato. L'interfaccia del prodotto permette di azionare, in modo semplice e intuitivo, ogni singola zona di cottura e aspirazione grazie allo slider dedicato. The central aesthetic element hides the extraction core of the product, which is activated with just one touch, and even automatically, thanks to the smart sensors of the hood. The product interface allows every single cooking and extraction zone to be simply and intuitively switched on, thanks to the specific slider.

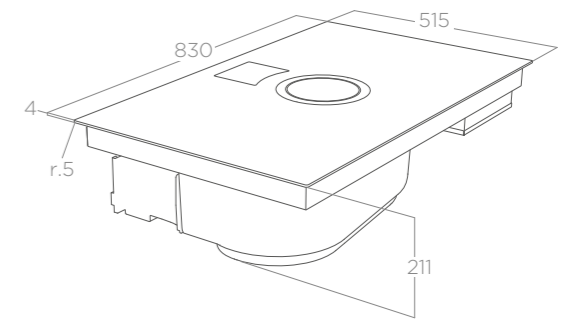
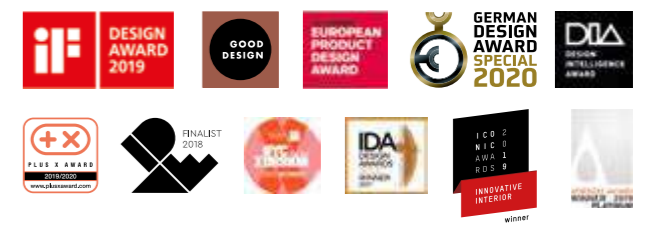

	ASPIRAZIONE DUCT-OUT	FILTRANTE FILTERING
Comandi Controls	Touch control slider 9V+I 9S+B Slider touch control	Touch control slider 9V+I 9S+B Slider touch control
Portata intensiva Booster airflow	630 m³/h	550 m³/h
Velocità di aspirazione Suction speed	5,1 m/s	5,1 m/s
Livello sonoro min-max Noise level min-max	33 - 66 db(A)	39 - 72 db(A)
Assorbimento totale Total absorption	175 W	175 W

	COTTURA COOKING
Comandi Controls	Touch control direct slider 9P+I 9P+B Touch control direct slider
Assorbimento Absorption	7,2 KW
Power limitation	3,1 - 4,5 kW
Voltaggio Voltage	220 - 240 V
Zone cottura Cooking zones (Misura-Potenza Size-Power)	1 210x191 mm - 2,1/3 kW 2 210x191 mm - 2,1/3 kW 3 210x191 mm - 2,1/3 kW 4 210x191 mm - 2,1/3 kW
Zone Bridge Bridge zone	2

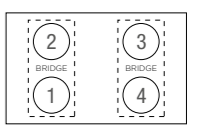

Filtro grassi alluminio incluso Grease aluminium Filter included
 Filtro in ceramica anti-odori rigenerabile HP incluso (*)
 HP regenerable anti-odor ceramic filter included (*)

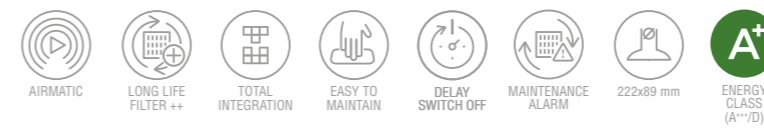

	ACCESSORI ACCESSORIES
Filtro in ceramica anti-odori rigenerabile HP HP regenerable anti-odor ceramic filter	KIT0120952A
Kit NikolaTesla filtrante per base profondità > 70 cm NikolaTesla filtering kit for base depth >70 cm	KIT0140820



	MODELLI MODELS
NIKOLATESLA SWITCH BL/A/83	PRF0146212A
NIKOLATESLA SWITCH BL/F/83 (*)	PRF0146210A
NIKOLATESLA SWITCH WH/A/83	PRF0146216A
NIKOLATESLA SWITCH WH/F/83 (*)	PRF0146213A

PATENTED Grazie alla soluzione brevettata da Elica i filtri odori ceramici si estraggono facilmente dall'alto con l'ausilio di un pratico nastro. Thanks to our Elica patented solution, ceramic odor filters are easily removable from the top, with the help of a handy ribbon

(*) Modello non soggetto a certificazione energetica obbligatoria.
 (*) Model not subject to compulsory energy certification.





NIKOLATESLA LIBRA

DESIGN FABRIZIO CRISA



NIKOLATESLA LIBRA

DESIGN FABRIZIO CRISÀ



83x51,5x21 cm
 80,7x49,2 cm (cut)
 Aspirante/Filtrante Duct-out/Filtering
 Vetro nero + ghisa, vetro bianco "ICE GREY" + ghisa
 Black glass + cast iron, white glass "ICE GREY" + cast iron

Il piano aspirante con bilancia integrata. Il design distintivo, con solide griglie in ghisa, veste le funzionalità dell'aspirazione dal basso e della pesatura, che si integrano armoniosamente a quelle della cottura ad induzione. L'interazione con il prodotto è facile e pratica grazie all'uso dello slider centrale. The extractor hob with integrated scale. Its distinctive design, with solid cast iron grates, covers the bottom extraction and weighing features, which harmoniously blend with those of the induction cooking. Interacting with the appliance is easy and practical, thanks to the central slider.

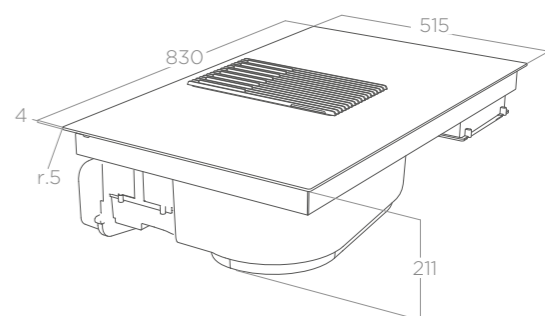

	ASPIRAZIONE ASPIRATION	
	ASPIRANTE DUCT-OUT	FILTRANTE FILTERING
Comandi Controls	Touch control slider 4V+2I 4S+2B slider touch control	Touch control slider 4V+2I 4S+2B slider touch control
Portata intensiva Booster airflow	610 m³/h	545 m³/h
Velocità di aspirazione Suction speed	5,1 m/s	5,1 m/s
Livello sonoro min-max Noise level min-max	46 - 69 db(A)	48 - 71 db(A)
Assorbimento totale Total absorption	250 W	250 W

	COTTURA COOKING	
Comandi Controls	Touch control slider 9P+I 9P+B slider touch control	
Assorbimento Absorption	7,2 KW	
Power limitation	3,1 - 4,5 KW	
Voltaggio Voltage	220 - 240 V	
Zone cottura Cooking zones (Misura-Potenza Size-Power)	1	210x191 mm - 1,6/1,85 KW
	2	210x191 mm - 2,1/3 KW
	3	210x191 mm - 2,1/3 KW
	4	210x191 mm - 1,6/1,85 KW
Zone Bridge Bridge zone	2	

Filtro grassi alluminio incluso Grease aluminium Filter included
 Filtro in ceramica anti-odori rigenerabile HP incluso (*)
 HP regenerable anti-odor ceramic filter included (*)

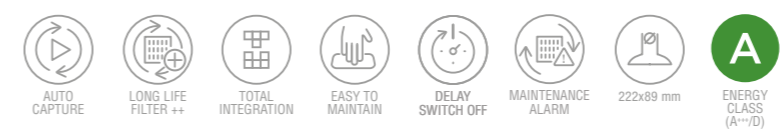

ACCESSORI ACCESSORIES	
Filtro in ceramica anti-odori rigenerabile HP HP regenerable anti-odor ceramic filter	KIT0120952A
Kit Nikolatesla filtrante per base profondità > 70 cm Nikolatesla filtering kit for base depth >70 cm	KIT0140820

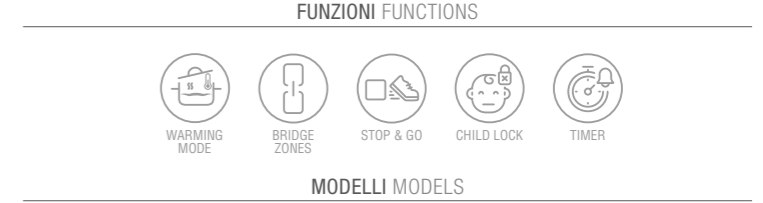

MODELLI MODELS	
NIKOLATESLA LIBRA BL/A/83	PRF0147744A
NIKOLATESLA LIBRA BL/F/83 (*)	PRF0147745A
NIKOLATESLA LIBRA WH/A/83	PRF0147774A
NIKOLATESLA LIBRA WH/F/83 (*)	PRF0147775A

In questo prodotto sono due le soluzioni brevettate da Elica. La prima riguarda i filtri odori ceramici che si estraggono facilmente dall'alto con l'ausilio di un pratico nastro e la seconda è una vera bilancia elettronica integrata al piano aspirante, che sfruttando lo spazio a disposizione, aggiunge funzionalità alla cottura e all'aspirazione. This product is equipped with two Elica patented solutions. The first is its ceramic odor filters that are easily removable from the top with the help of a handy ribbon. The second is a real electronic scale, integrated into the extractor hob that makes best use of available space, adding functionality to cooking and extraction.

(*) Modello non soggetto a certificazione energetica obbligatoria.
 (*) Model not subject to compulsory energy certification.





NIKOLATESLA FIT XL

DESIGN FABRIZIO CRISÀ



NIKOLATESLA FIT XL

DESIGN FABRIZIO CRISÀ

83x51,5x25 cm
75x49 cm (cut)
Aspirante Duct-out
Vetro nero
Black glass

La totale flessibilità di installazione e il design lineare del NikolaTesla FIT è ora disponibile anche nella dimensione da 80 cm. Il cuore di aspirazione è completamente invisibile e può essere attivato con un semplice gesto, inoltre grazie allo slider centrale interagire con il prodotto è ancora più facile e pratico. The total installation flexibility and linear design of NikolaTesla FIT, is now available in the 80 cm size. The extraction core is completely hidden and may be activated with just a simple touch. Furthermore, thanks to the central slider, interacting with the appliance is even easier and more practical.

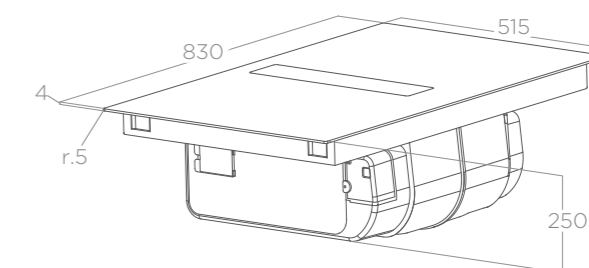

ASPIRAZIONE ASPIRATION

Comandi Controls	Touch control slider 4V+I 4S+B Slider touch control
Portata intensiva Booster airflow	620 m ³ /h
Velocità di aspirazione Suction speed	5,1 m/s
Livello sonoro min-max Noise level min-max	43 - 61 db(A)
Assorbimento totale Total absorption	160 W

Filtro grassi alluminio incluso Grease aluminium Filter included

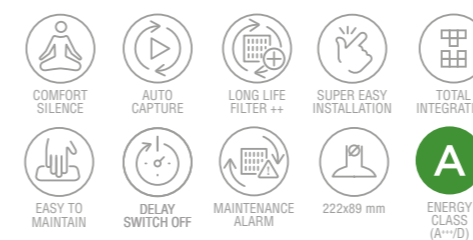

ACCESSORI ACCESSORIES

Filtro in ceramica anti-odori rigenerabile HP HP regenerable anti-odor ceramic filter	KIT0167755
Kit installazione filtrante sotto zoccolo Filtering Kit plinth-in	KIT0167756
Kit installazione filtrante fuori zoccolo Filtering Kit plinth-out	KIT0167757
Kit installazione filtrante uscita posteriore Filtering Kit back outlet	KIT0180522

COTTURA COOKING

Comandi Controls	Touch control slider 9P+I 9P+B Slider touch control
Assorbimento Absorption	7,2 KW
Power limitation	3,1 - 4,5 KW
Voltaggio Voltage	220 - 240 V
Zone cottura Cooking zones (Misura-Potenza Size-Power)	1 210x191 mm - 1,65/1,85 kW 2 210x191 mm - 2,1/3 kW 3 210x191 mm - 2,1/3 kW 4 210x191 mm - 1,65/1,85 kW
Zone Bridge Bridge zone	2

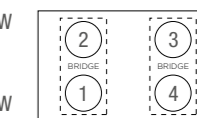

FUNZIONI FUNCTIONS



MODELLI MODELS

NIKOLATESLA FIT XL BL/A/83	PRF0179476
----------------------------	------------

PATENTED Grazie al sistema ventilante con doppio ingresso d'aria brevettato da Elica, il prodotto risulta particolarmente compatto e silenzioso. Thanks to the ventilation system with Elica patented dual air entry, the product is especially small and silent.



NIKOLATESLA FIT

DESIGN FABRIZIO CRISÀ



NIKOLATESLA FIT 72



NIKOLATESLA FIT 60



NIKOLATESLA FIT

DESIGN FABRIZIO CRISÀ

60x51,5x25 cm 72x51,5x25 cm
56x49 cm (cut)
Aspirante Duct-out
Vetro nero Black glass

Possibilità di installazione nell'incasso 60 cm senza sacrificare le prestazioni della cappa, la potenza delle zone di induzione, le dimensioni e la posizione della base. Il cuore di aspirazione è completamente invisibile e può essere attivato con un semplice gesto, inoltre grazie allo slider centrale interagire con il prodotto è ancora più facile e pratico. Can be built into 60-cm wide units without foregoing the hood performance, induction hob power, size and position of the base unit. The extraction core is completely hidden and may be activated with just a simple touch. Furthermore, thanks to the central slider, interacting with the appliance is even easier and more practical.

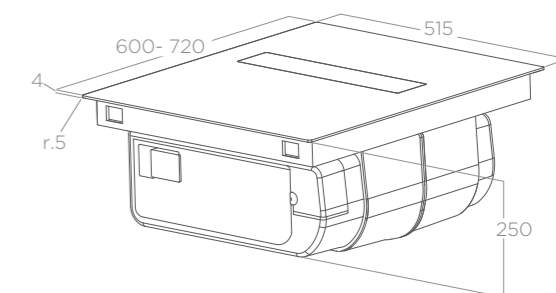
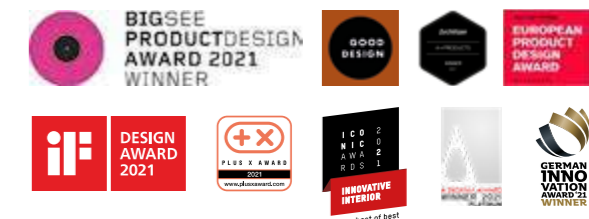

ASPIRAZIONE ASPIRATION

Comandi Controls	Touch control slider 4V+1 4S+B Slider touch control
Portata intensiva Booster airflow	620 m³/h
Velocità di aspirazione Suction speed	5,1 m/s
Livello sonoro min-max Noise level min-max	37 - 61 db(A)
Assorbimento totale Total absorption	160 W

Filtro grassi alluminio incluso Grease aluminium Filter included

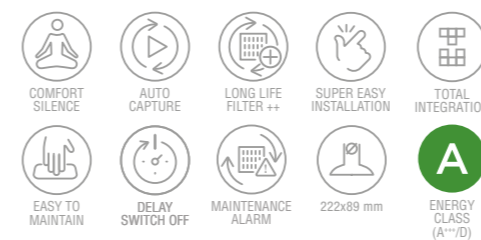

ACCESSORI ACCESSORIES

Filtro in ceramica anti-odori rigenerabile HP HP regenerable anti-odor ceramic filter	KIT0167755
Kit installazione filtrante sotto zoccolo Filtering Kit plinth-in	KIT0167756
Kit installazione filtrante fuori zoccolo Filtering Kit plinth-out	KIT0167757
Kit installazione filtrante uscita posteriore Filtering Kit back outlet	KIT0180522

COTTURA COOKING

Comandi Controls	Touch control slider 9P+1 9P+B Slider touch control
Assorbimento Absorption	7,2 KW
Power limitation	3,1 - 4,5 kW
Voltaggio Voltage	220 - 240 V
Zone cottura Cooking zones (Misura-Potenza Size-Power)	1 210x191 mm - 2,1/3 kW 2 210x191 mm - 1,65/1,85 kW 3 Ø200 mm - 2,3/3 kW 4 Ø160 mm - 1,2/1,4 kW
Zone Bridge Bridge zone	1 sinistra left

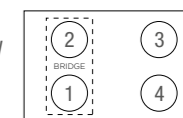

FUNZIONI FUNCTIONS



MODELLI MODELS

NIKOLATESLA FIT BL/A/60	PRF0167053
NIKOLATESLA FIT BL/A/72	PRF0167054



Grazie al sistema ventilante con doppio ingresso d'aria brevettato da Elica, il prodotto risulta particolarmente compatto e silenzioso. Thanks to the ventilation system with Elica patented dual air entry, the product is especially small and silent.



NIKOLATESLA FIT 3Z

DESIGN FABRIZIO CRISÀ



NIKOLATESLA FIT 3Z 60



NIKOLATESLA FIT 3Z 72



NIKOLATESLA FIT 3Z

DESIGN FABRIZIO CRISÀ

60x51,5x26 cm 72x51,5x26 cm
56x49 cm (cut)
Aspirante Duct-out
Vetro nero Black glass

Il primo piano aspirante a tre zone sul mercato. Che tu voglia cucinare per la famiglia o per gli amici, l'ampia zona da 30cm ti permette l'utilizzo di pentole di qualsiasi dimensione. Il cuore di aspirazione è completamente invisibile e può essere attivato con un semplice gesto e inoltre, grazie allo slider centrale, interagire con il prodotto è ancora più facile e pratico. First three zone extractor hob on the market. Whether cooking for family or friends, the large 30cm zone allows you to use any size cookware. The extraction core is completely hidden and can be activated with just a simple touch, and what's more, thanks to the central slider, interacting with the appliance is even easier and more practical.

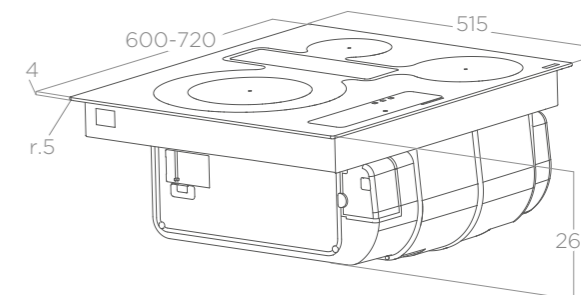

ASPIRAZIONE ASPIRATION

Comandi Controls	Touch control slider 4V+I 4S+B Slider touch control
Portata intensiva Booster airflow	600 m ³ /h
Velocità di aspirazione Suction speed	5,1 m/s
Livello sonoro min-max Noise level min-max	42 - 61 db(A)
Assorbimento totale Total absorption	160 W

Filtro grassi alluminio incluso Grease aluminium Filter included

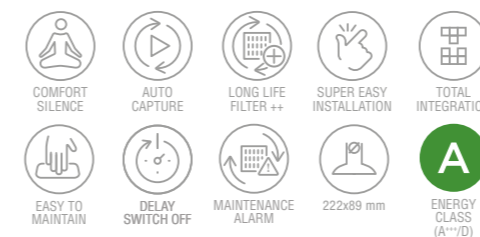

ACCESSORI ACCESSORIES

Filtro in ceramica anti-odori rigenerabile HP HP regenerable anti-odor ceramic filter	KIT0167755
Kit installazione filtrante sotto zoccolo Filtering Kit plinth-in	KIT0167756
Kit installazione filtrante fuori zoccolo Filtering Kit plinth-out	KIT0167757
Kit installazione filtrante uscita posteriore Filtering Kit back outlet	KIT0180522

COTTURA COOKING

Comandi Controls	Touch control slider 9P+I 9P+B Slider touch control
Assorbimento Absorption	7,2 KW
Power limitation	3,1 - 4,5 kW
Voltaggio Voltage	220 - 240 V
Zone cottura Cooking zones (Misura-Potenza Size-Power)	1 Ø300 mm - 2,5/3,6 kW 2 Ø180 mm - 2,1/2,5 kW 3 Ø180 mm - 1,4/2,1 kW

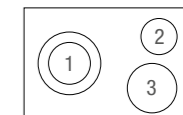

FUNZIONI FUNCTIONS



MODELLI MODELS

NIKOLATESLA FIT 3Z BL/A/60	PRF0184526
NIKOLATESLA FIT 3Z BL/A/72	PRF0184551

DISPONIBILE A PARTIRE DA APRILE 2023 AVAILABLE FROM APRIL 2023

PATENTED Grazie al sistema ventilante con doppio ingresso d'aria brevettato da Elica, il prodotto risulta particolarmente compatto e silenzioso. Thanks to the ventilation system with Elica patented dual air entry, the product is especially small and silent.



NIKOLATESLA PRIME S

DESIGN FABRIZIO CRISÀ

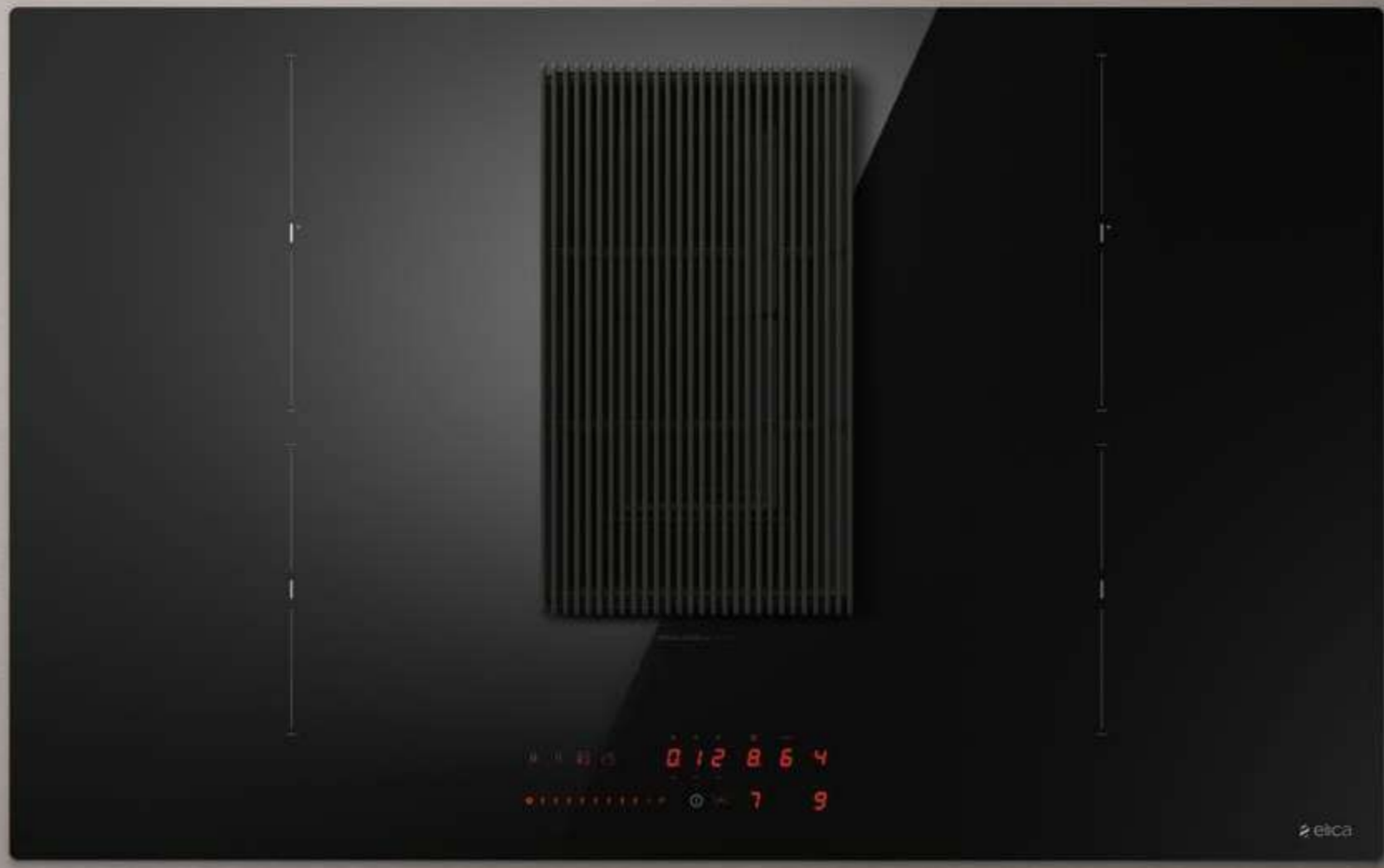

NIKOLATESLA PRIME S

DESIGN FABRIZIO CRISÀ



83x51,5x25 cm
75x49 cm (cut)
Aspirante Duct-out
Vetro nero + alluminio effetto ghisa
Black glass + aluminium cast iron effect

L'elegante e solida griglia in alluminio coniuga la scelta di design alla funzionalità della cattura di fumi e odori al pratico piano di appoggio. Grazie allo slider centrale interagire con il prodotto è ancora più facile e pratico. The elegant and sturdy aluminum grates, combines design needs with fume and odor capturing features with the practical worktop. The central slider makes interacting with the appliance even easier and more practical.

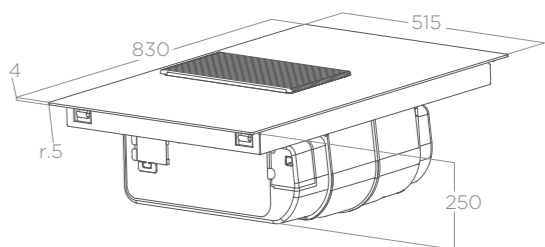

	ASPIRAZIONE ASPIRATION	
	ASPIRANTE DUCT-OUT	FILTRANTE FILTERING
Comandi Controls	Touch control slider 4V+I 4S+B Slider touch control	Touch control slider 4V+I 4S+B Slider touch control
Portata intensiva Booster airflow	620 m³/h	535 m³/h
Velocità di aspirazione Suction speed	5,1 m/s	5,1 m/s
Livello sonoro min-max Noise level min-max	44 - 63 db(A)	49 - 69 db(A)
Assorbimento totale Total absorption	160 W	160 W

	COTTURA COOKING	
Comandi Controls	Touch control slider 9P+I 9P+B slider touch control	
Assorbimento Absorption	7,2 KW	
Power limitation	3,1 - 4,5 kW	
Voltaggio Voltage	220 - 240 V	
Zone cottura Cooking zones (Misura-Potenza Size-Power)	1 Ø160 mm - 1,2/1,4 kW	2 Ø200 mm - 2,3/3 kW
	3 Ø200 mm - 2,3/3 kW	4 Ø160 mm - 1,2/1,4 kW

Filtro grassi alluminio incluso Grease aluminium Filter included
Filtro in ceramica anti-odori rigenerabile HP incluso (*)
HP regenerable anti-odor ceramic filter included (*)

FUNZIONI FUNCTIONS

MODELLI MODELS

NIKOLATESLA PRIME S BL/A P/83	PRF0185059
NIKOLATESLA PRIME S BL/F PO/83 (*)	PRF0185060

ACCESSORI ACCESSORIES

Filtro in ceramica anti-odori rigenerabile HP KIT0167755
HP regenerable anti-odor ceramic filter

PATENTED Grazie al sistema ventilante con doppio ingresso d'aria brevettato da Elica, il prodotto risulta particolarmente compatto e silenzioso. Thanks to the ventilation system with Elica patented dual air entry, the product is especially small and silent.

(*) Modello non soggetto a certificazione energetica obbligatoria.
(*) Model not subject to compulsory energy certification.





NIKOLATESLA ALPHA
DESIGN FABRIZIO CRISÀ



NIKOLATESLA ALPHA

DESIGN FABRIZIO CRISÀ

78x51,5x25 cm
75x49 cm (cut)
Aspirante Duct-out
Vetro nero
Black glass



L'essenza del piano aspirante dai dettagli in alluminio nero che si adatta perfettamente a qualsiasi stile di cucina. Grazie allo slider centrale interagire con il prodotto è ancora più facile e pratico.

The sleek look of the extractor hob with black aluminum details, perfectly adapts to any kitchen style. Thanks to the central slider, interacting with the appliance is even easier and more practical.

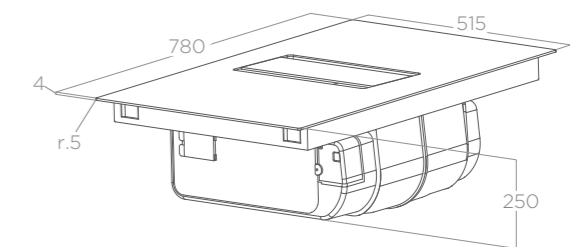

ASPIRAZIONE ASPIRATION

Comandi Controls	Touch control slider 4V+I 4S+B Slider touch control
Portata intensiva Booster airflow	580 m³/h
Velocità di aspirazione Suction speed	5,1 m/s
Livello sonoro min-max Noise level min-max	43 - 61 db(A)
Assorbimento totale Total absorption	160 W

Filtro grassi alluminio incluso Grease aluminium Filter included

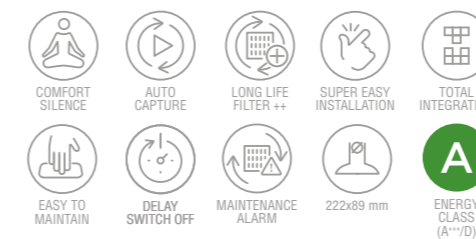

ACCESSORI ACCESSORIES

Filtro in ceramica anti-odori rigenerabile HP HP regenerable anti-odor ceramic filter	KIT0167755
Kit installazione filtrante sotto zoccolo Filtering Kit plinth-in	KIT0167756
Kit installazione filtrante fuori zoccolo Filtering Kit plinth-out	KIT0167757
Kit installazione filtrante uscita posteriore Filtering Kit back outlet	KIT0180522

COTTURA COOKING

Comandi Controls	Touch control slider 9P+I 9P+B slider touch control
Assorbimento Absorption	7,2 KW
Power limitation	3,1 - 4,5 kW
Voltaggio Voltage	220 - 240 V
Zone cottura Cooking zones (Misura-Potenza Size-Power)	1 Ø160 mm - 1,2/1,4 kW 2 Ø200 mm - 2,3/3 kW 3 Ø200 mm - 2,3/3 kW 4 Ø160 mm - 1,2/1,4 kW

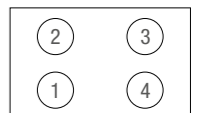

FUNZIONI FUNCTIONS

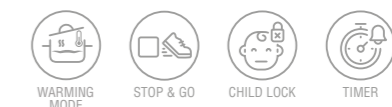

MODELLI MODELS

NIKOLATESLA ALPHA BL/A/78 PRF0183127



Grazie al sistema ventilante con doppio ingresso d'aria brevettato da Elica, il prodotto risulta particolarmente compatto e silenzioso. Thanks to the ventilation system with Elica patented dual air entry, the product is especially small and silent.





NIKOLATESLA FLAME
DESIGN FABRIZIO CRISÀ



NIKOLATESLA FLAME

DESIGN FABRIZIO CRISÀ



88x51x21 cm
84x48,7cm (cut)
Aspirante/Filtrante Duct-out/Filtering
Vetro nero + ghisa, vetro grigio + ghisa
Black glass + cast iron, grey glass + cast iron

Innovazione e tradizione si incontrano dando vita al primo piano aspirante a gas sul mercato. Gli elementi in ghisa del piano sono disegnati per coniugare estetica e funzionalità, nella massima sicurezza. Le griglie a croce chiuse e piatte garantiscono stabilità con pentole di tutte le dimensioni e facilità nello spostamento sul piano cottura. La copertura della zona filtri in ghisa diventa un pratico piano di appoggio. Il supporto wok, disponibile come accessorio, aumenta le varianti di cottura su NikolaTesla Flame. Innovation and tradition meet to create the first gas extractor hob on the market. The cast iron elements of the top are designed to combine aesthetic appeal and functionality with the utmost safety. The closed cross and flat grid supports guarantee stability with pans of any size and ease when moving on the cooking area. The cast iron filter cover doubles as a practical work surface. The wok support, available as an accessory, increases the cooking variations on NikolaTesla Flame.

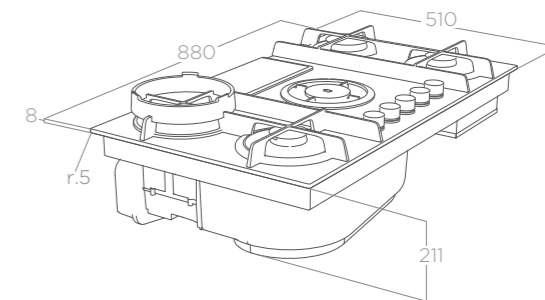

	ASPIRAZIONE DUCT-OUT	FILTRANTE FILTERING
Comandi Controls	Rotativo 3V+2I 3S+2B Rotative	Rotativo 3V+2I 3S+2B Rotative
Portata intensiva Booster airflow	600 m ³ /h	530 m ³ /h
Velocità di aspirazione Suction speed	5,1 m/s	5,1 m/s
Livello sonoro min-max Noise level min-max	45 - 63 db(A)	49 - 69 db(A)
Assorbimento totale Total absorption	250 W	250 W

Filtro grassi alluminio incluso Grease aluminium Filter included
Filtro in ceramica anti-odori rigenerabile HP incluso (*)
HP regenerable anti-odor ceramic filter included (*)



ACCESSORI ACCESSORIES	
Filtro in ceramica anti-odori rigenerabile HP HP regenerable anti-odor ceramic filter	KIT0120952A
Kit wok Flame	KIT0160040
Kit NikolaTesla filtrante per base profondità > 70 cm NikolaTesla filtering kit for base depth >70 cm	KIT0140820

(*) Modello non soggetto a certificazione energetica obbligatoria.
(*) Model not subject to compulsory energy certification.

COTTURA COOKING	
Comandi Controls	Rotativo Rotative
Voltaggio Voltage	220 - 240 V

TIPOLOGIA BRUCIATORI BURNER TYPE	
1° elemento 1st element	Semi rapid (1,75 kW)
2° elemento 2nd element	Dual special (3,5kW)
3° elemento 3rd element	Rapid (3 kW)
4° elemento 4th element	Semi rapid (1,75 kW)

FUNZIONI FUNCTIONS



MODELLI MODELS	
NIKOLATESLA FLAME BL/A/88	PRF0147740A
NIKOLATESLA FLAME BL/F/88 (*)	PRF0147741A
NIKOLATESLA FLAME GR/A/88	PRF0147742A
NIKOLATESLA FLAME GR/F/88 (*)	PRF0147743A

PATENTED
In questo prodotto sono due le soluzioni brevettate da Elica. La prima riguarda i filtri odori ceramici che si estraggono facilmente dall'alto con l'ausilio di un pratico nastro. Grazie al secondo e più importante brevetto è possibile cucinare in completa sicurezza, aspirando vapori e odori dal basso, senza compromettere l'efficienza dei bruciatori a gas. This product is equipped with two Elica patented solutions. The first is its ceramic odor filters that are easily removable from the top with the help of a handy ribbon. Thanks to the second, which is the most important patent, it is possible to cook in total safety, extracting vapors and odors from below, without compromising the efficiency of the gas burners.



KIT WOK FLAME
disponibile come accessorio - available as accessory



Tutti i piani aspiranti NikolaTesla presentano una grande flessibilità di installazione. Per rispondere alla gran parte delle casistiche di montaggio, Elica ha progettato molteplici soluzioni di installazione che andremo a descrivere nella sezione che segue. In questo modo, ogni caratteristica strutturale del prodotto scelto potrà essere sfruttata al meglio in fase di montaggio.

All NikolaTesla extractor hobs allow for very flexible installation. In order to meet most installation needs, Elica has developed various installation solutions that will be explained in the following section. As a result, the structural characteristics of the appliance chosen will make installation operations easier.

NIKOLATESLA ALPHA - FIT - FIT XL - FIT 3Z

VERSIONE ASPIRANTE - COSA C'È NELL'IMBALLO DUCT OUT MODE - WHAT'S IN THE BOX

Questi modelli di NikolaTesla, nella versione aspirante, garantiscono grande flessibilità di montaggio. Le tubazioni accessorie che Elica mette a disposizione (acquistabili separatamente) permettono di canalizzare i fumi verso il punto di uscita esterno all'abitazione, assicurando elevate prestazioni e minima rumorosità.

These NikolaTesla models guarantee great installation flexibility, in the duct out version. The optional piping offered by Elica (sold separately) allows fumes to be conveyed towards an outlet found outside the home, thus ensuring high performance and very low noise levels.



Nell'imballo
In the box



Esempio di installazione
Example of installation

VERSIONE FILTRANTE FILTERING MODE

Per convertire il prodotto nella versione filtrante, Elica ha progettato 3 differenti kit da utilizzare a seconda dell'esigenza di installazione.

Elica has designed 3 different kits to convert the product to the filtering mode, to be used according to installation needs.



Installazione "PLINTH IN"
Installation "PLINTH IN"



Installazione "PLINTH OUT"
Installation "PLINTH OUT"



Installazione "BACK OUTLET"
Installation "BACK OUTLET"

KIT0167756 | KIT INSTALLAZIONE FILTRANTE SOTTO ZOCCOLO (MIN H6CM) "PLINTH IN" FILTERING INSTALLATION KIT UNDER PLINTH (MIN H6CM) "PLINTH IN"

Partendo dal prodotto acquistato in modalità aspirante, questo kit permette di installarlo in modalità filtrante. L'aria filtrata sarà convogliata all'interno della base del mobile. E' previsto un profilo di rifinitura cromato per l'eventuale fessura di sfogo praticata sullo zoccolo del mobile stesso.

If the product purchased is in duct out mode, this kit will allow it to be installed in filtering mode. The filtered air will be conveyed into the cabinet base.

A chrome-plated trim profile is provided for any vent slot, made in the cabinet baseboard.



- Filtri ceramici (2 pezzi)
- Curva rettangolare 90° - 94 x 227 mm
- Tubo rettangolare 500 x 94 x 227 mm
- Curva rettangolare 90° da vert. 94 x 227 mm a orizz. 55 x 227 mm
- Deflettore sotto lo zoccolo
- Profilo estetico cromato
- Nastro adesivo
- Ceramic filters (2 pieces)
- 90° - 94 x 227 mm rectangular bend
- 500 x 94 x 227 mm rectangular pipe
- 90° rectangular bend from vert. 94 x 227 mm to horiz. 55 x 227 mm
- Under baseboard deflector
- Chrome-plated trim profile
- Adhesive Tape

KIT0167757 | KIT INSTALLAZIONE FILTRANTE FUORI ZOCCOLO (MIN H6CM) "PLINTH OUT" FILTERING INSTALLATION KIT OUT OF THE PLINTH (MIN H6CM) "PLINTH OUT"

Acquistando questo kit, si può convertire e installare il prodotto in modalità filtrante convogliando l'aria depurata fino a farla uscire dallo zoccolo stesso con l'aiusilio di una speciale tubazione ad imbuto che termina con un profilo estetico a rifinitura del foro di sfogo.

By purchasing this kit, it is possible to convert and install the product in filtering mode, thus conveying purified air into, and then outside the baseboard, through a special funnel-shaped pipe with an aesthetic profile on its edge, finishing the vent hole.



- Filtri ceramici 2 pezzi
- Curva rettangolare 90° - 94 x 227 mm
- Tubo rettangolare 500 x 94 x 227 mm
- Curva rettangolare 90° da vert. 94 x 227 mm a orizz. 50 x 227 mm
- Raccordo di uscita esterno allo zoccolo completo di profilo cromato
- Tubo rettangolare 218 x 55 x 300 mm
- Supporto per raccordo di uscita
- Nastro adesivo
- Ceramic filters, 2 pieces
- 90° - 94 x 227 mm rectangular bend
- 500 x 94 x 227 mm rectangular pipe
- 90° rectangular bend from vert. 94 x 227 mm to horiz. 50 x 227 mm
- Outlet connection to be fitted outside the baseboard, provided with chrome-plated trim profile
- 218 x 55 x 300 mm rectangular pipe
- Outlet connection support
- Adhesive tape

KIT0180522 | KIT INSTALLAZIONE FILTRANTE "BACK OUTLET" FILTERING INSTALLATION KIT "BACK OUTLET"

Questo kit permette la conversione del prodotto in modalità filtrante. In flusso dell'aria viene convogliato posteriormente e lasciato defluire, nella maniera più semplice possibile, all'interno dell'intercapedine tra la parete e il mobile senza l'aiusilio di tubazioni aggiuntive.

This kit allows the product to be converted into filtering mode. The air flow is conveyed backwards and left to flow, in the simplest possible way, into the interspace between the wall and the cabinet without the use of any additional pipes.



- Filtri ceramici 2 pezzi
- Raccordo di uscita telescopico
- Profilo estetico cromato
- Ceramic filters, 2 pieces
- Telescopic outlet connection
- Chrome-plated trim profile

NIKOLATESLA UNPLUGGED - SWITCH GLOW - SWITCH ONE HP - ONE - LIBRA - PRIME S - FLAME

Anche questa piattaforma è stata pensata per garantire la massima flessibilità di installazione ottimizzando gli spazi interni del cabinet.

I NikolaTesla che si basano su questa piattaforma, sono acquistabili sia nella versione aspirante che nella versione filtrante.

In entrambi i casi, il prodotto è fornito completo per essere installato (nelle versioni di base). Per ulteriori esigenze di montaggio sono a disposizione, come accessori, curve e tubazioni.

This platform has also been designed to guarantee maximum installation flexibility by optimizing space inside the cabinet.

NikolaTesla models associated with this platform can be purchased both in duct out and filtering version.

In both cases, the product is supplied 'ready' for installation (in the basic versions). In case of different installation needs, bends and pipes are available to be purchased as accessories.

VERSIONE FILTRANTE - COSA C'È NELL'IMBALLO FILTERING MODE - WHAT'S IN THE BOX

Acquistando il codice del prodotto nella versione filtrante, all'interno dell'imballo è già presente tutto l'occorrente per installare il Nikolatesla con uscita canalizzata fino allo zoccolo, incluso l'esclusivo profilo cromato che rifinisce il taglio dello zoccolo necessario per l'uscita dell'aria.

If the filtering version product code has been purchased, the packaging will contain everything needed to install Nikolatesla with a ducted outlet to the cabinet baseboard, including the exclusive chrome-plated trim profile to finish the baseboard cut, necessary for air outlet.

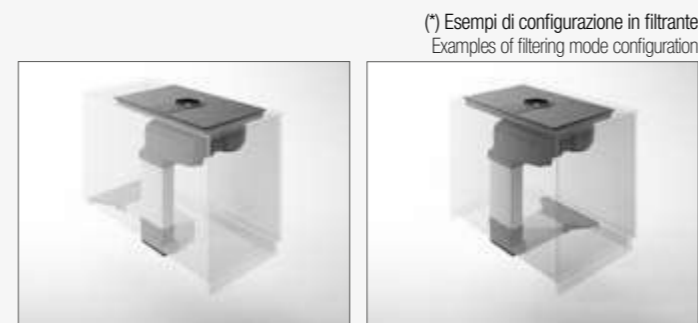

(*) Esempi di configurazione in filtrante
Examples of filtering mode configuration

Nell'imballo (versione filtrante PLINTH OUT) (*) In the box (filtering mode PLINTH OUT)



- Filtri ceramici (3 pezzi)
- Assieme telaio per filtri ceramici
- Curva rettangolare 90° - 94 x 227 mm
- Curva rettangolare 90° da vert. 94 x 227 mm a orizz. 50 x 227 mm
- Tubo rettangolare 500 x 94 x 227 mm
- Tubo rettangolare 218 x 55 x 300 mm
- Raccordo di uscita esterno allo zoccolo completo di profilo cromato
- 2 raccordi prolunga per cabinet >60 e >65
- Supporti per raccordo di uscita
- Nastro adesivo
- Ceramic filters (3 pieces)
- Ceramic filter frame assembly
- 90° - 94 x 227 mm Rectangular bend
- 90° rectangular bend from vert. 94 x 227 mm to horiz. 50 x 227 mm
- 500 x 94 x 227 mm rectangular pipe
- 218 x 55 x 300 mm rectangular pipe
- Outlet connection to fit outside the baseboard, provided with chrome-plated trim profile
- 2 extension connections for >60 and >65 cabinet
- Outlet connection supports
- Adhesive tape

(*) Per il NIKOLATESLA PRIME S le tubazioni contenute nell'imballo potrebbero differire dall'immagine. Fare riferimento al manuale di installazione.
(*) For NIKOLATESLA PRIME S the pipes contained in the packaging may differ from the image. Refer to the installation manual.

VERSIONE ASPIRANTE - COSA C'È NELL'IMBALLO DUCT-OUT VERSION - WHAT'S IN THE BOX

Nell'imballo (versione aspirante) (*) In the box (duct-out version)



- Raccordo uscita posteriore
- Curva rettangolare 90° - 94 x 227 mm
- Raccordo 15° (4 pezzi)
- Tubo rettangolare 500 x 94 x 227 mm
- Rear outlet connection
- 90° - 94 x 227 mm rectangular bend
- 15° connection (4 pieces)
- 500 x 94 x 227 mm rectangular pipe

Acquistando il codice del prodotto aspirante, all'interno dell'imballo sono già presenti le tubazioni per la configurazione di partenza da cui poi è possibile raggiungere l'uscita fumi all'esterno dell'abitazione acquistando separatamente le tubazioni accessorie necessarie.

If the duct out version product code has been purchased, the packaging will contain all piping to install the product in this mode. Any necessary piping to connect to the air/fume outlet outside the house, shall be purchased as separate accessories.



(*) Esempi di configurazione in aspirante con uscita laterale
Example of duct-out mode configuration with lateral outlet



(*) Esempio di configurazione aspirante con uscita posteriore
Example of duct out mode configuration with rear outlet

È possibile la configurazione in aspirante anche con uscita verso il muro posteriore acquistando separatamente le tubazioni necessarie.

Configuration in duct out mode with the air outlet in the rear wall, is also possible and the necessary piping shall be purchased as separate accessories.

(*) Per il NIKOLATESLA PRIME S le tubazioni contenute nell'imballo potrebbero differire dall'immagine. Fare riferimento al manuale di installazione.
(*) For NIKOLATESLA PRIME S the pipes contained in the packaging may differ from the image. Refer to the installation manual.

KIT0140820 | KIT FILTRANTE PER MOBILI PROFONDI FILTERING MODE KIT FOR DEEP CABINETS

Per esigenze di installazione legate a mobili cucina di una profondità maggiore alla standard, Elica mette a disposizione un kit per spostare la tubazione più indietro possibile così da massimizzare la capienza dei cassetti.

In the case of installation in kitchen cabinets deeper than standard ones, Elica provides a kit to move the piping as far backward as possible, in order to maximize drawer capacity.



- Raccordo prolunga per cabinet > 70 cm
- Curva rettangolare 90° - 94 x 227 mm
- Raccordo flessibile 218 x 55 mm
- Extension connection for > 70 cm cabinet
- 90° - 94 x 227 mm rectangular bend
- 218 x 55 mm flexible connection

Disponibile per i modelli Available for models
NIKOLATESLA ONE/ONE HP/SWITCH GLOW/
SWITCH/UNPLUGGED/LIBRA/FLAME

Esempi di configurazione in filtrante con mobile profondo
Examples of filtering mode configuration with deep cabinet

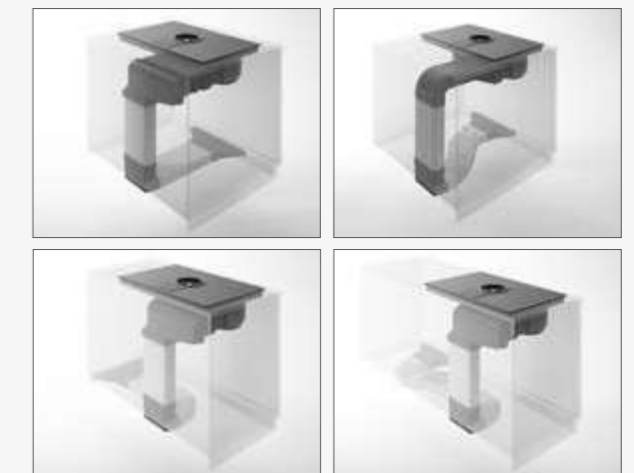

	DISPONIBILE IN AVAILABLE IN	TUBAZIONI NELL'IMBALLO PIPES IN THE PACKAGE	KIT DI CONVERSIONE IN MODALITÀ FILTRANTE FILTERING INSTALLATION KIT	H PRODOTTO PRODUCT H
NIKOLATESLA ALPHA	Aspirante Duct-out	no	PLINTH IN / PLINTH OUT / BACK OUTLET	25 cm
NIKOLATESLA FIT	Aspirante Duct-out	no	PLINTH IN / PLINTH OUT / BACK OUTLET	25 cm
NIKOLATESLA FIT XL	Aspirante Duct-out	no	PLINTH IN / PLINTH OUT / BACK OUTLET	25 cm
NIKOLATESLA FIT 3Z	Aspirante Duct-out	no	PLINTH IN / PLINTH OUT / BACK OUTLET	26 cm
NIKOLATESLA PRIME S	Aspirante Duct-out	si/yes	---	25 cm
	Filtrante Filtering	si/yes (PLINTH OUT)	---	
NIKOLATESLA UNPLUGGED	Aspirante Duct-out	si/yes	---	21 cm
	Filtrante Filtering	si/yes (PLINTH OUT)	---	
NIKOLATESLA SWITCH GLOW	Aspirante Duct-out	si/yes	---	21 cm
	Filtrante Filtering	si/yes (PLINTH OUT)	---	
NIKOLATESLA SWITCH	Aspirante Duct-out	si/yes	---	21 cm
	Filtrante Filtering	si/yes (PLINTH OUT)	---	
NIKOLATESLA ONE HP NIKOLATESLA ONE	Aspirante Duct-out	si/yes	---	21 cm
	Filtrante Filtering	si/yes (PLINTH OUT)	---	
NIKOLATESLA LIBRA	Aspirante Duct-out	si/yes	---	21 cm
	Filtrante Filtering	si/yes (PLINTH OUT)	---	
NIKOLATESLA FLAME	Aspirante Duct-out	si/yes	---	21 cm
	Filtrante Filtering	si/yes (PLINTH OUT)	---	



NIKOLATESLA ALPHA NIKOLATESLA FIT NIKOLATESLA FIT XL NIKOLATESLA FIT 3Z NIKOLATESLA FLAME NIKOLATESLA LIBRA



NIKOLATESLA ONE HP/ONE NIKOLATESLA PRIME S NIKOLATESLA SWITCH NIKOLATESLA SWITCH GLOW NIKOLATESLA UNPLUGGED

TUBAZIONI ACCESSORIE PER VERSIONE ASPIRANTE
ACCESSORY PIPE FITTINGS FOR DUCT-OUT VERSION

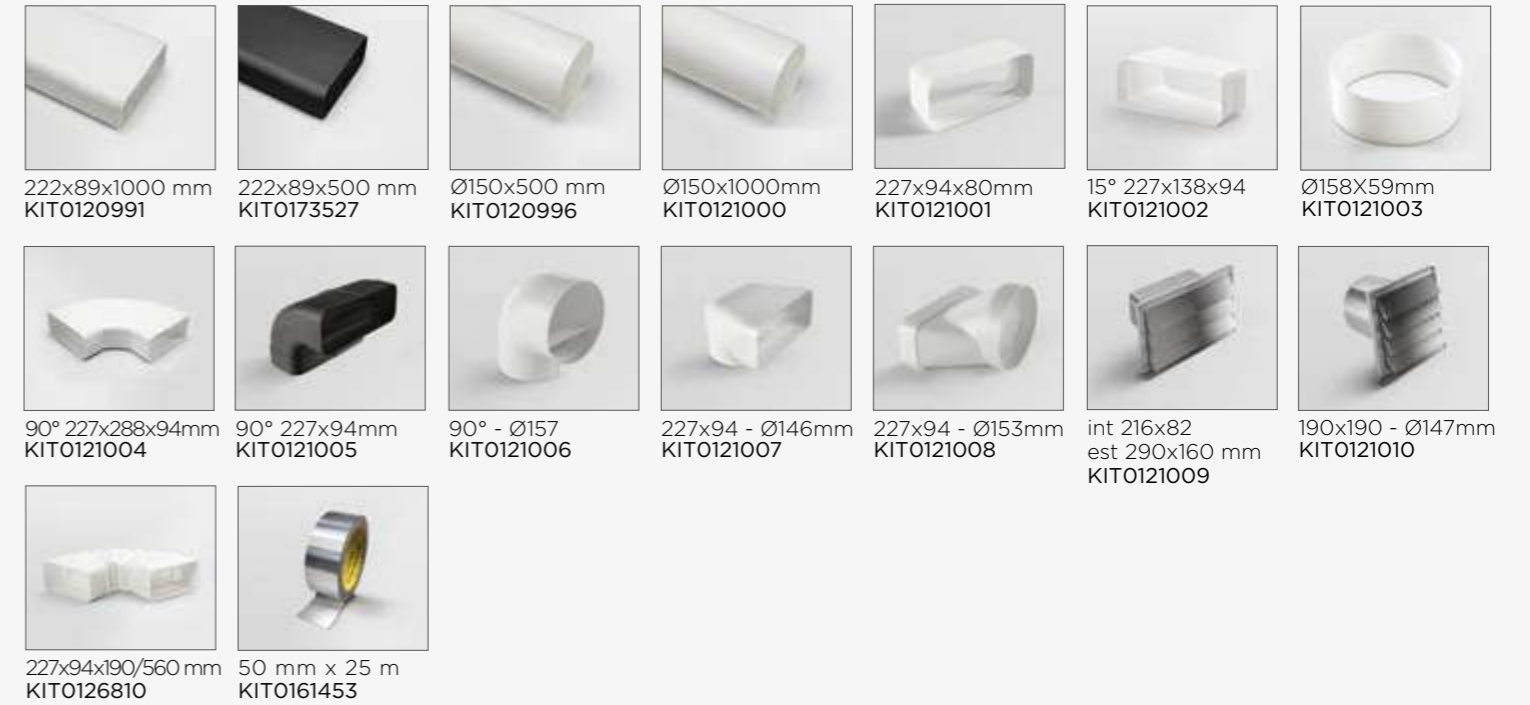

TUBAZIONI ACCESSORIE PER VERSIONE FILTRANTE
ACCESSORY PIPE FITTINGS FOR FILTERING VERSION

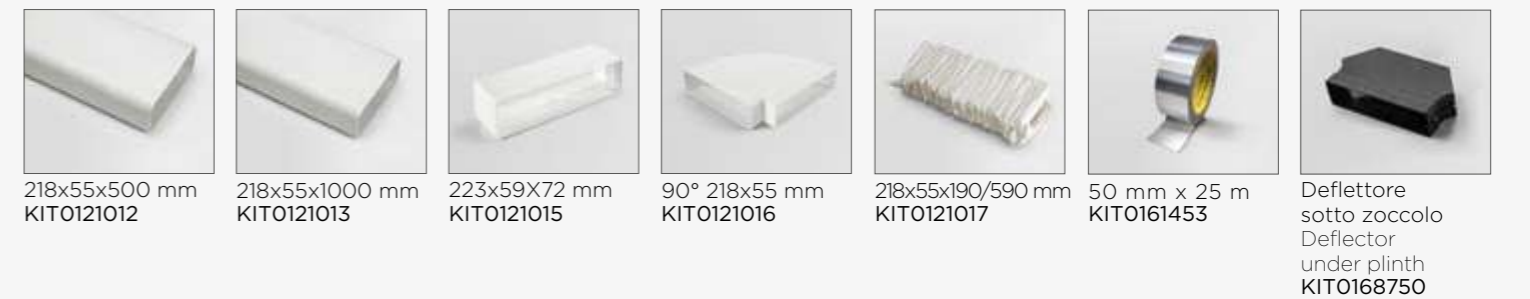

FILTRO IN CERAMICA ANTI-ODORI RIGENERABILE HP
HP REGENERABLE ANTI-ODOR CERAMIC FILTER

Il filtro ceramico è un filtro carbone modulare che si rigenera termicamente in forno ogni 2/3 mesi a 200° per 45 minuti, fino ad un massimo di 5 anni. Permette di raggiungere un'altissima efficienza di assorbimento odori ed un'elevata resistenza meccanica.

The ceramic filter is a modular charcoal filter that can be thermally regenerated in the oven every 2/3 months at 200° for 45 minutes, up to max 5 years. It allows for very high odour absorption efficiency and very high mechanical strength.



KIT0120952A
DISPONIBILE PER Available for
NIKOLATESLA ONE
NIKOLATESLA ONE HP
NIKOLATESLA UNPLUGGED
NIKOLATESLA SWITCH GLOW
NIKOLATESLA SWITCH
NIKOLATESLA LIBRA
NIKOLATESLA FLAME



KIT0167755
DISPONIBILE PER Available for
NIKOLATESLA ALPHA
NIKOLATESLA FIT
NIKOLATESLA FIT XL
NIKOLATESLA 3Z
NIKOLATESLA PRIME S

NIKOLATESLA ALPHA

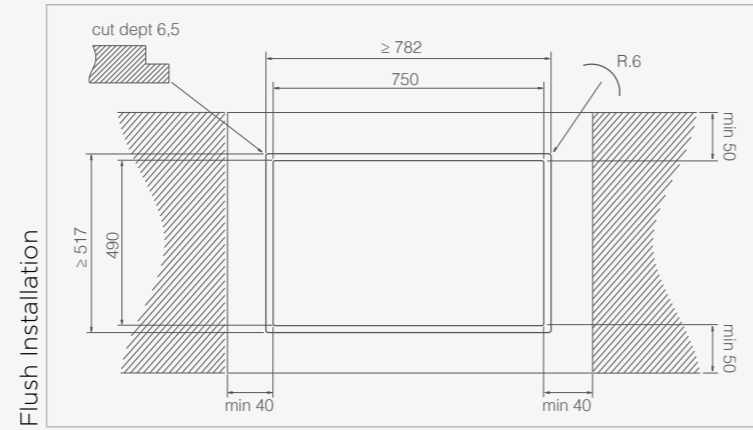
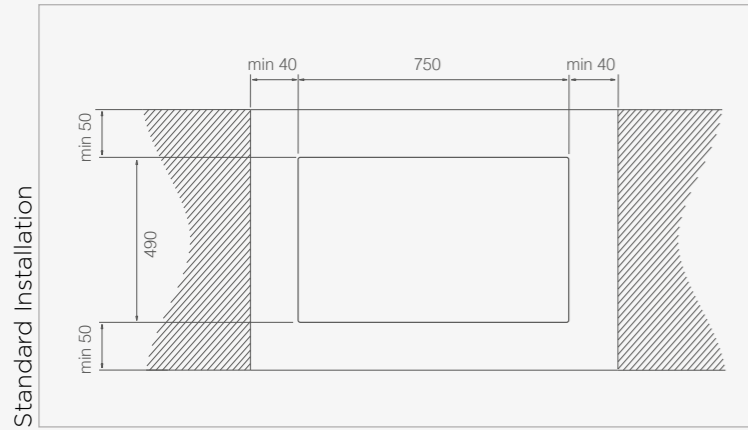

NIKOLATESLA FIT

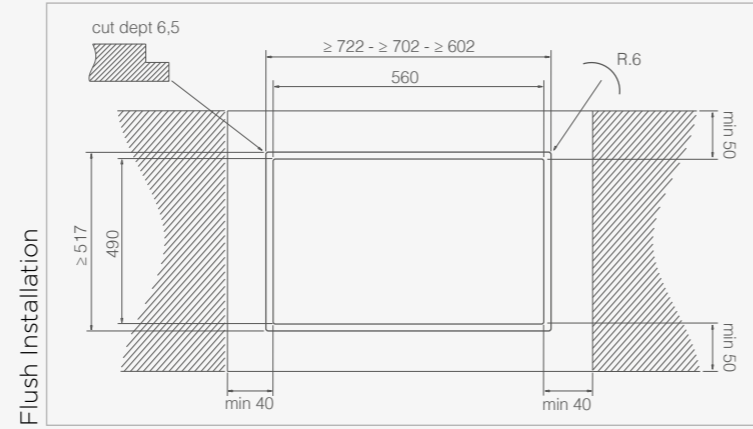
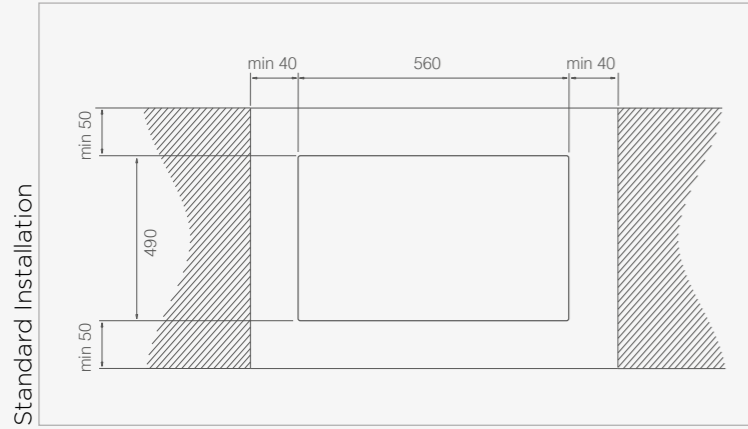

NIKOLATESLA FIT XL - PRIME S

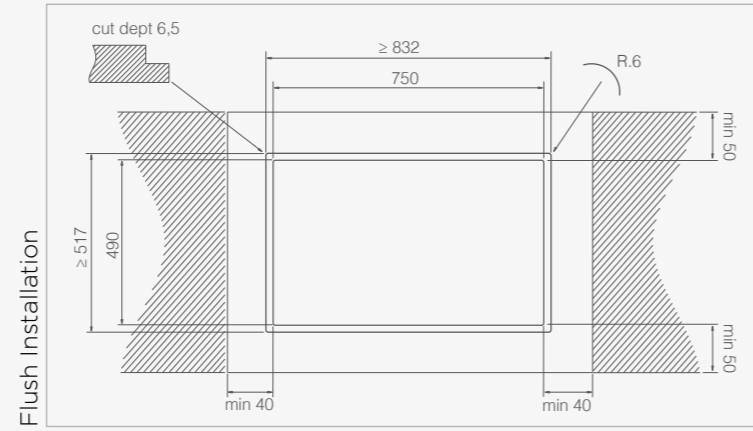
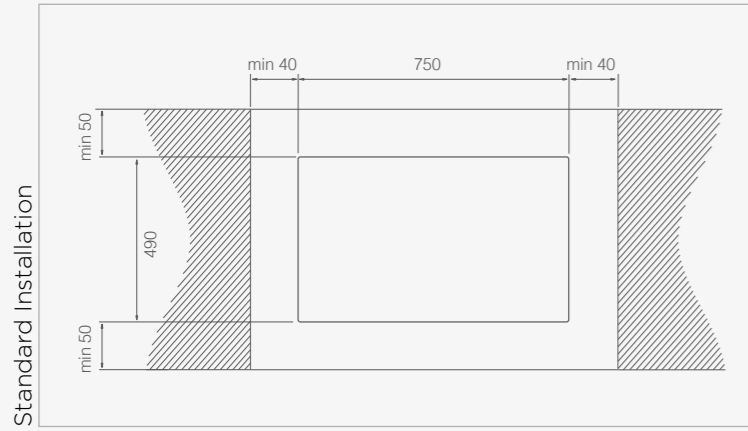

NIKOLATESLA FLAME

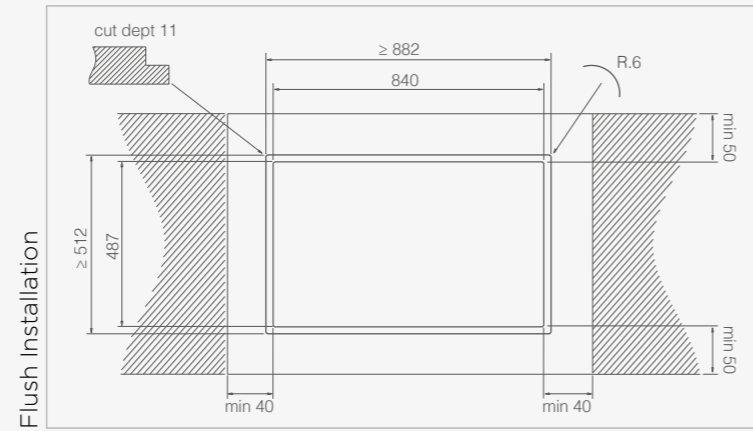
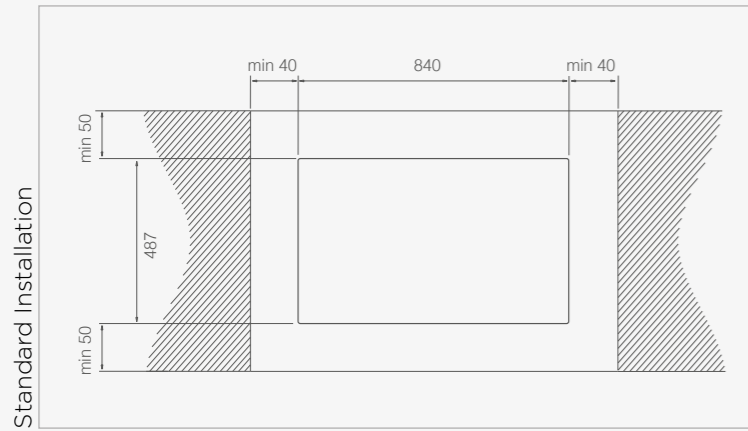

NIKOLATESLA ONE - ONE HP

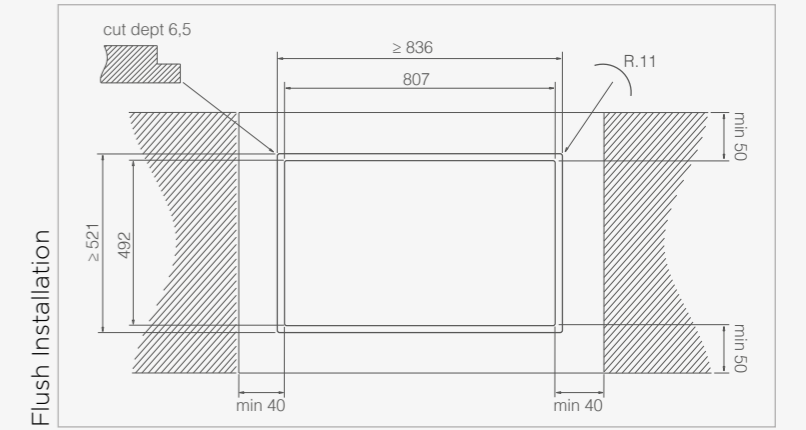
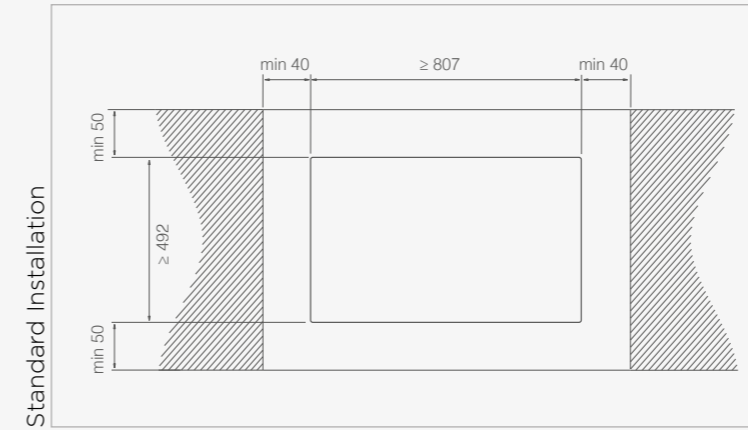

NIKOLATESLA SWITCH - SWITCH GLOW - LIBRA

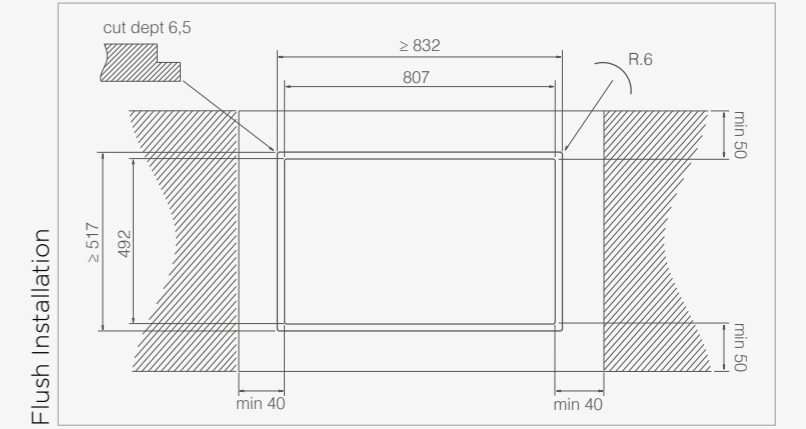
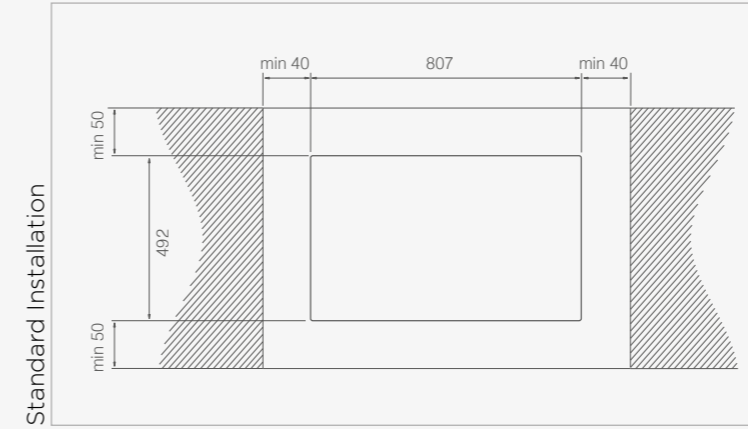

NIKOLATESLA UNPLUGGED

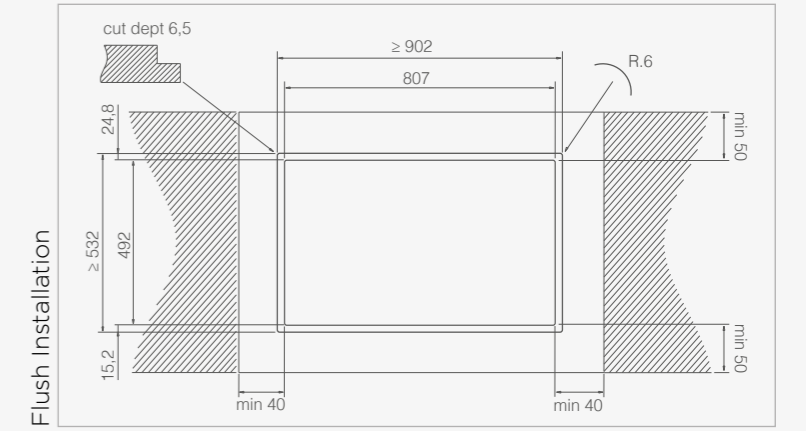
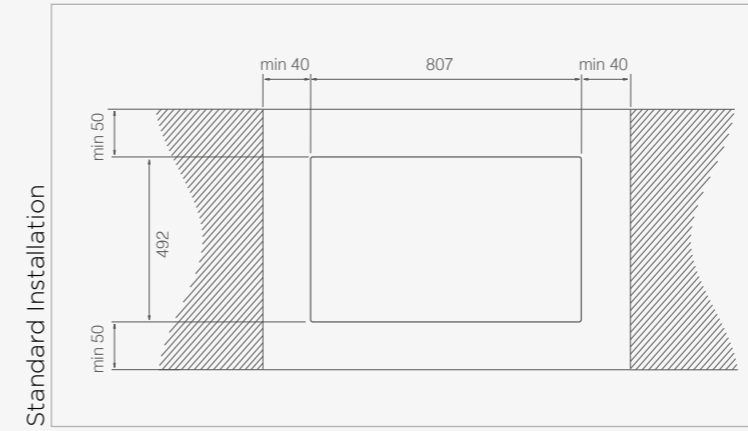

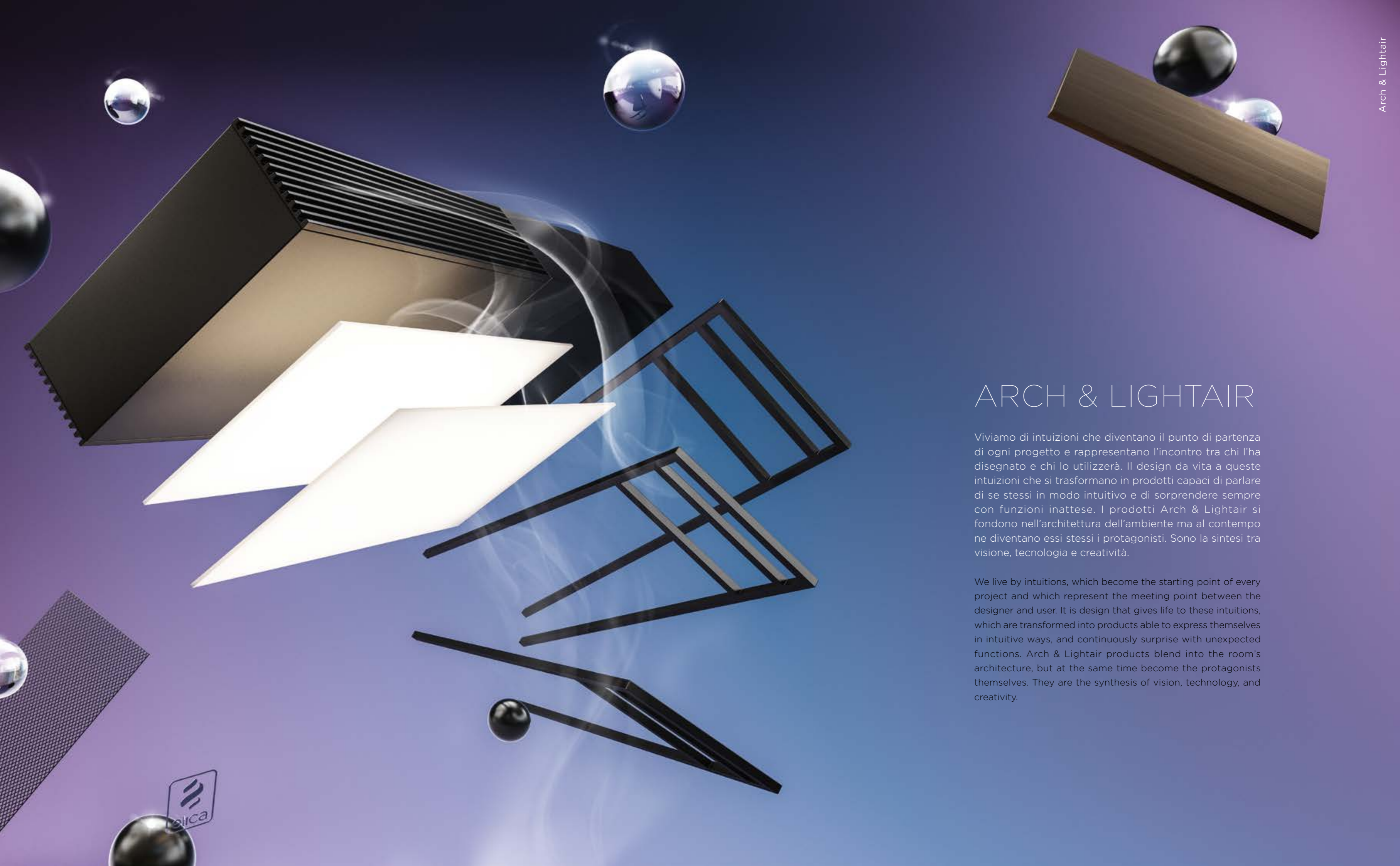

ARCH & LIGHTAIR

Viviamo di intuizioni che diventano il punto di partenza di ogni progetto e rappresentano l'incontro tra chi l'ha disegnato e chi lo utilizzerà. Il design da vita a queste intuizioni che si trasformano in prodotti capaci di parlare di se stessi in modo intuitivo e di sorprendere sempre con funzioni inattese. I prodotti Arch & Lightair si fondono nell'architettura dell'ambiente ma al contempo ne diventano essi stessi i protagonisti. Sono la sintesi tra visione, tecnologia e creatività.

We live by intuitions, which become the starting point of every project and which represent the meeting point between the designer and user. It is design that gives life to these intuitions, which are transformed into products able to express themselves in intuitive ways, and continuously surprise with unexpected functions. Arch & Lightair products blend into the room's architecture, but at the same time become the protagonists themselves. They are the synthesis of vision, technology, and creativity.





OPEN SUITE SUPERIOR

DESIGN FABRIZIO CRISÀ

OPEN SUITE SUPERIOR

DESIGN FABRIZIO CRISÀ





OPEN SUITE SUPERIOR

DESIGN FABRIZIO CRISÀ **ELICA CONNECT**



80x424 - 160x424 cm
 Filtrante Filtering
 Nero effetto soft touch Black soft touch effect



Modello personalizzabile con l'utilizzo di componenti aggiuntivi acquistabili come accessori (mensole, moduli aspiranti e moduli di illuminazione). Customizable model through the use of optional accessories to be purchased separately, such as shelves, extraction and lighting units.

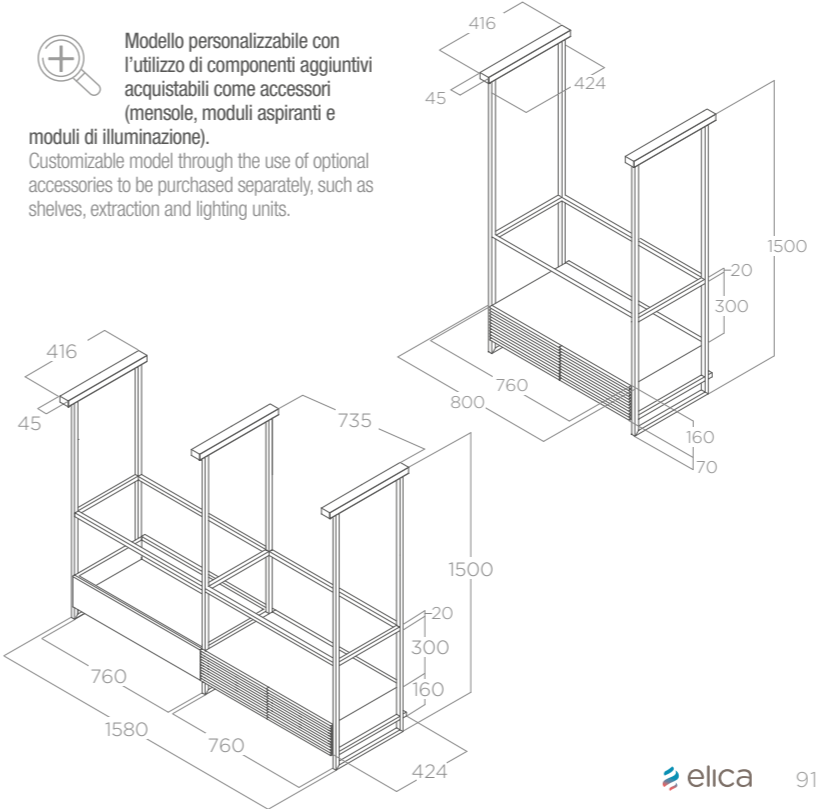

ILLUMINAZIONE LIGHTING

Tipo Type	Led Panel 1x20W (80cm) - 2x20W (160cm)
Intensità Intensity	242 LUX (80cm) - 324 LUX (160cm)
Temperatura Temperature	2700K - 5200K

PERFORMANCE PERFORMANCE

Comandi Controls	Pulsantiera elettronica 3V+2I 3S+2B Electronic push button
Portata intensiva Booster airflow	500 m³/h
Livello sonoro min-max Noise level min-max	63 - 69 db(A)
Assorbimento totale Total absorption	261 W (80cm) - 282 W (160cm)

Filtro grassi alluminio incluso Grease aluminium filter included
 Filtro carbone rigenerabile incluso Regenerable charcoal filter included

ACCESSORI ACCESSORIES

Filtro carbone rigenerabile 2 pezzi 2 pieces Regenerable charcoal filter	KIT0166765
Kit modulo aspirante Superior Extraction module kit Superior	KIT0167079
Kit modulo full Led Superior Full LED module kit Superior	KIT0166961
Kit mensola vetro extra-chiaro Extra-clear glass shelf kit	KIT0166455
Kit mensola vetro fumé Smoked glass shelf kit	KIT0166463
Kit mensola metallo nero Black metal shelf kit	KIT0166470
Kit mensola rete metallica Wire mesh shelf kit	KIT0166472
Kit mensola legno Wooden shelf kit	KIT0166475
Kit traliccio Superior Trellis expansion kit Superior	KIT0166962
Kit cornice mensola Shelf frame kit	KIT0166768

MODELLI MODELS

OPEN SUITE SUPERIOR BL/F/80	PRF0165965
OPEN SUITE SUPERIOR BL/F/160	PRF0166771

Modello non soggetto a certificazione energetica obbligatoria. Model not subject to compulsory energy certification.



OPEN SUITE
DESIGN FABRIZIO CRISÀ

OPEN SUITE

DESIGN FABRIZIO CRISÀ





OPEN SUITE

ELICA CONNECT

DESIGN FABRIZIO CRISÀ



80 - 160 cm
 Filtrante Filtering
 Nero effetto soft touch Black soft touch effect

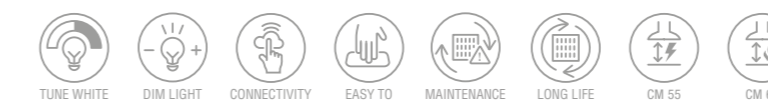

Modello personalizzabile con l'utilizzo di componenti aggiuntivi acquistabili come accessori (mensole, moduli aspiranti e moduli di illuminazione).
 Customizable model through the use of optional accessories to be purchased separately, such as shelves, extraction and lighting units.

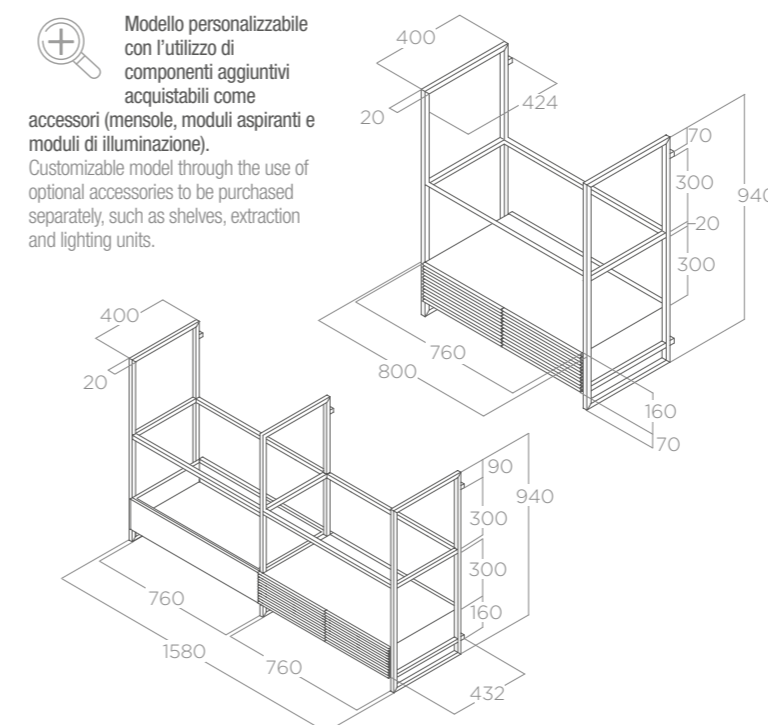

ILLUMINAZIONE LIGHTING

Tipo Type	Led Panel 1x20W (80cm) - 2x20W (160cm)
Intensità Intensity	242 LUX (80cm) - 324 LUX (160cm)
Temperatura Temperature	2700K - 5200K

PERFORMANCE PERFORMANCE

Comandi Controls	Pulsantiera elettronica 3V+2I 3S+2B Electronic push button
Portata intensiva Booster airflow	500 m³/h
Livello sonoro min-max Noise level min-max	63 - 69 db(A)
Assorbimento totale Total absorption	261 W (80cm) - 282 W (160cm)

Filtro grassi alluminio incluso Grease aluminium filter included
 Filtro carbone rigenerabile incluso Regenerable charcoal filter included

ACCESSORI ACCESSORIES

Filtro carbone rigenerabile 2 pezzi 2 pieces Regenerable charcoal filter	KIT0166765
Kit modulo aspirante Extraction module kit	KIT0167073
Kit modulo full Led Full LED module kit	KIT0166964
Kit mensola vetro extra-chiaro Extra-clear glass shelf kit	KIT0166455
Kit mensola vetro fumé Smoked glass shelf kit	KIT0166463
Kit mensola metallo nero Black metal shelf kit	KIT0166470
Kit mensola rete metallica Wire mesh shelf kit	KIT0166472
Kit mensola legno Wooden shelf kit	KIT0166475
Kit traliccio Trellis expansion kit	KIT0166963
Kit cornice mensola Shelf frame kit	KIT0166768

MODELLI MODELS

OPEN SUITE BL/F/80	PRF0166703
OPEN SUITE BL/F/160	PRF0167007

Modello non soggetto a certificazione energetica obbligatoria.
 Model not subject to compulsory energy certification.

Arredare gli spazi polifunzionali Furnishing multi-functional spaces

Innovazione è intuire il cambiamento ed immaginare il domani con idee e soluzioni che migliorino l'esperienza di vita delle persone. Open Suite è un prodotto unico, capace di occupare lo spazio in modo nuovo ed inaspettato e di offrire funzionalità inedite. La cappa aspirante diventa parte di un sistema fatto di elementi che interagiscono tra loro e si uniscono dando vita a infinite soluzioni di arredo dove la luce è protagonista.

Innovation is sensing change and imagining tomorrow with ideas and solutions that improve people's experience of life. Open Suite is a unique product, capable of occupying space in a new, unexpected way and of offering previously unseen functionality. The extractor hood becomes part of a system made up of elements that interact and, together, offer infinite furnishing solutions in which light is the star.



Forme, materiali e luce in una innovativa soluzione modulare Shapes, materials, and light in an innovative, modular solution



Nei contesti in cui l'arredamento della zona living gioca un ruolo essenziale, Open Suite è l'alleata perfetta. La sua struttura modulare, personalizzabile, dallo stile unico è immediatamente riconoscibile e dona carattere all'ambiente. I tralci sono verniciati in nero soft touch e la bocca di aspirazione è arricchita da griglie effetto ghisa.

In settings in which the furniture in the living area plays an essential role, Open Suite is the perfect ally. Its modular, customisable structure, with a unique style, is immediately recognisable and adds character to the environment. The latticework is painted in soft touch black and the extractor opening features cast iron effect grids.

DESIGN MODULARE

Open Suite racchiude in sé più funzioni: non solo cappa ma anche luce e una vasta scelta di ripiani da arredo. Si parte da quattro configurazioni preimpostate (isola 80 e 160cm, parete 80 e 160cm) che possono essere sia una soluzione completa, sia la base da cui partire per aggiungere complementi. L'ampia scelta di elementi e finiture disponibili include ripiani in vetro (chiaro e smoke), metallo e rete metallica neri, legno (noce o personalizzabile), ma anche moduli aspiranti e pannelli luminosi aggiuntivi per aumentare la potenza aspirante o espandere il punto luce sul piano di lavoro. Nella versione a isola, l'altezza della struttura è regolabile per consentire l'installazione all'interno di ogni ambiente, indipendentemente dalla misura del soffitto. Realizza la tua versione unica di Open Suite giocando con gli spazi e ricreando linee e geometrie in base ai tuoi gusti personali e allo stile dell'arredamento.

MODULAR DESIGN

Open Suite offers several functions: not only a hood but also light and a wide choice of shelves. It comes with four pre-set configurations (island 80cm and 160cm, wall 80cm and 160cm) that can be both a complete solution and the base from which to add accessories. The wide choice of available elements and finishings include glass shelves (clear and smoke), black metal and metallic mesh, wood (walnut or customisable), but also extractor modules and additional light panels to increase the extraction power or expand the light point across the work surface. In the island version, the height of the structure is adjustable to allow installation inside any environment, regardless of the height of the ceiling. Create your own unique version of Open Suite by playing with spaces and recreating lines and geometries according to your personal taste and the style of your furniture.

Luce funzionale ed emozionale, un autentico elemento di arredo Functional and evocative light, a genuine piece of furniture

La luce è uno dei caratteri distintivi di Open Suite: mentre la nuova soluzione di installazione elimina efficacemente e silenziosamente tutti gli odori dall'ambiente, il grande pannello led, potente ed efficiente, assicura un'illuminazione uniforme, adattabile in intensità e in temperatura di colore. Così Open Suite diventa un punto luce strategico durante la preparazione dei cibi ma anche una luce ambiente di grande atmosfera durante i momenti più conviviali, sempre in perfetta armonia con lo spazio circostante.

La superficie illuminante è massima e perfettamente ottimizzata, sia nella soluzione base da 80cm che in quelle più estese equipaggiate con pannelli full led aggiuntivi.

Light is one of the distinctive features of Open Suite: whilst the new installation solution effectively and silently eliminates smells from the environment, the large LED panel, powerful and efficient, ensures uniform lighting, that can be adjusted in intensity and colour temperature. This is how Open Suite becomes a strategic light point when preparing food, but also ambient lighting creating a great atmosphere for any occasion, always in perfect harmony with the surrounding space. The illuminating surface is maximised and perfectly optimised, both in the base 80cm solution and in the larger solutions equipped with additional LED panels.



Connessione Wi-Fi Wifi connection

Disegnata per garantire la massima libertà di movimento in cucina, oltre ai comandi ergonomici collocati frontalmente, Open Suite fa parte della linea di cappe intelligenti Elica Connect. Tramite il controllo vocale o la app Elica Connect è possibile accendere o spegnere il prodotto, regolarne la potenza di aspirazione e modulare l'intensità della luce. La App consente inoltre di monitorare lo stato di efficienza dei filtri e di richiedere qualsiasi tipo di assistenza con pochi click.

Designed to ensure the greatest freedom of movement in the kitchen, in addition to the front-positioned ergonomic controls, Open Suite is part of the line of Elica Connect intelligent hoods. Using voice commands or the Elica Connect app, you can turn the product on and off, adjust its extraction power, and modulate the intensity of the light. The App also lets you monitor the efficiency of the filters and to seek any sort of assistance with just a few clicks.

ELICA CONNECT

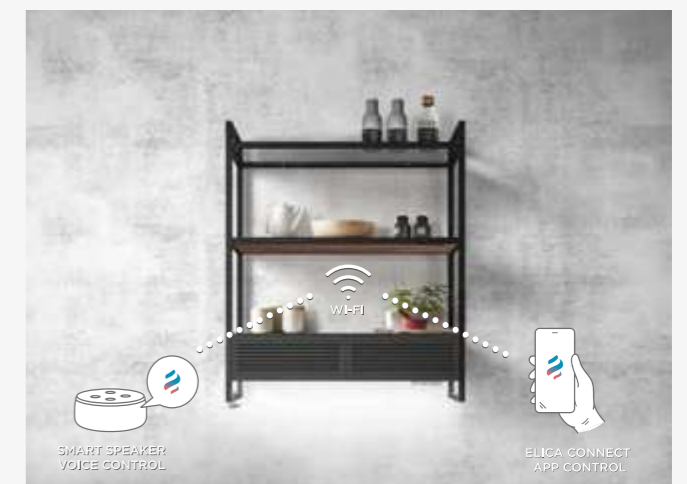

Crea la cappa adatta al tuo stile Create the hood that best fits your style

Grazie agli accessori a disposizione, potete realizzare infinite composizioni in base all'architettura del vostro ambiente e alle vostre necessità, partendo dalle due versioni base ordinabili a catalogo.

OPEN SUITE SUPERIOR (VERSIONE A ISOLA) OPEN SUITE SUPERIOR (ISLAND VERSION)



OPEN SUITE SUPERIOR BL/F/80 PRF0165965
Modulo cappa + 1 mensola in vetro chiaro (80cm)
Hood module + 1 shelf in clear glass (80cm)



OPEN SUITE SUPERIOR BL/F/160 PRF0166771
1 modulo cappa + 1 modulo luce + 2 mensole in vetro chiaro (160cm)
1 hood module + 1 light module + 2 shelves in clear glass(160cm)

OPEN SUITE (VERSIONE A PARETE) OPEN SUITE (WALL VERSION)



OPEN SUITE BL/F/80 PRF0166703
Modulo cappa + 1 mensola in vetro chiaro (80cm)
Hood module + 1 shelf in clear glass (80cm)



OPEN SUITE BL/F/160 PRF0167007
1 modulo cappa + 1 modulo luce + 2 mensole in vetro chiaro (160cm)
1 hood module + 1 light module + 2 shelves in clear glass(160cm)

Thanks to the available accessories, you can create an unlimited number of arrangements based on the structure of your environment and your needs, starting with the two base versions that can be ordered in the catalogue.

In che modo How



Sia per la versione a isola che a parete, partendo dai due prodotti base, puoi scegliere di personalizzare la tua Open Suite in altezza, aggiungendo o sostituendo i ripiani.

Both for the island version and the wall version, starting from the two base products, you can choose to customise the height of your Open Suite, adding or replacing shelves.



Puoi comporre la Open Suite più adatta al tuo ambiente muovendoti anche in larghezza, aggiungendo, tramite tralicci di collegamento, moduli cappa, moduli luce o mensole.

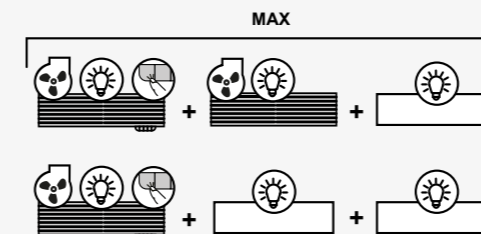
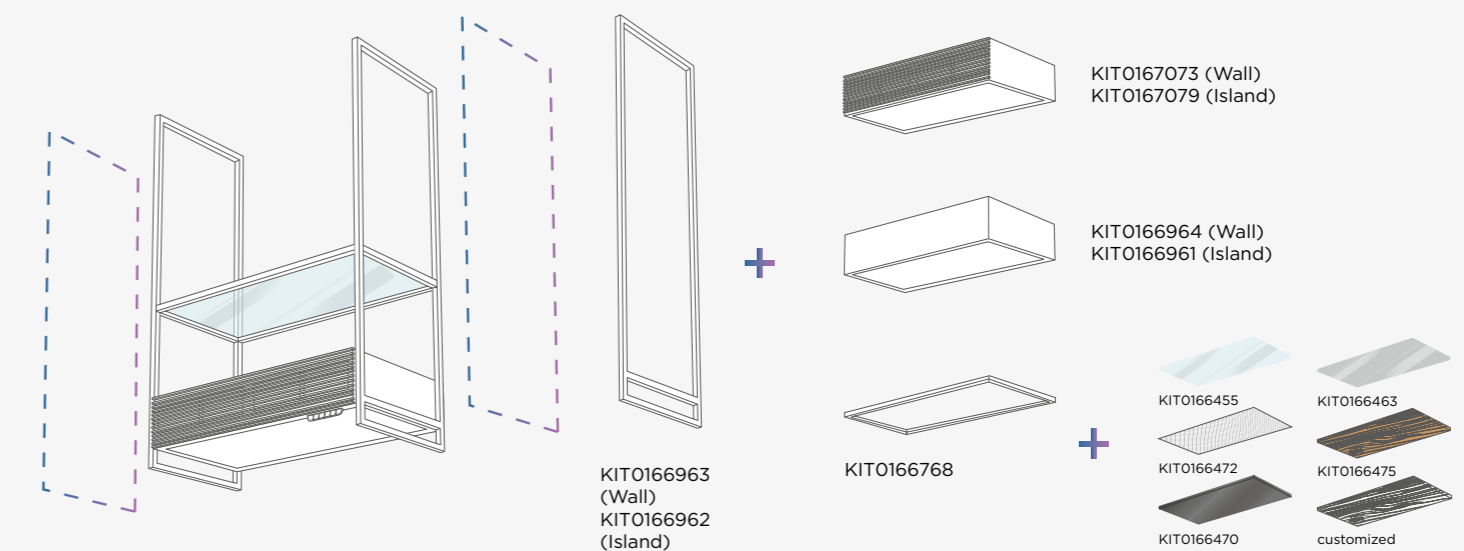
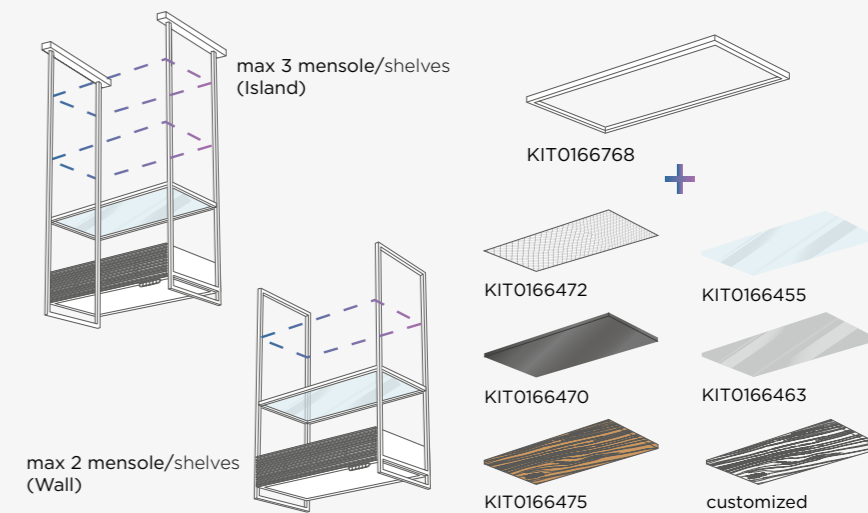

Sia per la versione a parete che per quella ad isola, è possibile collegare elettricamente fino ad un massimo di 3 moduli secondo la tipologia e l'ordine descritto nello schema qui a fianco. Non c'è un limite massimo per il montaggio di mensole accessorie di ogni tipologia.

For both the wall and island versions, it is possible to electrically connect up to a max of 3 units according to the type and order illustrated in the diagram here to the side. There is no maximum limit on the installation of shelves and accessories of any type.

ALCUNE IDEE DI COMPOSIZIONE PER SOLUZIONI A ISOLA SOME ARRANGEMENT IDEAS FOR ISLAND SOLUTIONS



ALCUNE IDEE DI COMPOSIZIONE PER SOLUZIONI A PARETE SOME ARRANGEMENT IDEAS FOR WALL SOLUTIONS

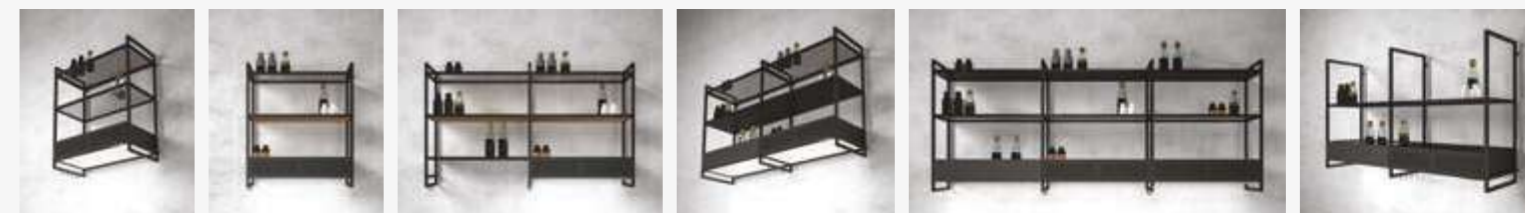

Con che cosa With what

Elica ti mette a disposizione una gamma completa di accessori strutturali ed estetici per rendere la tua cappa più in linea con il tuo stile e la tua cucina. Si possono abbinare tra di loro e vengono venduti separatamente da ciò che si trova nel kit base nella scatola.

Elica offers a complete line of structural and aesthetic accessories to best match your hood with your kitchen style. They can be combined with each other, and are sold separately from what is found in the basic accessory kit.

Mensole di arredo Decorative Shelving

Mensole dal design moderno in vetro, metallo, rete metallica e legno combinabili tra loro. Rendono la tua composizione unica e regalano molto spazio in più dove poter riporre oggetti.

Modern design shelves in glass, metal, metal mesh and wood, all mix and matchable. Making your composition unique, while granting much useable space for storing objects.



KIT0166455
Kit mensola vetro extra-chiaro
Extra-clear glass shelf kit



KIT0166463
Kit mensola vetro fumé
Smoked glass shelf kit

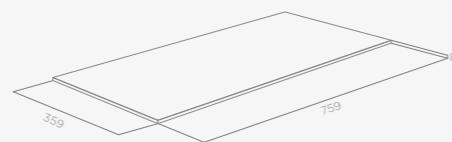

KIT0166470
Kit mensola metallo nero
Black metal shelf kit



KIT0166472
Kit mensola rete metallica
Wire mesh shelf kit



KIT0166475
Kit mensola legno
Wooden shelf kit

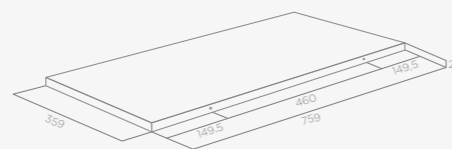
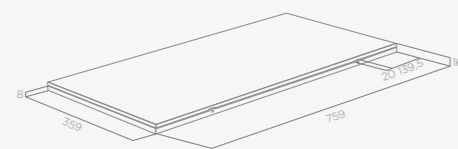
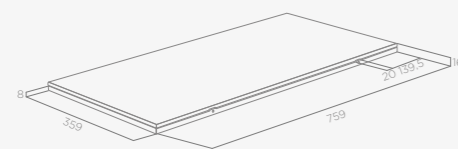

Filtro Carbone Rigenerabile Regenerable charcoal filter

Filtro Odori con livello di efficienza di filtraggio che si aggira tra il 40-60% capace di rigenerarsi e di durare fino ad un massimo di 3 anni rispetto a filtri standard. Per mantenere tali caratteristiche, il filtro deve essere lavato ogni 2 o 3 mesi con acqua calda e detergente delicato o nella lavastoviglie a 65°C. e poi asciugato in forno per 10 minuti a 100°.

Odour filter with filtering efficiency that ranges from 40-60%. Capable of regenerating itself and of lasting up to a maximum of 3 years in comparison to standard filters. To maintain such characteristics, the filter must be washed every 2 or 3 months with hot water and mild soap, or in the dishwasher at 65°C. and can be dried in the oven for 10 minutes at 100°.



KIT0166765
Filtro carbone rigenerabile incluso
Regenerable charcoal filter included

Modulo aspirante Extraction unit

Dedicato a coloro a cui piace sperimentare in cucina, È possibile aggiungere ad Open Suite più moduli aspiranti, aumentando la sua capacità di aspirazione, in base alle proprie esigenze, per una più efficace eliminazione degli odori.

For any who loves experimenting in the kitchen, multiple extraction units may be added to Open Suite, thus increasing extraction capacity, according to need, for more effective odor removal.

KIT0167079
Kit modulo aspirante Superior
Extraction module kit Superior

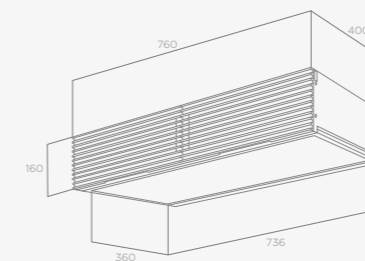

KIT0167073
Kit modulo aspirante
Extraction module kit

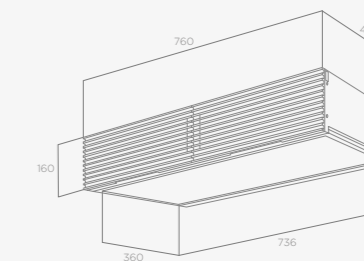

Moduli luce Lighting units

I moduli aggiuntivi con luce full led sono indicati per chi cerca un piano di lavoro sempre ben illuminato. Inoltre, la parte superiore del modulo è pensata per contenere e tenere a portata di mano gli utensili da cucina di uso quotidiano.

Additional units with full LED lighting are best for anyone who likes a well-lit worktop. Furthermore, the upper part of the unit has been designed to keep everyday kitchen utensils handy.

KIT0166961
Kit modulo full Led Superior
Full LED module kit Superior

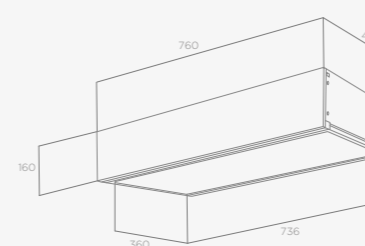

KIT0166964
Kit modulo full Led
Full LED module kit

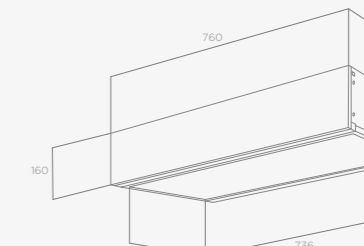

Accessori strutturali Structural accessories

Per ampliare la propria Open Suite, sia verticalmente che orizzontalmente, sono necessari alcuni accessori per fissare la struttura del prodotto nel miglior modo possibile, a garanzia di un montaggio sicuro e funzionale.

To make your Open Suite bigger, both vertically and horizontally, some accessories are required to fix the structure of the product in the best possible way, in order to guarantee safe and functional assembly.

KIT0166962
Kit traliccio Superior
Trellis expansion kit Superior

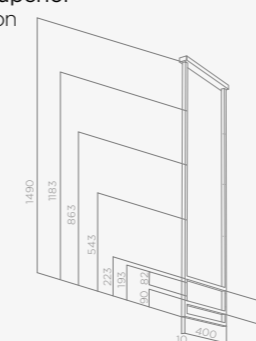

KIT0166963
Kit traliccio
Trellis expansion kit

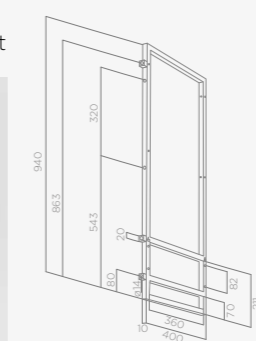

KIT0166768
Kit cornice mensola
Shelf frame kit

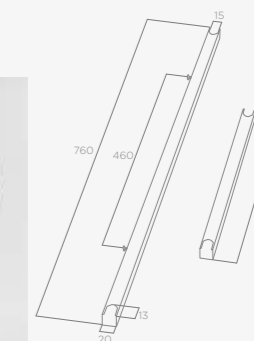



IKONA MAXXI PURE
DESIGN FABRIZIO CRISÀ



IKONA MAXXI PURE

DESIGN FABRIZIO CRISÀ



IKONA MAXXI PURE

DESIGN FABRIZIO CRISÀ ELICA AIR PURE

120 x 44 cm
 Filtrante Filtering
 Acciaio inox, nero effetto soft touch Stainless steel, black soft touch effect

ILLUMINAZIONE LIGHTING

Tipo Type	Strip Led 1x7 W
Intensità Intensity	365 LUX
Temperatura Temperature	3500 K

PERFORMANCE ASPIRAZIONE (MOTORE 1) EXTRACTION PERFORMANCE (MOTOR 1)

Comandi Controls	Touch control capacitivo 3V+I 3S+B Capacitive touch control
Portata intensiva Booster airflow	600 m ³ /h
Livello sonoro min-max Noise level min-max	47 - 62 db(A)
Assorbimento totale Total absorption	207 W

Filtro grassi alluminio incluso Grease aluminium filter included
 Filtro carbone rigenerabile incluso Regenerable charcoal filter included
 Filtro Hepa-Carbone incluso Hepa-Charcoal filter included



ACCESSORI ACCESSORIES

Filtro carbone rigenerabile Regenerable charcoal filter	CFC0162221
Filtro Hepa-Carbone Hepa-Charcoal filter	KIT0176157
Kit camino nero Black chimney kit	KIT0175017
Kit camino acciaio inox Stainless steel chimney kit	KIT0175018
Kit installazione a parete acciaio inox Stainless steel wall installation kit	KIT0175807
Kit installazione a parete nero Black wall installation kit	KIT0175808
Kit prolunga cavi (5m) Extension cable kit (5m)	KIT0147942
Kit prolunga cavi (2,5m) Extension cable kit (2,5m)	KIT0147941

DUCT-OUT MIN 790 MAX 1210
 FILTERING MIN 890 MAX 1210

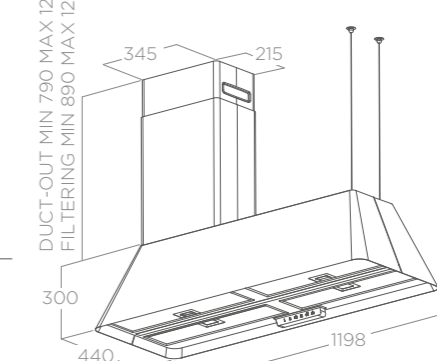

PERFORMANCE PURIFICAZIONE (MOTORE 2) PURIFICATION PERFORMANCE (MOTOR 2)

Comandi Controls	Touch control capacitivo 2V 2S Capacitive touch control
Per stanze fino a For room up to	30 m ²
Livello sonoro min-max Noise level min-max	37 - 66 db(A)
Assorbimento totale Total absorption	175 W
Particelle filtrate Filtered particles	Acari della polvere/polvere, peli di animali, pollini, muffe, fumo di sigaretta, combustibili per stufe, formaldeide (pitture e rivestimenti), odori di cottura. Dust/dust mites, animal dander, pollens, molds, cigarettes smoke, stoves combustibles, formaldehyde (paintings and coating), cooking odors.



MODELLI MODELS

IKONA MAXXI PURE BL MAT/F/120	PRF0171195
IKONA MAXXI PURE IX/F/120	PRF0171196

Il motore della cappa e quello del purificatore sono azionabili con un'interfaccia dedicata e funzionano alternativamente l'uno dall'altro. Il camino, disponibile come accessorio sia per la versione aspirante che per quella filtrante, può essere installato sopra il motore cappa, a destra o a sinistra. Installabile anche a parete ordinando il kit accessorio dedicato. The motor of the hood and purifier can be activated from a dedicated interface and operate alternately to each other. The chimney, available as an accessory for filtering and duct-out versions, can be installed above the hood motor, either on the right or left. It may also be wall-mounted, thanks to the specific accessory kit to be ordered separately.

Il benessere in casa tua: stile e aria pura.
Wellness in your own home: style and pure air.



Oggi la cucina e il living sono uno spazio unico dove viviamo molti momenti della giornata e in cui cerchiamo comfort e benessere attraverso arredi dalle forme armoniose ed eleganti, illuminazione piacevole, nessun rumore fastidioso ma soprattutto aria purificata da respirare. A questo scopo, Elica crea Ikona Maxxi Pure, un valido aiuto per mantenere il giusto equilibrio della qualità dell'aria nella zona living, e che diventerà parte della tua routine quotidiana.

Today, the kitchen and living are a single space where we spend much of our day, in which we seek comfort and wellness through harmonious and elegant furnishings, pleasant lighting, the absence of annoying noises, but above all, the purified air that we breathe. With this in mind, Elica has created Ikona Maxxi Pure, a valuable aid in ensuring the right balance of the air quality in the living area, which will become part of your daily routine.

Un prodotto multifunzione che si prende cura dell'aria indoor
A multifunctional product that looks after indoor air

Ikona Maxxi Pure incorpora, in un elegante oggetto di arredo, una cappa e un purificatore d'aria che si prendono cura due volte dell'aria della casa. È stato pensato per migliorare la qualità dell'aria domestica senza bisogno di installare dispositivi aggiuntivi o sistemi di monitoraggio complessi, spesso scomodi e ingombranti.

Ikona Maxxi Pure è stato progettato per far funzionare in modo indipendente cappa e purificatore, senza alcun compromesso in termini di prestazioni e fruibilità. Il "cuore cappa" di Ikona Maxxi Pure elimina in modo efficace i vapori e gli odori della cottura. In alternativa, azionando il suo purificatore, sarà possibile liberare l'aria della zona giorno da allergeni e inquinanti, fornendo un aiuto concreto nel combattere sintomi allergici e malesseri respiratori legati presenza di agenti chimici, donando una sensazione di salute e di buonumore durante l'intera giornata.



Ikona Maxxi Pure incorporates, in an elegant furnishing, a hood and air purifier that take twofold care of the home's air. It has been designed to improve the quality of domestic air without needing to install additional devices or complex monitoring systems which are often impractical and invasive. Ikona Maxxi Pure has been designed to allow the hood and purifier to operate independently, without compromising on either performance or usability. The "hood core" of Ikona Maxxi Pure efficiently eliminates cooking fumes and vapours. Alternatively, by activating its purifier, the air in the living area can be freed of allergens and pollutants, providing an effective aid in combating allergy symptoms and breathing ailments tied to the presence of chemical agents, offering a sense of well-being and tranquillity all throughout the day.

Purificazione dell'aria super silenziosa
Super-silent air purification



Ikona Maxxi Pure è in grado di purificare completamente l'aria di un ambiente di 30m² in soli 20 minuti. Il purificatore d'aria è dotato di uno speciale filtro combinato HEPA-carbone e può catturare particelle piccole fino a 1 micron. Ha due modalità: "Boost" per una pulizia intensiva dell'aria, e "Super Silent", perfetta per purificare silenziosamente la stanza lavorando in background.

Ikona Maxxi Pure is able to completely purify the air in a 30m² space in just 20 minutes. The air purifier is fitted with a special combined HEPA-carbon filter and can capture particles as small as 1 micron. It has two operating modes: "Boost" for intensive air cleaning, and "Super Silent", perfect for silently purifying the room, working in the background.



COMBO PURE FILTER (HEPA-CARBONE)
COMBO PURE FILTER (HEPA-CARBON)

Lo speciale Combo Pure Filter, un combinato di Hepa e carbone, cattura gli agenti inquinanti liberando la zona living da odori e allergeni come polvere, peli di animali, pollini, muffe e residui dannosi prodotti da detersivi per la pulizia della casa, pitture e rivestimenti. Per mantenere efficace la purificazione dell'aria, il filtro deve essere sostituito circa una volta all'anno. Ikona Maxxi Pure ti ricorderà di cambiarlo tramite un avviso sull'interfaccia utente, a garanzia di respirare sempre aria sana.

The special Combo Pure Filter, a combined Hepa and carbon filter, captures polluting agents, freeing the living area of unpleasant odours and allergens such as dust, animal hair, pollen, mould, and harmful residues produced by household detergents, paints and coverings. To maintain the efficiency of air purification, the filter must be replaced more or less once per year. Ikona Maxxi Pure will remind you to change it through an alert on the user interface to ensure the air you breaths is always healthy.

Il design che si adatta ad ogni living
A design that adapts to any living space



Il design senza tempo di Ikona Maxxi Pure si adatta perfettamente ad ogni ambiente open space. Il prodotto è disponibile nelle finiture soft black matt o inox. Può essere installato in modalità filtrante o aspirante, sospeso o a parete. Il camino estetico, disponibile come accessorio, è posizionabile esclusivamente sopra la cappa a destra oppure a sinistra.

The timeless design of Ikona Maxxi Pure perfectly adapts to any open space area. The product is available in soft black matt or stainless steel finishes. It can be installed in a recirculating or duct-out version, suspended or wall-mounted. The attractive flue, available as an accessory, can be positioned exclusively above the hood on the right or left.



NUAGE
DESIGN FABRIZIO CRISÀ



NUAGE

DESIGN FABRIZIO CRISÀ



75 cm
Filtrante Filtering
Acciaio inox rivestibile con cartongesso (non incluso), acciaio inox + bianco verniciabile Coverable stainless steel finish with drywall (not included), stainless steel + paintable white



ILLUMINAZIONE LIGHTING

Tipo Type	Strip Led 1x7 W
Intensità Intensity	141 LUX
Temperatura Temperature	3500 K

PERFORMANCE PERFORMANCE

Comandi Controls	Rotativo elettronico 3V+I 3S+B Electronic rotative
Portata intensiva Booster airflow	580 m³/h
Livello sonoro min-max Noise level min-max	49 - 62 db(A)
Assorbimento totale Total absorption	227 W

Filtri grassi inox incluso Stainless steel grease filters included
Filtro carbone incluso Charcoal filter included

ACCESSORI ACCESSORIES

Filtro carbone Charcoal filter	CFC0140343
Filtro carbone rigenerabile Regenerable charcoal filter	CFC0162221

MODELLI MODELS

NUAGE DRYWALL/F/75	PRF0096484
NUAGE PAINTABLE/F/75	PRF0098374

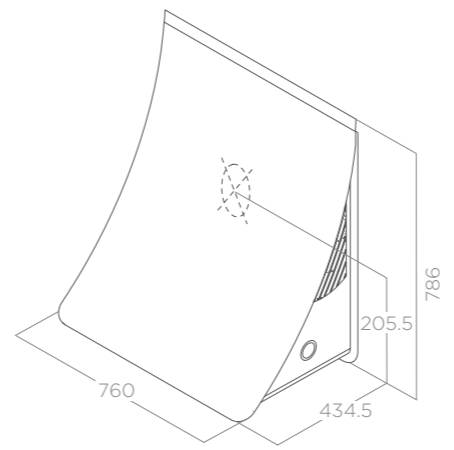

Modello unico e personalizzabile secondo le esigenze del cliente. Due sono le versioni disponibili: rivestibile con cartongesso (spessore di 6 mm, non compreso nella confezione) o metallo bianco verniciabile. Le immagini presentate sono esempi di estetiche esclusivamente dimostrative.
 A unique model that can be personalised to suit customer needs. It is available in two versions: ready for finishing with gypsum panels (6 mm thick, not included in packaging) or in white metal ready for painting. The images shown are only an example of the possible solutions.



YE
DESIGN FABRIZIO CRISÀ





YE

DESIGN FABRIZIO CRISÀ



66x42 cm
Aspirante Duct-out
Cristalplant bianco White cristalplant

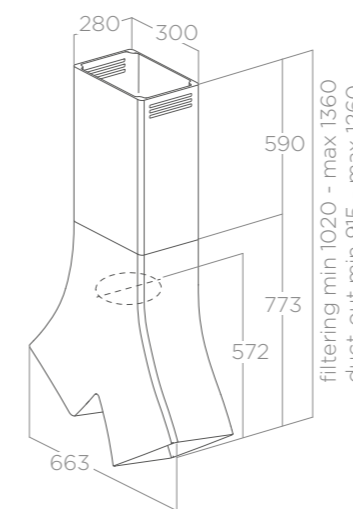

Cristalplant®, materiale ipoallergenico e non tossico, resistente e piacevole al tatto. Grazie alla spugnetta abrasiva inclusa, ogni tipo di 'aggressione' superficiale può essere rimossa, mantenendo inalterato il suo aspetto nel tempo.

Cristalplant®, a hypoallergenic non-toxic material, resistant and agreeable to the touch. Thanks to the abrasive pad, any kind of surface damage can be easily removed while maintaining its original appearance over time.

ILLUMINAZIONE LIGHTING

Tipo Type	Led 2x4 W
Intensità Intensity	609 LUX
Temperatura Temperature	4000 K

PERFORMANCE PERFORMANCE

Comandi Controls	Radiocomando 3V+I 3S+B Remote control
Portata intensiva Booster airflow	700 m ³ /h
Livello sonoro min-max Noise level min-max	50 - 64 db(A)
Assorbimento totale Total absorption	258 W

Filtri grassi inox incluso Stainless steel grease filters included
Radiocomando bianco incluso White remote control included

ACCESSORI ACCESSORIES

Filtro carbone rigenerabile Regenerable charcoal filter	CFC0141737
Radiocomando Design bianco White Design remote control	KIT0121468
Radiocomando Design nero Black Design remote control	KIT0121469

MODELLI MODELS

YE WH/A/66	PRF0098375B
------------	-------------



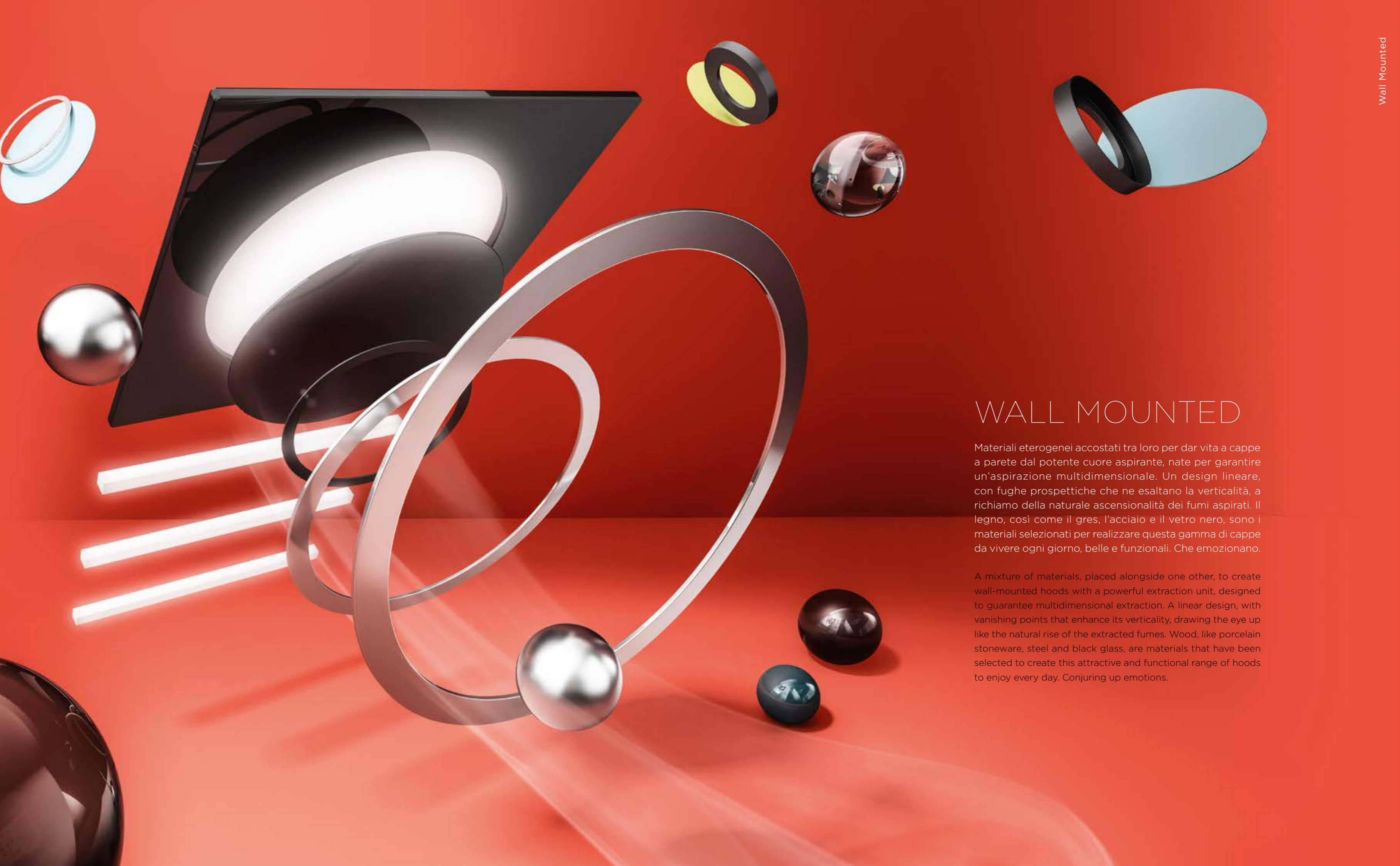

WALL MOUNTED

Materiali eterogenei accostati tra loro per dar vita a cappe a parete dal potente cuore aspirante, nate per garantire un'aspirazione multidimensionale. Un design lineare, con fughe prospettiche che ne esaltano la verticalità, a richiamo della naturale ascensionalità dei fumi aspirati. Il legno, così come il gres, l'acciaio e il vetro nero, sono i materiali selezionati per realizzare questa gamma di cappe da vivere ogni giorno, belle e funzionali. Che emozionano.

A mixture of materials, placed alongside one other, to create wall-mounted hoods with a powerful extraction unit, designed to guarantee multidimensional extraction. A linear design, with vanishing points that enhance its verticality, drawing the eye up like the natural rise of the extracted fumes. Wood, like porcelain stoneware, steel and black glass, are materials that have been selected to create this attractive and functional range of hoods to enjoy every day. Conjuring up emotions.



RULES
DESIGN FABRIZIO CRISÀ



RULES

DESIGN FABRIZIO CRISÀ



RULES DEKTON



RULES

DESIGN FABRIZIO CRISA

60 - 90 - 120 cm

Filtrante Filtering

Vetro nero, Dekton nero "sirius", rivestibile
Black glass, "Sirius" black Dekton, coverable



La versione NAKED di Rules può essere rivestita con un pannello (peso max 10kg) dello stesso materiale utilizzato per le ante del mobile cucina. Le immagini presentate sono solo alcuni esempi di personalizzazioni realizzabili. La forma brevettata dei filtri, in particolare quando la cappa è installata alla minima profondità, facilita la raccolta della condensa che potrebbe formarsi a causa dei vapori di cottura, direzionandola in un apposita vaschetta di raccolta, prevenendo fastidiosi sgocciolamenti sul piano cottura. The NAKED version of Rules can be covered with a panel (max weight 10kg) of the same material used for the cabinet doors. The images show some examples of possible customized versions. The patented shaped filters favor the collection of condensation that may form from cooking vapors, especially when the hood is installed at minimum depth: they convey it into a specific collection tray, thus avoiding bothersome dripping onto the hob.



ILLUMINAZIONE LIGHTING

Tipo Type	STRIP LED 2x7 W (DEKT - NAKED) STRIP LED 1x7 W (BL)
Intensità Intensity	365 (BL) - 310 (DEKT-NAKED) LUX
Temperatura Temperature	3500 K

PERFORMANCE PERFORMANCE

	BL	DEKT / NAKED
Comandi Controls	Touch control capacitivo 3V+I 3S+B Capacitive Touch-control	DEKT / NAKED Pulsantiera elettronica 3V+I 3S+B Electronic push button
Portata intensiva Booster airflow	700 m ³ /h	700 m ³ /h
Livello sonoro min-max Noise level min-max	40 - 58 db(A)	40 - 58 db(A)
Assorbimento totale Total absorption	277 W	280 W

Filtro grassi alluminio incluso Grease aluminium filter included
Filtro carbone rigenerabile incluso Regenerable charcoal filter included

ACCESSORI ACCESSORIES

Filtro carbone rigenerabile (*) Regenerable charcoal filter (*)	CFC0166361
Kit camino inox Stainless steel chimney kit	KIT0171543
Kit camino nero Black chimney kit	KIT0166364
(*) per versione 60 ordinare 2 pezzi (*) for version 60, order 2 pieces (*) per versione 90 ordinare 3 pezzi (*) for version 90, order 3 pieces (*) per versione 120 ordinare 4 pezzi (*) for version 120, order 4 pieces	

MODELLI MODELS

RULES BL/F/60	PRF0163752
RULES BL/F/90	PRF0163751
RULES BL/F/120	PRF0163753
RULES DEKT/F/60	PRF0163755
RULES DEKT/F/90	PRF0163754
RULES DEKT/F/120	PRF0163756
RULES NAKED/F/60	PRF0163758
RULES NAKED/F/90	PRF0163757
RULES NAKED/F/120	PRF0163759



Stand-alone o integrata grazie alla profondità regolabile

Stand-alone or integrated thanks to adjustable depth

Le cucine di oggi, dove linee pulite ed essenziali sono dominanti, richiedono concetti di design flessibili e in grado di massimizzare gli spazi.

Per questo nasce Rules, disegnata per essere in armonia con il progetto cucina. Questo nuovo modello garantisce un'installazione completamente personalizzabile, grazie all'innovativo sistema in grado di modulare millimetricamente la sua profondità in fase di installazione.

Riducendo al minimo lo spessore, 21 cm, Rules diventa stand-alone e quasi scompare nella parete; aumentando la profondità fino a 36 cm si allinea perfettamente a pensili di ogni profondità. Le dimensioni di Rules sono le stesse di pensili standard con altezza di 36 cm e permettono una completa integrazione con tutte le composizioni di cucina.

Today's kitchens, dominated by clean and essential lines, require flexible design concepts able to maximise space. Hence Rules was born, designed to be in harmony with the kitchen project. This new model guarantees a completely customisable solution thanks to the innovative system allowing millimetric modulation of its depth during installation. When reduced to the minimum thickness of 21 cm, Rules becomes a stand-alone and almost disappears into the wall; when the depth is increased to 36 cm, it perfectly aligns with cabinets of any depth. The dimensions of Rules are the same as those of standard cabinets with height 36 cm, allowing complete integration with all kitchen compositions.

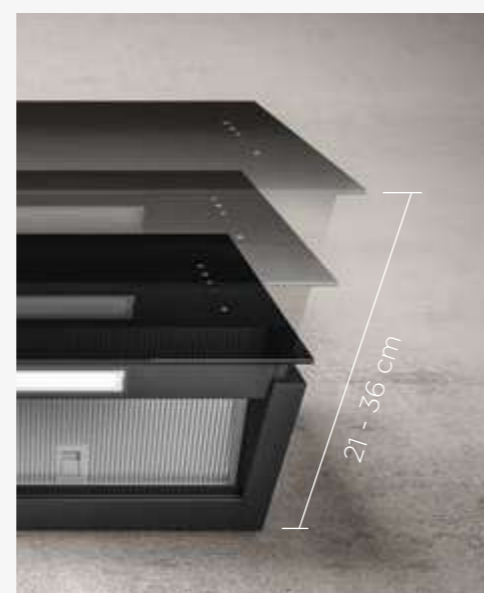

Un vestito su misura

A tailor-made outfit



Ampia è la scelta delle finiture disponibili, studiate per vestire al meglio ogni ambiente.

La versione in vetro nero conferisce al prodotto un design minimal ed elegante. Per chi ricerca invece la totale integrazione con i mobili della propria cucina c'è la versione naked, pannellabile con la stessa anta dei pensili, che permette al prodotto di scomparire, mimetizzandosi perfettamente tra i cabinet.

Per una cappa dal carattere deciso c'è la versione in DEKTON® nero Sirius pensata per ricreare il total look in cucina. Questo materiale è durevole, resistente e di facile manutenzione e conferisce un aspetto sofisticato e moderno ad ogni ambiente.

A broad selection of available finishes, designed to bring out the best in every space.

The version in black glass dresses the product with a minimalist and elegant design. For those looking for total integration with their kitchen furniture there's the naked version, which can be clad with the same door as the cabinets, thus totally concealing and disguising the product among the kitchen cabinets. For a more determined hood there's the version in black DEKTON® Sirius, designed to recreate a total look in the kitchen. A durable, resilient material that's easy to maintain, adding a sophisticated and modern feel to every space.



Facile da pulire

Easy to clean

Rules è dotata di griglie inclinate brevettate che, grazie alla loro speciale struttura, catturano le gocce di condensa e le convogliano all'interno di una vaschetta. Quando è necessaria una pulizia profonda, il collettore dell'acqua può essere rimosso senza la necessità di alcun attrezzo e igienizzato.

La linearità progettuale di Rules la rende estremamente facile da pulire. Tutte le finiture possono essere trattate facilmente con acqua e sapone neutro. Attraverso una semplice rimozione dei filtri antigrasso, è possibile accedere alla parte interna della cappa per la manutenzione dei filtri.

Rules comes with patented tilted grates, which thanks to their special structure, capture drops of condensate and convey them to a collection tray. When deep cleaning is required, the water tray can be removed and sanitised without the need for any tools. The linear design of Rules makes it extremely easy to clean. All the finishes can easily be treated with water and a neutral soap. By simply removing the grease filter, it's possible to reach the inside of the hood to service the filters.



SUPER PLAT
DESIGN FABRIZIO CRISÀ



SUPER PLAT BL



SUPER PLAT GR



SUPER PLAT ELICA CONNECT

DESIGN FABRIZIO CRISÀ



80 cm

Filtrante Filtering

Vetro nero, vetro grigio + effetto ghisa
Black glass, grey glass + cast iron effect

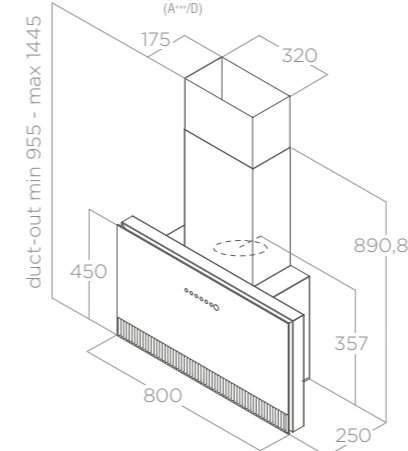
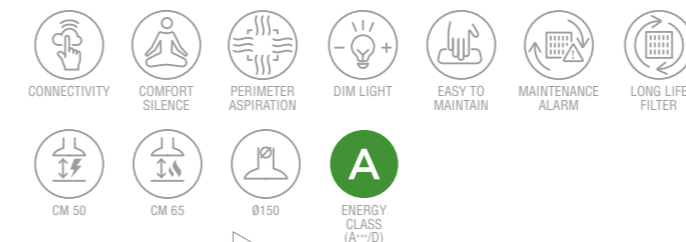

Super Plat consente all'utente di sentirsi più libero e di avere più tempo per concentrarsi sulle operazioni di cottura grazie al suo sistema wireless intelligente. La cappa può essere utilizzata tramite la app Elica Connect o uno smart speaker ricevendo e dando informazioni. Il pannello frontale può essere aperto per aumentare la captazione di tutti i vapori e gli odori anche durante le sessioni di cottura più intense. Super Plat heightens the user's sense of freedom, offering more time to concentrate on cooking thanks to the smart wireless system. The hood can be used either through the Elica Connect app or with a smart speaker, giving and receiving information. The front panel may be opened to increase vapor and odor capture, even during particularly complex cooking sessions.

ILLUMINAZIONE LIGHTING

Tipo Type	Strip Led 1x7 W
Intensità Intensity	197 LUX
Temperatura Temperature	3500 K

PERFORMANCE PERFORMANCE

Comandi Controls	Touch control capacitivo 3V+2I 3S+2B Capacitive touch control
Portata intensiva Booster airflow	740 m ³ /h
Livello sonoro min-max Noise level min-max	37 - 57 db(A)
Assorbimento totale Total absorption	277 W

Filtro grassi alluminio incluso Grease aluminium filter included
Filtro carbone rigenerabile incluso Regenerable charcoal filter included

ACCESSORI ACCESSORIES

Filtro carbone rigenerabile (*) Regenerable charcoal filter (*)	CFC0140423
Kit camino acciaio inox Stainless steel chimney kit	KIT0171543
Kit camino nero Black chimney kit (*) ordinare 3 pezzi (*) order 3 pieces	KIT0166364

MODELLI MODELS

SUPER PLAT BL/F/80	PRF0164980
SUPER PLAT GR/F/80	PRF0165017

Combinazione unica di forme e materiali

Unique combination of form and material

Il nuovo modello Super Plat è una cappa dalle linee semplici e moderne. Nasce dall'esigenza di chi predilige un elettrodomestico che, pur mantenendo la sua identità, si integra perfettamente allo stile della cucina in cui è inserita, senza provocare discontinuità di forma e superficie. Il suo design la rende perfetta sia nell'installazione stand-alone che inserita tra due pensili. Offre un'ampia flessibilità d'uso: nasce in versione filtrante e con l'aggiunta di camini estetici può essere facilmente trasformata in modalità aspirante. Super Plat è disponibile in vetro nero o vetro grigio, combinati con elementi effetto ghisa che la rendono protagonista in cucina.

The new Super Plat model is a hood characterised by simple and modern lines. It's a response to the demand for an electrical appliance, which, despite remaining true to its identity, perfectly blends into the style of the kitchen where it's installed, without interrupting the continuity of forms and surfaces. Its design makes it perfect for installation either as a stand-alone or between cabinets. It offers broad flexibility of use: it is originally a recirculating hood, but with the addition of stylish flues can easily be transformed into a duct-out version. Super Plat is available in black or grey glass, combined with cast iron effect elements to make it a genuine feature item in the kitchen.



Connessione Wi-Fi

Wi-Fi connection ELICA CONNECT

Grazie al suo modulo Wi-fi, Super Plat è sempre connessa ad un cloud a tua disposizione. Attraverso la app Elica Connect si possono controllare da remoto la velocità di aspirazione, tutte le funzionalità della luce e monitorare lo stato del prodotto. Con la app avrai accesso a strumenti che ti aiuteranno a mantenere pulito ed efficiente il tuo prodotto nel tempo. Inoltre, è possibile collegare Super Plat con gli smart speakers più diffusi per comandarla con la tua voce.

Thanks to its Wi-Fi module, Super Plat is always connected to a cloud at your service. Using the Elica Connect app, you can control the extraction speed, all light functions and even monitor the product's status. The app provides you with access to tools that help keep your product running clean and efficiently over time. What's more, Super Plat can be connected with the most popular smart speakers so you can control it with your own voice.

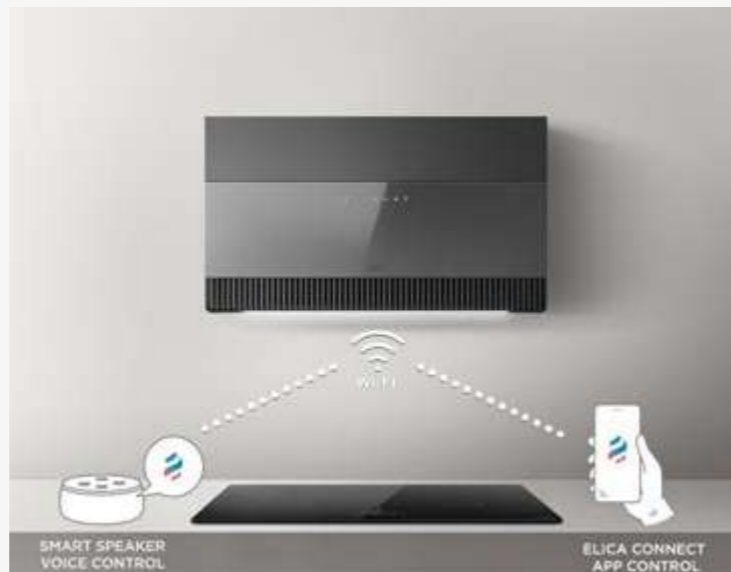

Performance al top

Top performance

Super Plat sfrutta la tecnologia Multi-d Capture di Elica: l'aspirazione non è più concentrata in una specifica zona ma distribuita su tutto il perimetro della superficie frontale. In questo modo la capacità di captazione raggiunge il massimo livello ed è in grado di garantire ottimi risultati nella pulizia dell'aria sia da vapori che da cattivi odori. Nonostante la potenza del suo motore, Super Plat resta molto silenziosa anche alla massima potenza grazie alla tecnologia Comfort Silence che consente una riduzione del rumore durante l'utilizzo della cappa in ogni situazione domestica.

Super Plat exploits Elica's Multi-d Capture technology: extraction is no longer concentrated in one specific zone but rather distributed across the entire perimeter of the front surface. As such, the extraction capacity reaches the highest levels and is able to guarantee excellent results in terms of clearing the air of unpleasant vapours and smells. Despite its powerful motor, Super Plat is extremely quiet even at the highest speed thanks to the Comfort Silence technology, which reduces the noise level during use of the hood in all household situations.



Facile da pulire

Easy to clean

Super Plat è stata progettata per permettere all'utente di eseguire le normali operazioni di manutenzione e pulizia in modo semplice, rapido e sicuro. L'assenza di parti meccaniche a vista per l'apertura del pannello frontale semplifica le operazioni di manutenzione: gli utenti hanno accesso diretto alla parte interna del prodotto e possono muoversi in libertà senza alcun ostacolo. Le griglie sono facilmente smontabili per essere completamente igienizzate.

Super Plat is designed to make standard cleaning and maintenance operations simpler, faster and safer for the user. The absence of any visible mechanical parts when the front panel is opened greatly simplifies maintenance operations: users have direct access to the inside of the product and are free to move without any obstructions. The grates are easy to remove for total sanitisation.





PLAT
DESIGN FABRIZIO CRISÀ



PLAT BL/55



PLAT BL/80



PLAT WH/80



PLAT

DESIGN FABRIZIO CRISÀ

55 - 80 cm
 Filtrante Filtering
 Vetro nero, vetro bianco
 Black glass, white glass

- COMFORT SILENCE
- PERIMETER ASPIRATION
- EASY TO MAINTAIN
- MAINTENANCE ALARM
- LONG LIFE FILTER
- CM 50
- CM 65
- Ø150
- ENERGY CLASS (A++/D)

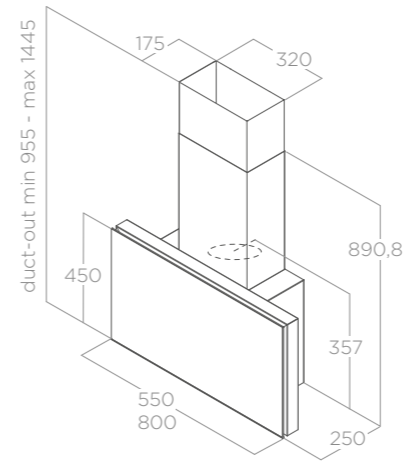

Il pannello frontale può essere aperto per aumentare la captazione di tutti i vapori e gli odori anche durante le sessioni di cottura più intense.
 The front panel may be opened to increase vapor and odor capture, even during particularly complex cooking sessions.

ILLUMINAZIONE LIGHTING

Tipo Type	STRIP LED 1x7 W
Intensità Intensity	365 LUX
Temperatura Temperature	3500 K

PERFORMANCE PERFORMANCE

Comandi Controls	Touch control capacitivo 3V+I 3S+B Capacitive Touch-control
Portata intensiva Booster airflow	710 m³/h
Livello sonoro min-max Noise level min-max	37 - 57 db(A)
Assorbimento totale Total absorption	277 W

Filtro grassi alluminio incluso Grease aluminium filter included
 Filtro carbone rigenerabile incluso Regenerable charcoal filter included

ACCESSORI ACCESSORIES

Filtro carbone rigenerabile (*) Regenerable charcoal filter (*)	CFC0140423
Kit camino inox Stainless steel chimney kit	KIT0171543
Kit camino nero Black chimney kit	KIT0166364
(*) per versione 55 ordinare 2 pezzi (*) for version 55, order 2 pieces	
(*) per versione 80 ordinare 3 pezzi (*) for version 80, order 3 pieces	

MODELLI MODELS

PLAT BL/F/55	PRF0164946
PLAT BL/F/80	PRF0164874
PLAT WH/F/55	PRF0165707
PLAT WH/F/80	PRF0165712



APLOMB BL/90



APLOMB WH/60



APLOMB BL/90



APLOMB BL/60



APLOMB

DESIGN FABRIZIO CRISÀ

60 - 90 cm
Aspirante Duct-out
Vetro nero, vetro bianco
Black glass, white glass

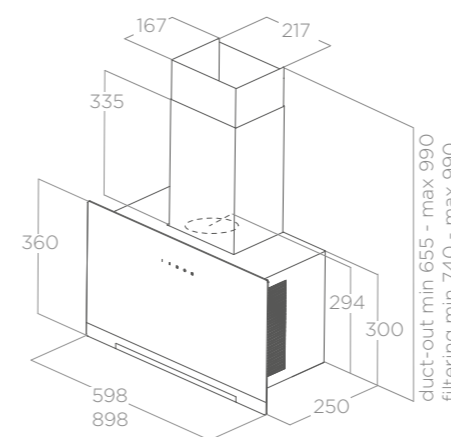

La superficie aspirante della cappa è distribuita su tre zone, direttamente sopra il piano e ai due lati, al fine di garantire una migliore captazione dei fumi.

La cappa, inoltre, è dotata di un sistema di sostegno del pannello frontale che permette di mantenerlo aperto per facilitare la manutenzione ordinaria e straordinaria del prodotto.

The extraction surface of the hood is distributed in three zones, directly over the hob and on the two sides, in order to guarantee top fume capture performance. Furthermore, the hood is equipped with a front panel support system that allows it to remain opened, making regular and special maintenance operations easier.

ILLUMINAZIONE LIGHTING

Tipo Type	STRIP LED 1x3 W
Intensità Intensity	84 LUX
Temperatura Temperature	3500 K

PERFORMANCE PERFORMANCE

Comandi Controls	Touch control capacitivo 3V+I 3S+B Capacitive touch control
Portata intensiva Booster airflow	680 m ³ /h
Livello sonoro min-max Noise level min-max	51 - 64 db(A)
Assorbimento totale Total absorption	233 W

Filtro grassi alluminio incluso Grease aluminium filter included
Camino incluso Chimney included

ACCESSORI ACCESSORIES

Filtro carbone Charcoal filter	CFC0140343
Filtro carbone rigenerabile Regenerable charcoal filter	CFC0162221

MODELLI MODELS

APLOMB BL/A/60	PRF0166938
APLOMB BL/A/90	PRF0166939
APLOMB WH/A/60	PRF0166940
APLOMB WH/A/90	PRF0166941

BLOOM-S

DESIGN FABRIZIO CRISÀ

Wall Mounted





BLOOM-S DEKTON



BLOOM-S DEKTON



BLOOM-S WH



BLOOM-S WH



BLOOM-S

DESIGN FABRIZIO CRISÀ

85 cm

Aspirante Duct-out

Vetro bianco, Dekton nero "sirius"

White glass, "Sirius" black Dekton

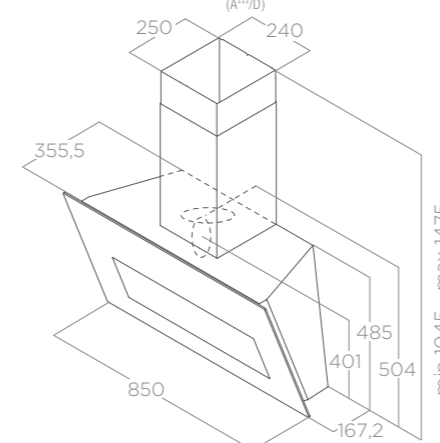
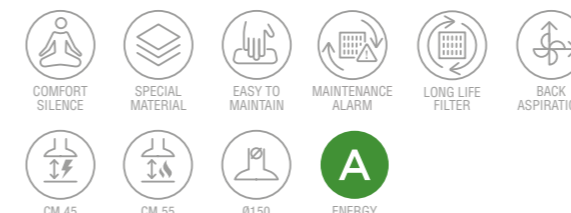

La parte frontale della cappa è caratterizzata da un visore mobile, azionabile manualmente, che consente di aumentare la captazione dei fumi durante le operazioni di cottura. La versione Dekton, grazie alle caratteristiche di questo materiale, ha un'alta resistenza ai raggi UV, ai graffi e alle macchie.

The front part of the hood is characterised by a mobile, manually operated visor, which allows increased fume extraction during cooking. The Dekton version, thanks to the characteristics of this material, is highly resistant to UV rays, scratches and dents.

ILLUMINAZIONE LIGHTING

Tipo Type	STRIP LED 1x7 W
Intensità Intensity	253 LUX
Temperatura Temperature	3000 K

PERFORMANCE PERFORMANCE

Comandi Controls	Touch control infrarossi 3V+2I 3S+2B Infrared touch control
Portata intensiva Booster airflow	750 m ³ /h
Livello sonoro min-max Noise level min-max	35 - 53 db(A)
Assorbimento totale Total absorption	277 W

Filtro grassi alluminio incluso Grease aluminium filter included
Camino incluso Chimney included

ACCESSORI ACCESSORIES

Filtro carbone Charcoal filter	CFC0140343
Filtro carbone rigenerabile Regenerable charcoal filter	CFC0162221

MODELLI MODELS

BLOOM-S WH/A/85	PRF0164490
BLOOM-S DEKT/A/85	PRF0164475

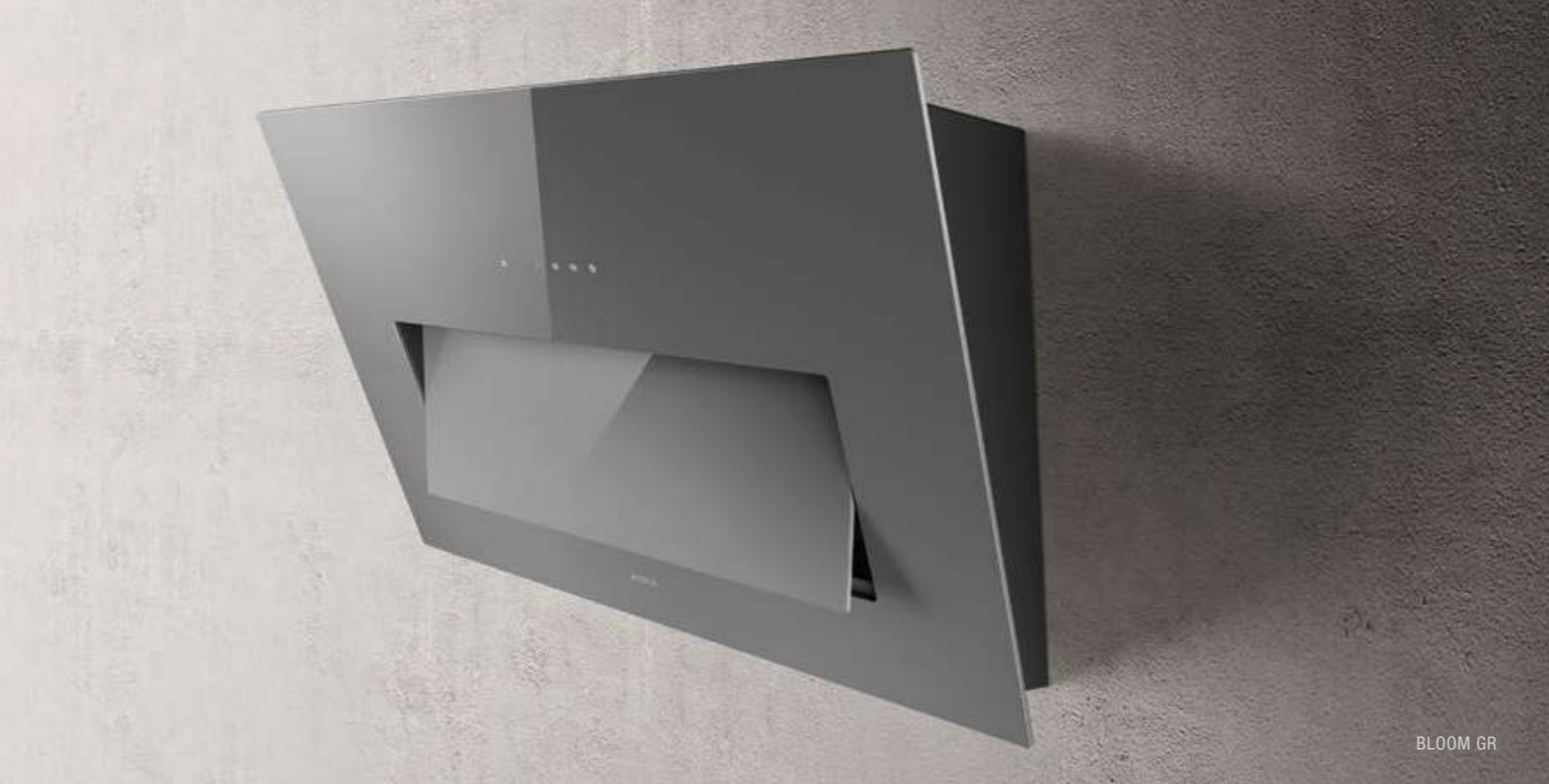

BLOOM GR



BLOOM GR



BLOOM BL



BLOOM BL



BLOOM

DESIGN FABRIZIO CRISÀ

85 cm
Aspirante Duct-out
Vetro nero, vetro grigio
Black glass, grey glass

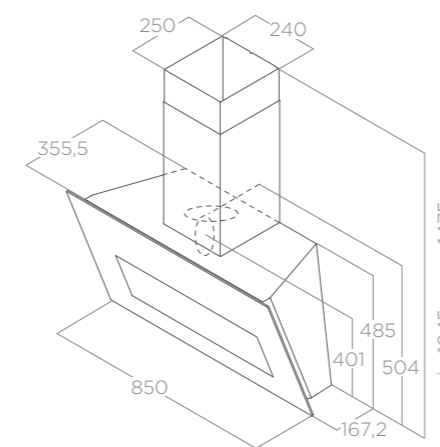
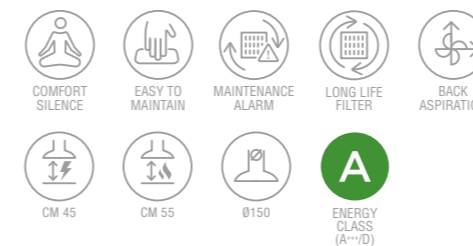

La parte frontale della cappa è caratterizzata da un visore mobile, azionabile manualmente, che consente di aumentare la captazione dei fumi durante le operazioni di cottura. The front part of the hood is characterised by a mobile, manually operated visor, which allows increased fume extraction during cooking.

ILLUMINAZIONE LIGHTING

Tipo Type	STRIP LED 1x7 W
Intensità Intensity	253 LUX
Temperatura Temperature	3000 K

PERFORMANCE PERFORMANCE

Comandi Controls	Touch control capacitivo 3V+I 3S+B Capacitive touch control
Portata intensiva Booster airflow	750 m ³ /h
Livello sonoro min-max Noise level min-max	35 - 56 db(A)
Assorbimento totale Total absorption	277 W

Filtro grassi alluminio incluso Grease aluminium filter included
Camino incluso Chimney included

ACCESSORI ACCESSORIES

Filtro carbone Charcoal filter	CFC0140343
Filtro carbone rigenerabile Regenerable charcoal filter	CFC0162221

MODELLI MODELS

BLOOM BL/A/85	PRF0164459
BLOOM GR/A/85	PRF0164462

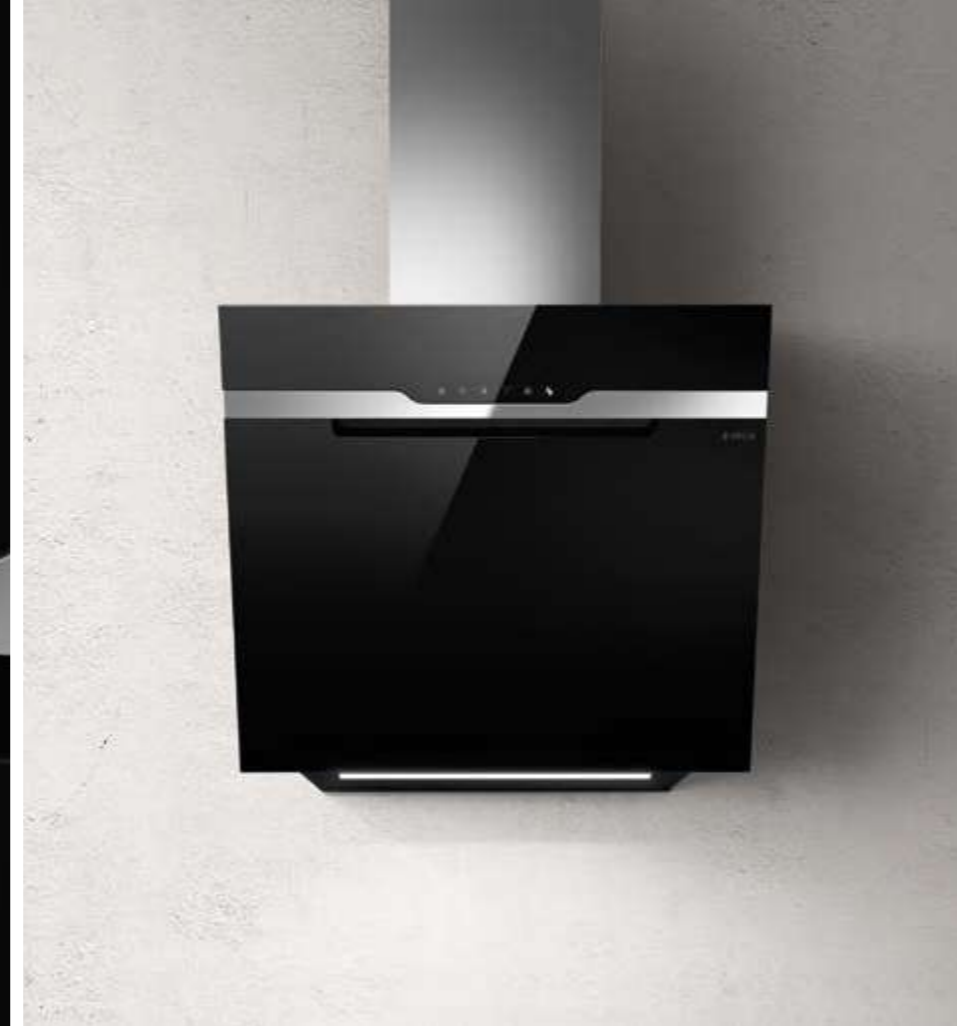

MAJESTIC NO DRIP

DESIGN FABRIZIO CRISÀ

60 - 90 cm
Aspirante Duct-out
Vetro nero + acciaio inox
Black glass + stainless steel

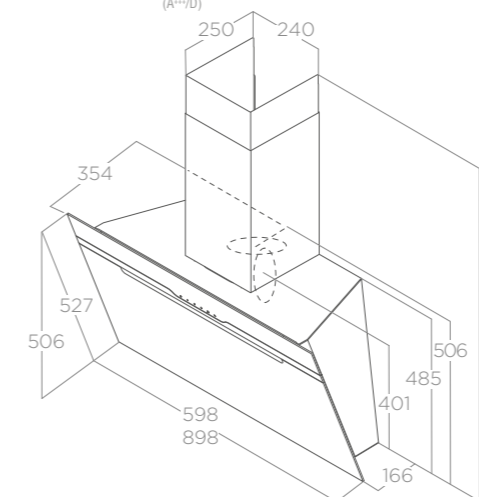
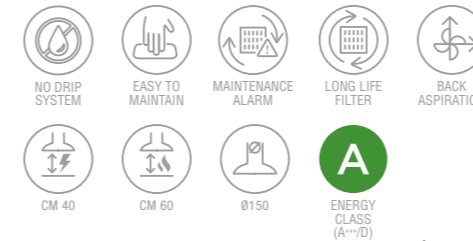

La cappa è dotata di un sistema di resistenze che permette al vetro di riscaldarsi, riducendo così la formazione della condensa. Un suo eventuale residuo viene raccolto in un apposito collettore.
The hood features a heating element system that allows the glass to heat up, thus reducing the formation of condensate. Any residual condensate is then collected in a dedicated manifold.

ILLUMINAZIONE LIGHTING

Tipo Type	Strip Led 1x7 W
Intensità Intensity	253 LUX
Temperatura Temperature	3000 K

PERFORMANCE PERFORMANCE

Comandi Controls	Touch control capacitivo 3V+I 3S+B Capacitive touch control
Portata intensiva Booster airflow	600 m ³ /h
Livello sonoro min-max Noise level min-max	46 - 60 db(A)
Assorbimento totale Total absorption	207 W

Filtro grassi alluminio incluso Grease aluminium filter included
Camino incluso Chimney included

ACCESSORI ACCESSORIES

Filtro carbone Charcoal filter	CFC0140343
Filtro carbone rigenerabile Regenerable charcoal filter	CFC0162221
Radiocomando Design bianco White Design remote control	KIT0121468
Radiocomando Design nero Black Design remote control	KIT0121469

MODELLI MODELS

MAJESTIC NO DRIP BL/A/60	PRF0147731
MAJESTIC NO DRIP BL/A/90	PRF0147732

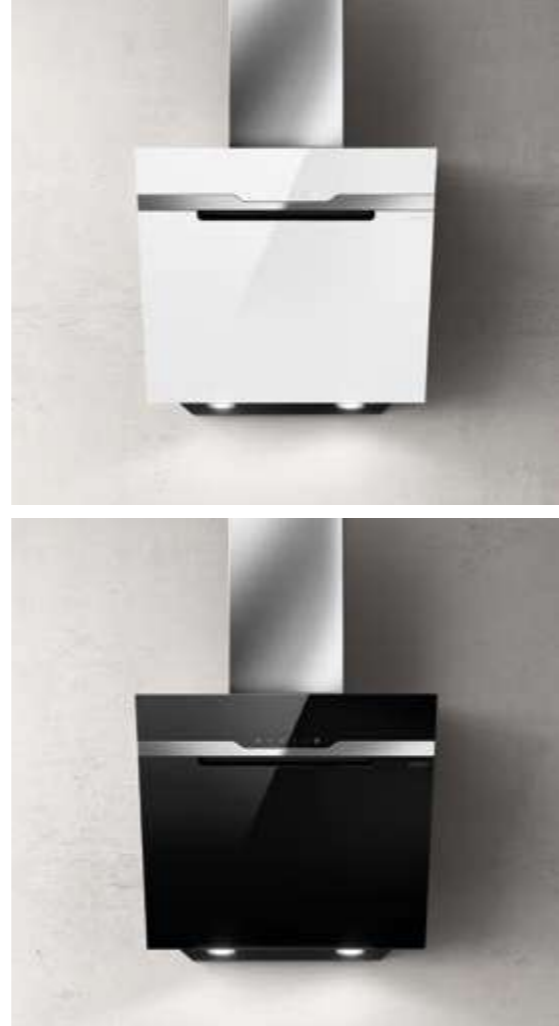

MAJESTIC

DESIGN FABRIZIO CRISA



60 - 90 cm

Aspirante Duct-out

Vetro nero + acciaio inox, vetro bianco + acciaio inox

Black glass + stainless steel, white glass + stainless steel

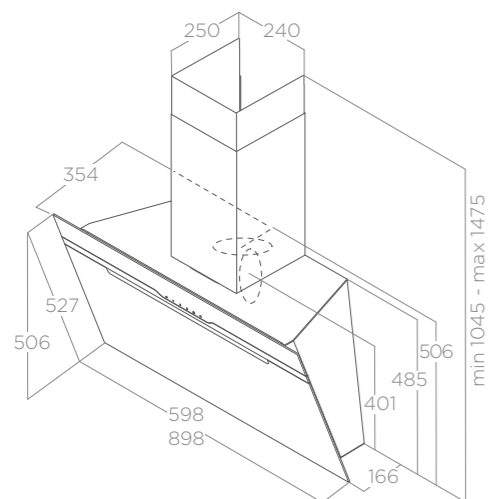

ILLUMINAZIONE LIGHTING

Tipo Type	Led 2x2,5 W
Intensità Intensity	145 LUX
Temperatura Temperature	3000 K

PERFORMANCE PERFORMANCE

Comandi Controls	Touch control capacitivo 3V+I 3S+B Capacitive touch control
Portata intensiva Booster airflow	691 m³/h
Livello sonoro min-max Noise level min-max	49 - 65 db(A)
Assorbimento totale Total absorption	255 W

Filtro grassi alluminio incluso Grease aluminium filter included
Camino incluso Chimney included

ACCESSORI ACCESSORIES

Filtro carbone Charcoal filter	CFC0140343
Filtro carbone rigenerabile Regenerable charcoal filter	CFC0162221

MODELLI MODELS

MAJESTIC BL/A/60	PRF0117381A
MAJESTIC BL/A/90	PRF0116967A
MAJESTIC WH/A/60	PRF0124235A
MAJESTIC WH/A/90	PRF0124236A

OM AIR

ELICA DESIGN CENTER



75 cm

Filtrante Filtering

Vetro bianco, vetro nero

White glass, black glass

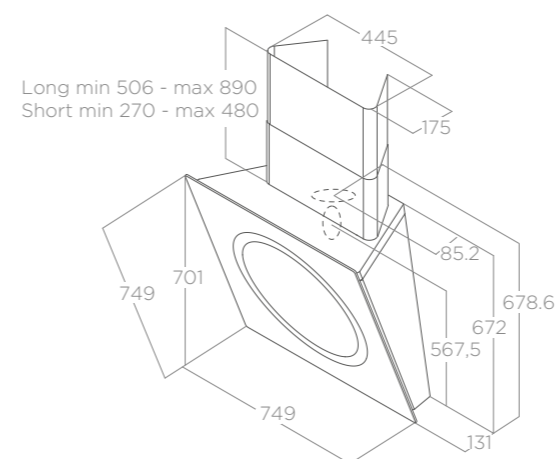

Long min 506 - max 890
Short min 270 - max 480



Al momento dell'attivazione, l'anello centrale si muove elettronicamente verso l'interno consentendo alla cappa di attivare l'aspirazione perimetrale.
When activated, the central ring electronically shifts inward, thus allowing the hood to activate perimeter extraction.

ILLUMINAZIONE LIGHTING

Tipo Type	Strip Led 1x7 W
Intensità Intensity	421 LUX
Temperatura Temperature	3500 K

PERFORMANCE PERFORMANCE

Comandi Controls	Touch control capacitivo 3V+I 3S+B Capacitive touch control
Portata intensiva Booster airflow	700 m³/h
Livello sonoro min-max Noise level min-max	52 - 62 db(A)
Assorbimento totale Total absorption	257 W

Filtro grassi alluminio incluso Grease aluminium filter included
Filtro carbone incluso Charcoal filter included

ACCESSORI ACCESSORIES

Filtro carbone Charcoal filter	CFC0140343
Filtro carbone rigenerabile Regenerable charcoal filter	CFC0162221
Kit camino lungo Long chimney kit	KIT0010439
Kit camino corto Short chimney kit	KIT0010700

MODELLI MODELS

OM AIR BL/F/75	PRF0094744
OM AIR WH/F/75	PRF0094734



VERTIGO

ELICA DESIGN CENTER

90 - 120 cm

Filtrante Filtering

Vetro bianco, vetro nero

White glass, black glass



ENERGY CLASS (A++/D)

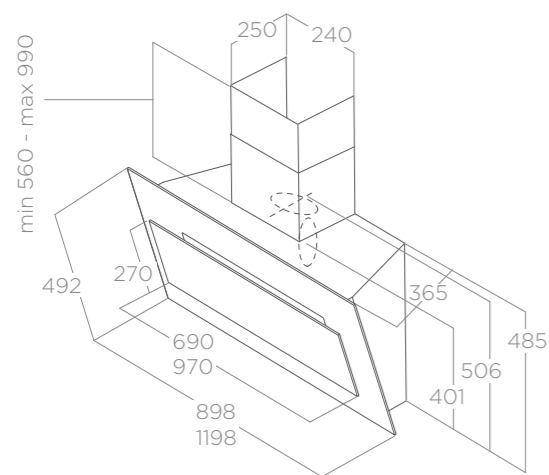

ILLUMINAZIONE LIGHTING	
Tipo Type	STRIP LED 1x7W
Intensità Intensity	301 LUX
Temperatura Temperature	3000 K

PERFORMANCE PERFORMANCE	
Comandi Controls	Touch control infrarossi 3V+I 3S+B Infrared touch control
Portata intensiva Booster airflow	740 m ³ /h
Livello sonoro min-max Noise level min-max	50 - 66 db(A)
Assorbimento totale Total absorption	267 W

Filtro grassi alluminio incluso Grease aluminium filter included
Filtro carbone incluso Charcoal filter included

ACCESSORI ACCESSORIES	
Filtro carbone Charcoal filter	CFC0140343
Filtro carbone rigenerabile Regenerable charcoal filter	CFC0162221
Kit camino acciaio inox Stainless steel chimney kit	KIT0177845

MODELLI MODELS	
VERTIGO BL/F/90	PRF0079553C
VERTIGO BL/F/120	PRF0079555C
VERTIGO WH/F/90	PRF0079554C
VERTIGO WH/F/120	PRF0079556C



ELLE

DESIGN FABRIZIO CRISÀ

80 cm

Filtrante Filtering

Vetro nero, vetro bianco

Black glass, white glass



ENERGY CLASS (A++/D)

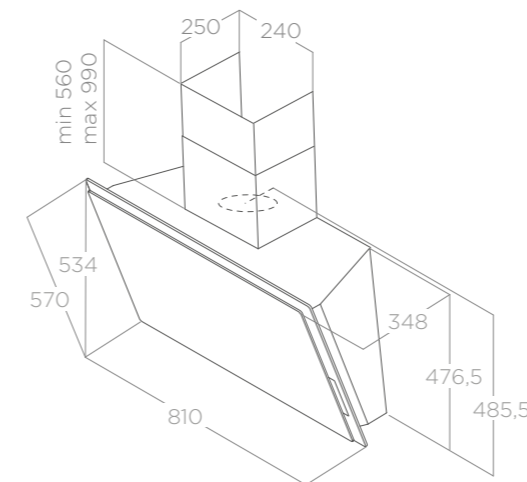

ILLUMINAZIONE LIGHTING	
Tipo Type	Strip Led 1x7 W
Intensità Intensity	365 LUX
Temperatura Temperature	3000 K

PERFORMANCE PERFORMANCE	
Comandi Controls	Touch Control Capacitivo 3V+I 3S+B Capacitive touch control
Portata intensiva Booster airflow	750 m ³ /h
Livello sonoro min-max Noise level min-max	52 - 65 db(A)
Assorbimento totale Total absorption	257 W

Filtro grassi alluminio incluso Grease aluminium filter included
Filtro carbone incluso Charcoal filter included

ACCESSORI ACCESSORIES	
Filtro carbone Charcoal filter	CFC0140343
Filtro carbone rigenerabile Regenerable charcoal filter	CFC0162221
Kit camino acciaio inox Stainless steel chimney kit	KIT0177845

MODELLI MODELS	
ELLE BL/F/80	PRF0094251B
ELLE WH/F/80	PRF0097706B



STRIPE URBAN ZINC



STRIPE URBAN CAST IRON

BELT

DESIGN FABRIZIO CRISÀ

80 cm

Filtrante Filtering

Vetro nero, vetro bianco, acciaio inox

Black glass, white glass, stainless steel

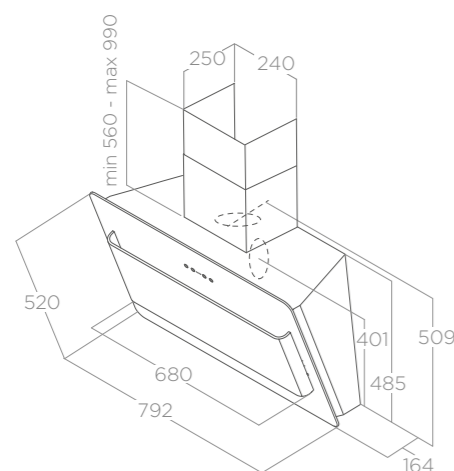

ILLUMINAZIONE LIGHTING

Tipo Type	Led 2x2,5 W
Intensità Intensity	381 LUX
Temperatura Temperature	3500 K

PERFORMANCE PERFORMANCE

	BL/WH	IX
Comandi Controls	Touch control capacitivo 3V+I 3S+B Capacitive touch control	Touch control infrarossi 3V+I 3S+B Infrared touch control
Portata intensiva Booster airflow	590 m³/h	
Livello sonoro min-max Noise level min-max	46 - 61 db(A)	
Assorbimento totale Total absorption	225 W	

Filtro grassi alluminio incluso Grease aluminium filter included
Filtro carbone incluso Charcoal filter included

ACCESSORI ACCESSORIES

Filtro carbone Charcoal filter	CFC0140343
Filtro carbone rigenerabile Regenerable charcoal filter	CFC0162221
Kit camino acciaio inox Stainless steel chimney kit	KIT0177845

MODELLI MODELS

BELT IX/F/80	PRF0033852C
BELT BL/F/80	PRF0032793C
BELT WH/F/80	PRF0038443C

STRIPE URBAN

ELICA DESIGN CENTER

90 cm

Aspirante Duct-out

Metallo effetto ghisa, metallo effetto zincato

Cast iron effect metal, zinc coating effect metal

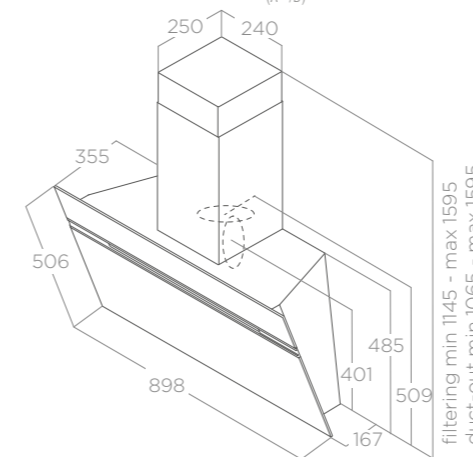
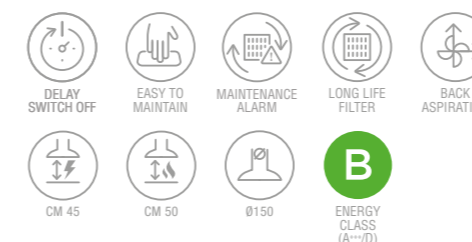

ILLUMINAZIONE LIGHTING

Tipo Type	Led 2x2,5 W
Intensità Intensity	381 LUX
Temperatura Temperature	3500 K

PERFORMANCE PERFORMANCE

	Pulsantiera elettronica 3V+I 3S+B Electronic push button
Comandi Controls	
Portata intensiva Booster airflow	757 m³/h
Livello sonoro min-max Noise level min-max	50 - 65 db(A)
Assorbimento totale Total absorption	265 W

Filtro grassi alluminio incluso Grease aluminium filter included
Camino incluso Chimney included

ACCESSORI ACCESSORIES

Filtro carbone Charcoal filter	CFC0140343
Filtro carbone rigenerabile Regenerable charcoal filter	CFC0162221

MODELLI MODELS

STRIPE URBAN ZINC/A/90	PRF0147739
STRIPE URBAN CAST IRON/A/90	PRF0147738



In linea con i nuovi trend delle cucine, che vede sempre più presente un design industrial e Urban, Elica ha ideato nuove combinazioni di finiture che permettono alla cappa di integrarsi perfettamente con questo stile.

In line with latest kitchen trends, where industrial and urban design is continuously gaining ground, Elica has developed new combinations of finishes allowing the hood to be perfectly integrated with this style.

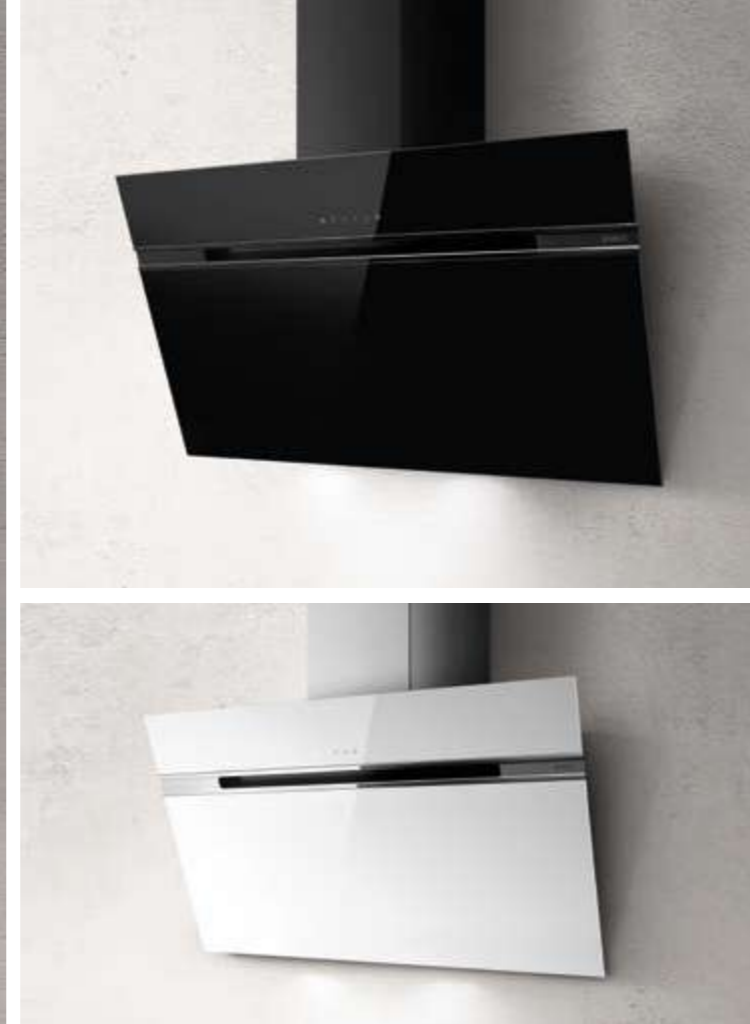

STRIPE

ELICA DESIGN CENTER

60 - 80 - 90 cm
Aspirante Duct-out
Vetro nero, vetro bianco, acciaio inox
Black glass, white glass, stainless steel

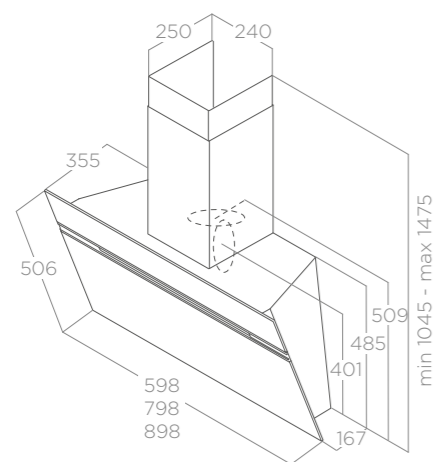
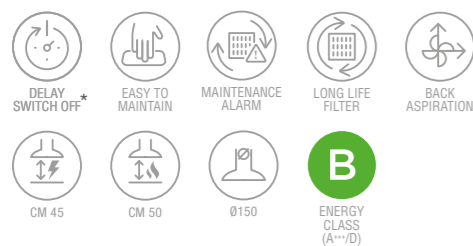

ILLUMINAZIONE LIGHTING	
Tipo Type	Led 2x2,5 W
Intensità Intensity	203 LUX
Temperatura Temperature	3000 K

PERFORMANCE PERFORMANCE	
Comandi Controls	BL/WH Touch control capacitivo 3V+I 3S+B Capacitive touch control IX Pulsantiera elettronica 3V+I 3S+B Electronic push button
Portata intensiva Booster airflow	757 m ³ /h
Livello sonoro min-max Noise level min-max	50 - 65 db(A)
Assorbimento totale Total absorption	265 W

Filtro grassi alluminio incluso Grease aluminium filter included
Camino incluso Chimney included

ACCESSORI ACCESSORIES	
Filtro carbone Charcoal filter	CFC0140343
Filtro carbone rigenerabile Regenerable charcoal filter	CFC0162221

MODELLI MODELS	
STRIPE IX/A/60 (*)	PRF0110514B
STRIPE IX/A/90 (*)	PRF0110515B
STRIPE BL/A/60	PRF0101142B
STRIPE BL/A/80	PRF0164806
STRIPE BL/A/90	PRF0101143B
STRIPE WH/A/60	PRF0101144B
STRIPE WH/A/80	PRF0164805
STRIPE WH/A/90	PRF0101145B



SHEEN-S

DESIGN FABRIZIO CRISÀ

60 - 90 cm
Aspirante Duct-out
Vetro nero, vetro bianco
Black glass, white glass

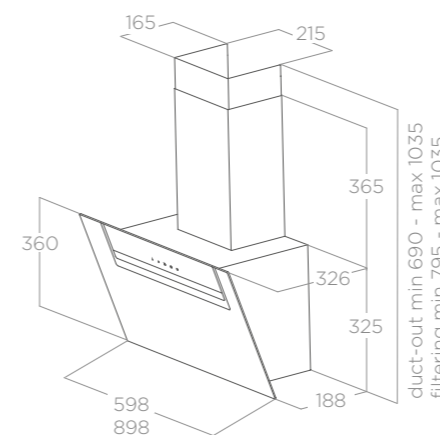

ILLUMINAZIONE LIGHTING	
Tipo Type	Led 2x1,5 W
Intensità Intensity	180 LUX
Temperatura Temperature	3500 K

PERFORMANCE PERFORMANCE	
Comandi Controls	Touch control capacitivo 3V+I 3S+B Capacitive touch control
Portata intensiva Booster airflow	650 m ³ /h
Livello sonoro min-max Noise level min-max	52 - 65 db(A)
Assorbimento totale Total absorption	233 W

Filtro grassi alluminio incluso Grease aluminium filter included
Camino incluso Chimney included

ACCESSORI ACCESSORIES	
Filtro carbone Charcoal filter	CFC0140343
Filtro carbone rigenerabile Regenerable charcoal filter	CFC0162221

MODELLI MODELS	
SHEEN-S BL/A/60	PRF0166928
SHEEN-S BL/A/90	PRF0166929
SHEEN-S WH/A/60	PRF0166930
SHEEN-S WH/A/90	PRF0166931



SHY-S WH/60



SHY-S BL/90



SHY-S

DESIGN FABRIZIO CRISÀ

60 - 90 cm

Aspirante Duct-out

Vetro nero, vetro bianco

Black glass, white glass



DELAY SWITCH OFF



EASY TO MAINTAIN



MAINTENANCE ALARM



LONG LIFE FILTER



CM 45



CM 65



Ø150



ENERGY CLASS (A++/D)

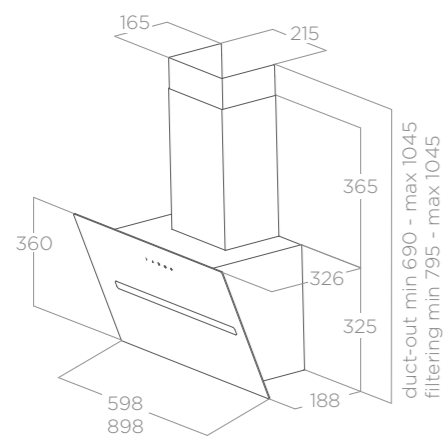

ILLUMINAZIONE LIGHTING

Tipo Type	Led 2x1,5 W
Intensità Intensity	180 LUX
Temperatura Temperature	3500 K

PERFORMANCE PERFORMANCE

Comandi Controls	Touch control capacitivo 3V+I 3S+B Capacitive touch control
Portata intensiva Booster airflow	650 m ³ /h
Livello sonoro min-max Noise level min-max	52 - 65 db(A)
Assorbimento totale Total absorption	233 W

Filtro grassi alluminio incluso Grease aluminium filter included
Camino incluso Chimney included

ACCESSORI ACCESSORIES

Filtro carbone Charcoal filter	CFC0140343
Filtro carbone rigenerabile Regenerable charcoal filter	CFC0162221

MODELLI MODELS

SHY-S BL/A/60	PRF0166932
SHY-S BL/A/90	PRF0166933
SHY-S WH/A/60	PRF0166934
SHY-S WH/A/90	PRF0166935

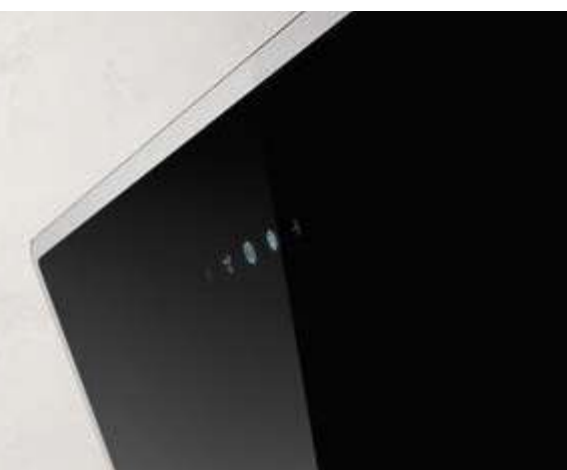

SHIRE

DESIGN FABRIZIO CRISÀ

60 - 90 cm

Aspirante Duct-out

Vetro nero, vetro bianco

Black glass, white glass



DELAY SWITCH OFF



EASY TO MAINTAIN



MAINTENANCE ALARM



LONG LIFE FILTER



CM 45



CM 65



Ø150



ENERGY CLASS (A++/D)

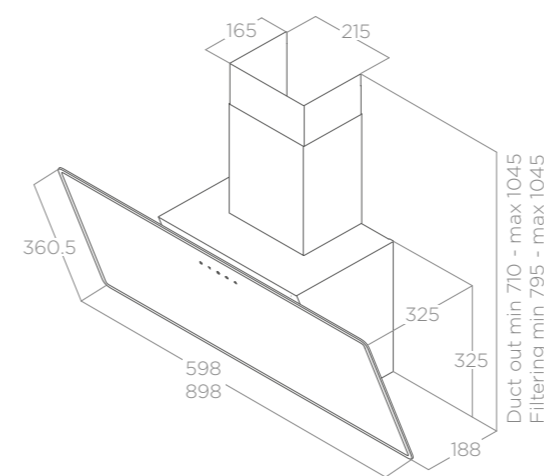

ILLUMINAZIONE LIGHTING

Tipo Type	Led 2x1 W
Intensità Intensity	120 LUX
Temperatura Temperature	3500 K

PERFORMANCE PERFORMANCE

Comandi Controls	Touch control capacitivo 2V+I 2S+B Capacitive touch control
Portata intensiva Booster airflow	650 m ³ /h
Livello sonoro min-max Noise level min-max	52 - 64 db(A)
Assorbimento totale Total absorption	232 W

Filtro grassi alluminio incluso Grease aluminium filter included
Camino incluso Chimney included

ACCESSORI ACCESSORIES

Filtro carbone Charcoal filter	CFC0140343
Filtro carbone rigenerabile Regenerable charcoal filter	CFC0162221

MODELLI MODELS

SHIRE BL/A/60	PRF0119819A
SHIRE BL/A/90	PRF0119829A
SHIRE WH/A/60	PRF0119823A
SHIRE WH/A/90	PRF0119828A

HAIKU

DESIGN FABRIZIO CRISÀ





HAIKU

DESIGN FABRIZIO CRISÀ



60 - 90 - 120 cm
 Aspirante Duct-out
 Vetro nero, Krion bianco, acciaio inox
 Black glass, white Krion, stainless steel

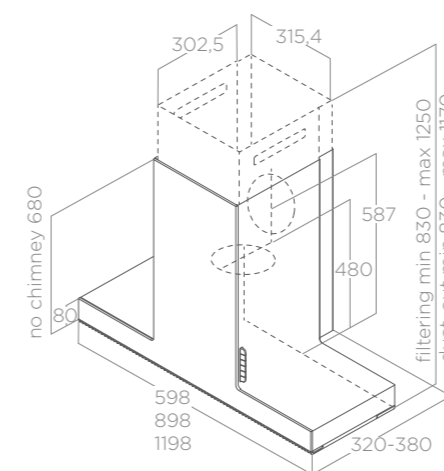

➤ Possibilità di installazione, in modalità aspirante o filtrante, senza ausilio del camino superiore, restando in un'altezza di 680 mm
 Possibility for installation in extraction or filtration mode, without the aid of the upper chimney, remaining within a height of 680 mm

ILLUMINAZIONE LIGHTING

Tipo Type	Strip Led 1x7 W
Intensità Intensity	253 LUX
Temperatura Temperature	3500 K

PERFORMANCE PERFORMANCE

Comandi Controls	Pulsantiera elettronica 3V+2I 3S+2B Electronic push button
Portata intensiva Booster airflow	690 m ³ /h
Livello sonoro min-max Noise level min-max	34 - 51 db(A)
Assorbimento totale Total absorption	277 W

Filtro grassi alluminio incluso Grease aluminium filter included
 Camino incluso Chimney included

ACCESSORI ACCESSORIES

Filtro carbone Charcoal filter	CFC0141529A
Filtro carbone rigenerabile Regenerable charcoal filter	CFC0141725A

MODELLI MODELS

HAIKU IX/A/60	PRF0146255
HAIKU IX/A/90	PRF0146256
HAIKU IX/A/120	PRF0146257
HAIKU BL/A/60	PRF0146264
HAIKU BL/A/90	PRF0146265
HAIKU BL/A/120	PRF0146266
HAIKU WH/A/60	PRF0146268
HAIKU WH/A/90	PRF0146269
HAIKU WH/A/120	PRF0146270



Shift 3238 system - l'unico sistema a profondità regolabile
Shift 3238 system - the only system with adjustable depth

Elica, per prima sul mercato, propone per Haiku SHIFT 3238 un sistema innovativo di staffe a muro, grazie al quale le operazioni di installazione si semplificano. Sarà possibile scegliere la posizione di Haiku per averla in linea con i pensili o per aumentare lo spazio di azione sul piano cottura. SHIFT 3238 permette al corpo cappa di regolare millimetricamente la sua profondità. I vincoli semplicemente spariscono e si moltiplicano le soluzioni estetiche e i vantaggi nelle operazioni di pulizia.

Elica was the first in the market to propose an innovative wall-mounted bracket system in Haiku SHIFT 3238, thanks to which installation operations have been largely simplified. Haiku can be positioned either in line with the shelves or in such a way as to increase the work space on the hob. SHIFT 3238 allows the millimetric adjustment of the hood body depth. Limitations simply disappear and aesthetic solutions multiply, as do the advantages of cleaning operations.

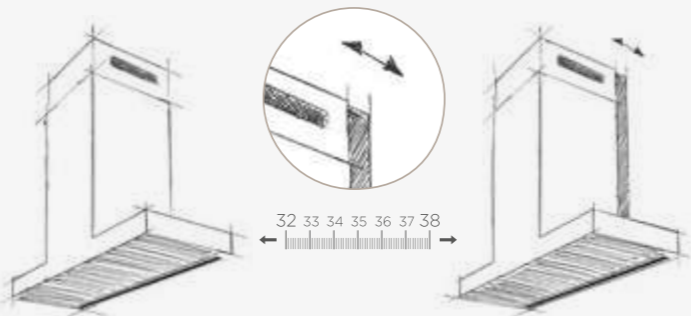

HAIKU 32
 DESIGN FABRIZIO CRISÀ



32 cm
 Aspirante Duct-out
 Vetro nero, Krion bianco, acciaio inox
 Black glass, white Krion, stainless steel

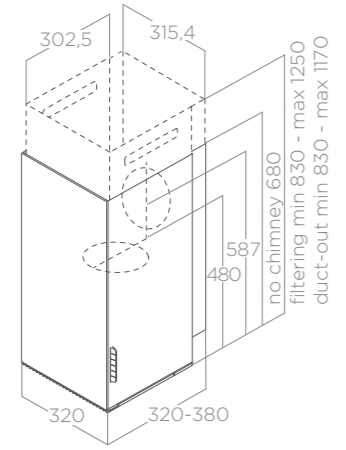
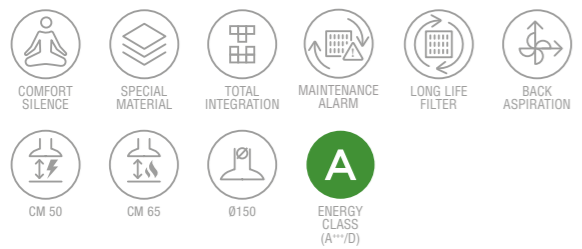

ILLUMINAZIONE LIGHTING	
Tipo Type	Strip Led 1x7 W
Intensità Intensity	253 LUX
Temperatura Temperature	3500 K

PERFORMANCE PERFORMANCE	
Comandi Controls	Pulsantiera elettronica 3V+2I 3S+2B Electronic push button
Portata intensiva Booster airflow	690 m³/h
Livello sonoro min-max Noise level min-max	34 - 51 db(A)
Assorbimento totale Total absorption	277 W

Filtro grassi alluminio incluso Grease aluminium filter included
 Camino incluso Chimney included

ACCESSORI ACCESSORIES	
Filtro carbone Charcoal filter	CFC0141529A
Filtro carbone rigenerabile Regenerable charcoal filter	CFC0141725A

MODELLI MODELS	
HAIKU IX/A/32	PRF0146254
HAIKU BL/A/32	PRF0146263
HAIKU WH/A/32	PRF0146267

Possibilità di installazione, in modalità aspirante o filtrante, senza ausilio del camino superiore, restando in un'altezza di 680 mm
 Possibility for installation in extraction or filtration mode, without the aid of the upper chimney, remaining within a height of 680 mm

Visioni metriche
Metric visions



Haiku, grazie alla varietà di dimensioni proposte, è perfetta per diverse soluzioni progettuali. È disponibile sia nella versione a parete (32, 60, 90 e 120cm) che a isola (32, 120, 180cm), nelle modalità aspirante e filtrante.

Thanks to the sizes in which it is proposed, Haiku is perfect for a range of design solutions. It is available in both a wall-mounted version (32, 60, 90 and 120 cm) and island version (32, 120, 180 cm), in both an extractor and filtration version.

BIO

DESIGN FABRIZIO CRISÀ





BIO

DESIGN FABRIZIO CRISÀ





90 cm

Aspirante Duct-out

Rovere naturale + bianco effetto soft touch

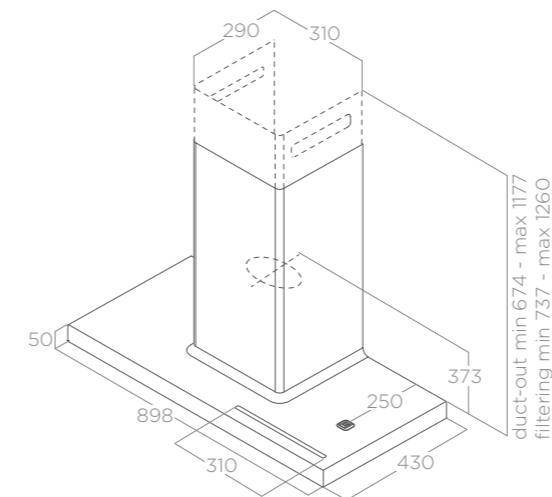
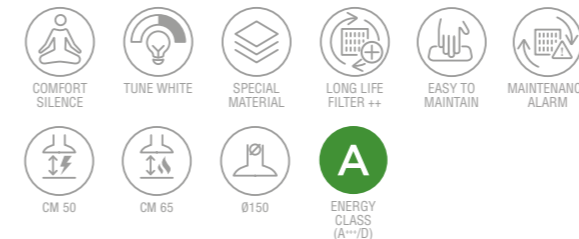
Natural oak + white soft touch effect



 Possibilità di installazione, in modalità aspirante o filtrante, senza ausilio del camino superiore, restando in un'altezza di 678 mm
 Possibility for installation in extraction or filtration mode, without the aid of the upper chimney, remaining within a height of 678 mm

ILLUMINAZIONE LIGHTING

Tipo Type	Strip Led 1x7 W
Intensità Intensity	113 LUX
Temperatura Temperature	2700 - 6500 K

PERFORMANCE PERFORMANCE

Comandi Controls	Pulsantiera elettronica 3V+2I 3S+2B Electronic push button
Portata intensiva Booster airflow	720 m ³ /h
Livello sonoro min-max Noise level min-max	35 - 58 db(A)
Assorbimento totale Total absorption	257 W

Filtro grassi alluminio incluso Grease aluminium filter included
Camino incluso Chimney included

ACCESSORI ACCESSORIES

Filtro carbone rigenerabile Regenerable charcoal filter	CFC0141725A
Kit prima installazione filtrante HP First installation HP filtering kit	KIT0160440
Filtro carbone rigenerabile HP Regenerable charcoal HP filter	CFC0140091
Kit mensola muro rovere 60cm Oak wall shelf kit 60cm	KIT0120946
Radiocomando Design bianco White Design remote control	KIT0121468
Radiocomando Design nero Black Design remote control	KIT0121469

MODELLI MODELS

BIO WH/A 90 ROVERE	PRF0147266
--------------------	------------

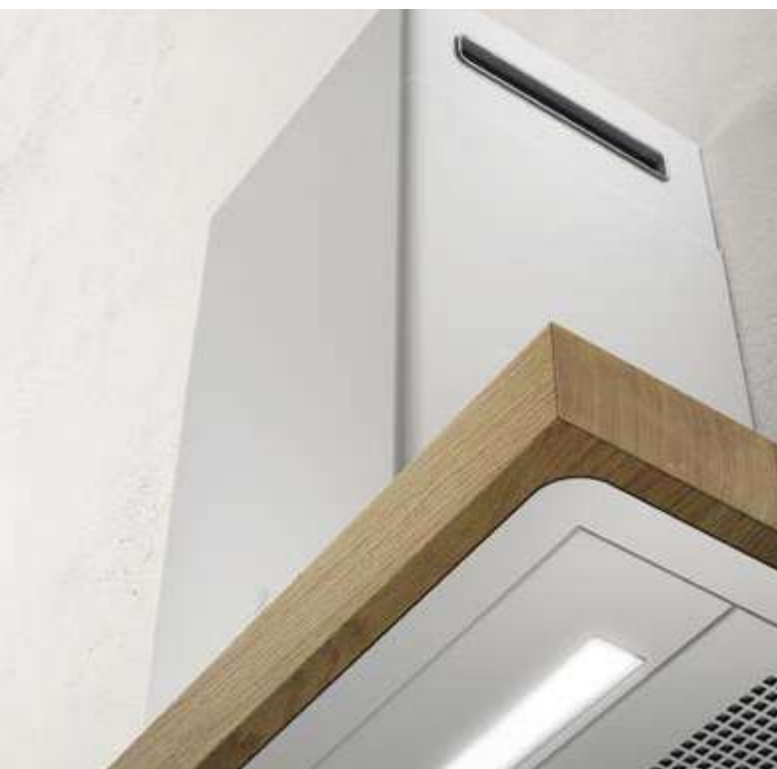



METEORITE

DESIGN FABRIZIO CRISÀ

90 - 120 cm

Aspirante Duct-out

Acciaio inox + vetro nero

Stainless steel + black glass

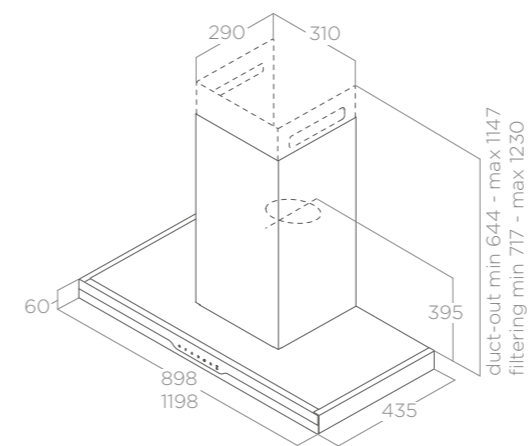
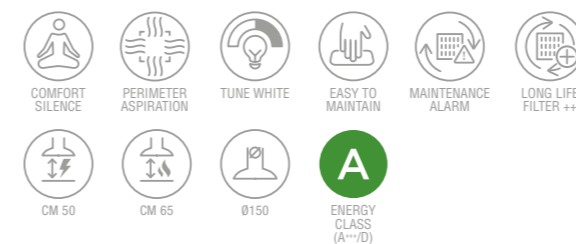

ILLUMINAZIONE LIGHTING

Tipo Type	Strip Led 1x7 W
Intensità Intensity	113 LUX
Temperatura Temperature	2700 - 6500 K

PERFORMANCE PERFORMANCE

Comandi Controls	Touch control capacitivo 3V+2I 3S+2B Capacitive touch control
Portata intensiva Booster airflow	700 m ³ /h
Livello sonoro min-max Noise level min-max	32 - 56 db(A)
Assorbimento totale Total absorption	257 W

Filtro grassi alluminio incluso Grease aluminium filter included
Camino incluso Chimney included

ACCESSORI ACCESSORIES

Filtro carbone rigenerabile Regenerable charcoal filter	CFC0141725A
Filtro carbone rigenerabile HP Regenerable charcoal filter HP	CFC0140091
Kit prima installazione filtrante HP First installation HP filtering kit	KIT0160440

MODELLI MODELS

METEORITE IX/A/90	PRF0147272
METEORITE IX/A/120	PRF0147273



SWEET
DESIGN FABRIZIO CRISÀ



SWEET PELTROX



SWEET

DESIGN FABRIZIO CRISÀ



SWEET WHITE



SWEET IVORY



SWEET UMBER



SWEET COPPER



SWEET CAST IRON

85 cm

Aspirante, Filtrante Duct-out, Filtering

Verniciature: bianco opaco, tortora opaco, avorio, rame opaco, peltrox, ghisa
Painted: matt white, matt umber, ivory, matt copper, peltrox, cast iron

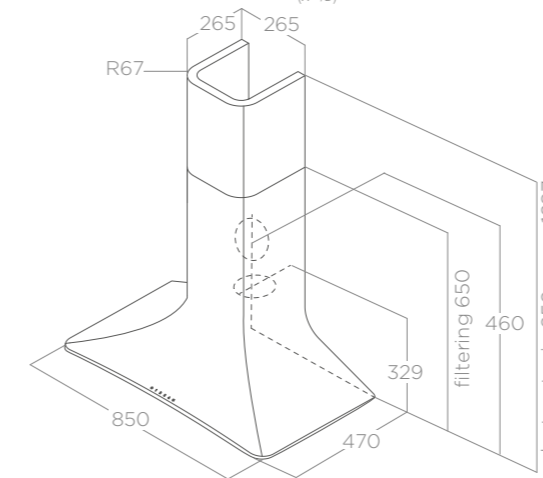

L'utilizzo del tecnopolimero permette di ottenere le linee morbide e caratterizzanti del design di Sweet. Disponibile sia in versione filtrante senza estensione camino che in versione aspirante con kit camino prolunga compreso nell'imballo.

The use of engineering plastics makes it possible to create the soft contours typical of the Sweet design. Available in both a filtration version without flue extension and extraction version with flue extension kit included in the packaging.

ILLUMINAZIONE LIGHTING

Tipo Type	Strip Led 1x7 W
Intensità Intensity	197 LUX
Temperatura Temperature	4000 K

PERFORMANCE PERFORMANCE

Comandi Controls	Touch control capacitivo 3V+I 3S+B Capacitive touch control
Portata intensiva Booster airflow	580 m ³ /h
Livello sonoro min-max Noise level min-max	46 - 61 db(A)
Assorbimento totale Total absorption	207 W

Filtro grassi alluminio incluso Grease aluminium filter included
Filtro carbone rigenerabile incluso (*) Regenerable charcoal filter included (*)
Estensione camino incluso (Aspirante) Extension chimney included (Duct-out)

ACCESSORI ACCESSORIES

Filtro carbone rigenerabile Regenerable charcoal filter	CFC0140426
---	------------

MODELLI MODELS

SWEET WHITE/A/85+CAM	PRF0167320
SWEET WHITE F/85 (*)	PRF0043030A
SWEET UMBER/A/85+CAM	PRF0167321
SWEET UMBER F/85 (*)	PRF0043031A
SWEET IVORY/A/85+CAM	PRF0167322
SWEET IVORY F/85 (*)	PRF0043033A
SWEET COPPER/A/85+CAM	PRF0167324
SWEET COPPER/F/85 (*)	PRF0120672A
SWEET PELTROX/A/85+CAM	PRF0167323
SWEET PELTROX/F/85 (*)	PRF0120689A
SWEET CAST IRON/A/85+CAM	PRF0167319
SWEET CAST IRON/F/85 (*)	PRF0120702A



ADÉLE
DESIGN FABRIZIO CRISÀ



ADÉLE BLIX



ADÉLE

DESIGN FABRIZIO CRISÀ

60 - 90 cm

Aspirante Duct-out

Acciaio inox + vetro nero, nero effetto soft touch + vetro nero

Stainless steel + black glass, black soft touch effect + black glass



EASY TO MAINTAIN

MAINTENANCE ALARM

LONG LIFE FILTER

CM 50

CM 65

Ø150

ENERGY CLASS (A++/D)

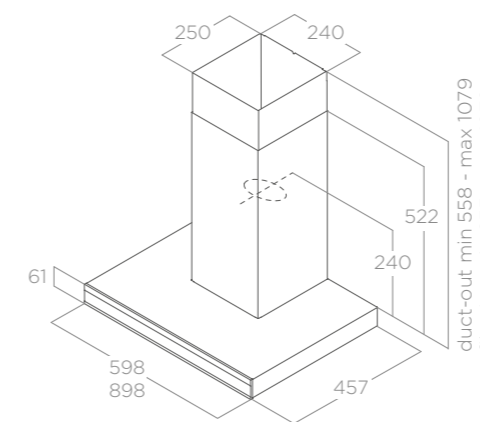

ADÉLE BL MAT

ILLUMINAZIONE LIGHTING

Tipo Type	STRIP LED 1x7 W
Intensità Intensity	421 LUX
Temperatura Temperature	3000 K

PERFORMANCE PERFORMANCE

Comandi Controls	Touch control capacitivo 3V+I 3S+B Capacitive touch control
Portata intensiva Booster airflow	770 m ³ /h
Livello sonoro min-max Noise level min-max	55 - 69 db(A)
Assorbimento totale Total absorption	277 W

Filtro grassi alluminio incluso Grease aluminium filter included
Camino incluso Chimney included

ACCESSORI ACCESSORIES

Filtro carbone Charcoal filter	CFC0141529A
Filtro carbone rigenerabile Regenerable charcoal filter	CFC0141725A
Kit prolunga camino acciaio inox H81 Stainless steel chimney extension kit H81	KIT00780
Kit prolunga camino nero H81 Black chimney extension kit H81	KIT0181149

MODELLI MODELS

ADÉLE BLIX/A/60	PRF0167314
ADÉLE BLIX/A/90	PRF0167315
ADÉLE BL MAT/A/60	PRF0182412
ADÉLE BL MAT/A/90	PRF0182410



JOY

ELICA DESIGN CENTER

60 - 90 cm

Aspirante Duct-out

Acciaio inox + vetro bianco, acciaio inox + vetro nero

Stainless steel + white glass, stainless steel + black glass



EASY TO MAINTAIN



MAINTENANCE ALARM



LONG LIFE FILTER



CM 50



CM 65



Ø150



ENERGY CLASS (A++-D)

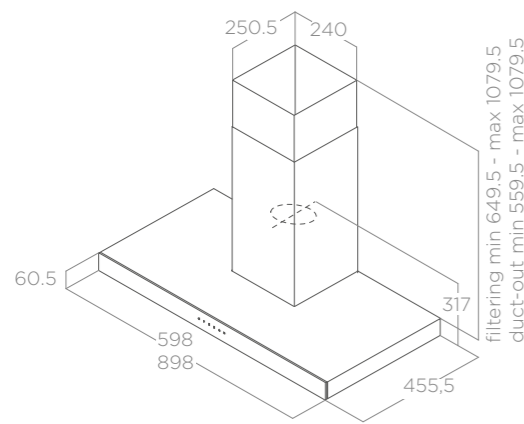

ILLUMINAZIONE LIGHTING	
Tipo Type	Led 2x2,5 W
Intensità Intensity	381 LUX
Temperatura Temperature	3500 K
PERFORMANCE PERFORMANCE	
Comandi Controls	Touch control capacitivo 3V+I 3S+B Capacitive touch control
Portata intensiva Booster airflow	713 m ³ /h
Livello sonoro min-max Noise level min-max	51 - 69 db(A)
Assorbimento totale Total absorption	265 W

Filtro grassi alluminio incluso Grease aluminium filter included
Camino incluso Chimney included

ACCESSORI ACCESSORIES	
Filtro carbone Charcoal filter	CFC0141529A
Filtro carbone rigenerabile Regenerable charcoal filter	CFC0141725A
Kit prolunga camino acciaio inox H81 Stainless steel chimney extension Kit H81	KIT00780

MODELLI MODELS	
JOY BLIX/A/60	PRF0104625A
JOY BLIX/A/90	PRF0104626A
JOY WHIX/A/60	PRF0104630A
JOY WHIX/A/90	PRF0104631A

GALAXY

ELICA DESIGN CENTER

80 cm

Aspirante Duct-out

Acciaio inox + vetro nero, acciaio inox + vetro bianco

Stainless steel + black glass, stainless steel + white glass



EASY TO MAINTAIN



DELAY SWITCH OFF



MAINTENANCE ALARM



LONG LIFE FILTER



CM 50



CM 65



Ø150



ENERGY CLASS (A++-D)

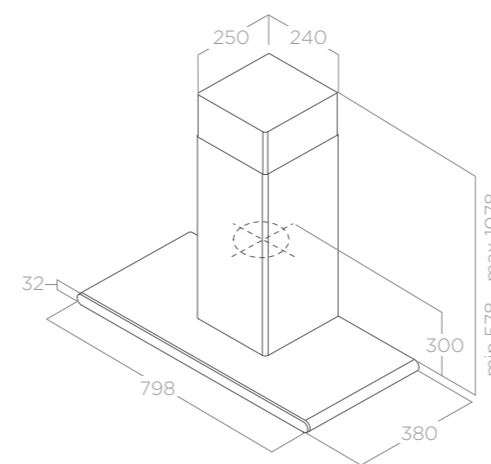

ILLUMINAZIONE LIGHTING	
Tipo Type	Led 2x2,5 W
Intensità Intensity	145 LUX
Temperatura Temperature	3500 K
PERFORMANCE PERFORMANCE	
Comandi Controls	Touch control capacitivo 3V+I 3S+B Capacitive touch control
Portata intensiva Booster airflow	647 m ³ /h
Livello sonoro min-max Noise level min-max	52 - 71 db(A)
Assorbimento totale Total absorption	265 W

Filtro grassi alluminio incluso Grease aluminium filter included
Camino incluso Chimney included

ACCESSORI ACCESSORIES	
Filtro carbone Charcoal filter	CFC0141529A
Filtro carbone rigenerabile Regenerable charcoal filter	CFC0141725A

MODELLI MODELS	
GALAXY BLIX/A/80	PRF0008948B
GALAXY WHIX/A/80	PRF0009822B



THIN

DESIGN FABRIZIO CRISÀ

60 - 90 - 120 cm
Aspirante Duct-out
Acciaio inox Stainless steel

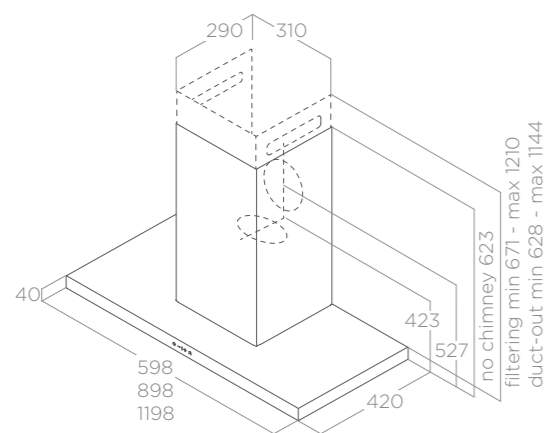

ILLUMINAZIONE LIGHTING	
Tipo Type	Strip Led 1x7 W
Intensità Intensity	477 LUX
Temperatura Temperature	3500 K

PERFORMANCE PERFORMANCE	
Comandi Controls	Touch control infrarossi 3V+2I 3S+2B Infrared touch control
Portata intensiva Booster airflow	680 m ³ /h
Livello sonoro min-max Noise level min-max	34 - 52 db(A)
Assorbimento totale Total absorption	277 W

Filtro grassi alluminio incluso Grease aluminium filter included
Camino incluso Chimney included

ACCESSORI ACCESSORIES	
Filtro carbone Charcoal filter	CFC0141529A
Filtro carbone rigenerabile Regenerable charcoal filter	CFC0141725A

MODELLI MODELS	
THIN IX/A/60	PRF0144970
THIN IX/A/90	PRF0144969
THIN IX/A/120	PRF0144972



LOL

DESIGN FABRIZIO CRISÀ

60 - 90 cm
Aspirante Duct-out
Nero gofrato, acciaio inox
Embossed black, stainless steel

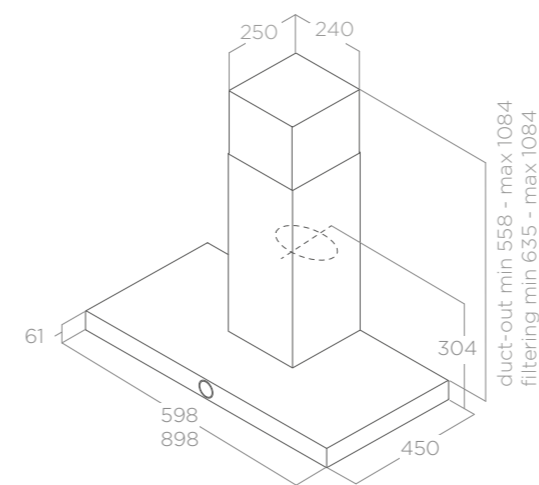

ILLUMINAZIONE LIGHTING	
Tipo Type	Led 2x2,5 W
Intensità Intensity	381 LUX
Temperatura Temperature	3500 K

PERFORMANCE PERFORMANCE	
Comandi Controls	Rotativo elettronico 3V+I 3S+B Electronic rotative
Portata intensiva Booster airflow	680 m ³ /h
Livello sonoro min-max Noise level min-max	52 - 67 db(A)
Assorbimento totale Total absorption	255 W

Filtro grassi alluminio incluso Grease aluminium filter included
Camino incluso Chimney included

ACCESSORI ACCESSORIES	
Filtro carbone Charcoal filter	CFC0141529A
Filtro carbone rigenerabile Regenerable charcoal filter	CFC0141725A
Kit prolunga camino acciaio inox H81 Stainless steel chimney extension Kit H81	KIT00780

MODELLI MODELS	
LOL IX/A/60	PRF0097149A
LOL IX/A/90	PRF0097323A
LOL BL/A/60	PRF0097782A
LOL BL/A/90	PRF0097906A



SPOT PLUS

DESIGN FABRIZIO CRISÀ

60 - 90 - 120 cm
Aspirante Duct-out
Acciaio inox Stainless steel

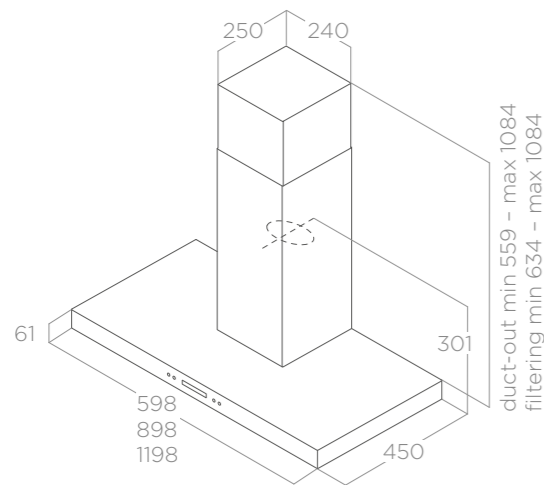
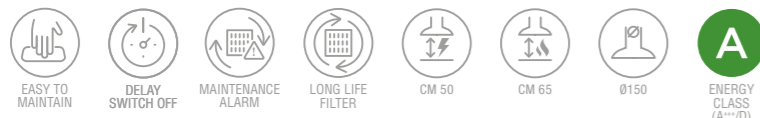

ILLUMINAZIONE LIGHTING	
Tipo Type	Led 2x2,5 W
Intensità Intensity	381 LUX
Temperatura Temperature	3500 K
PERFORMANCE PERFORMANCE	
Comandi Controls	Pulsantiera elettronica con LCD 3V+I 3S+B Electronic push button with LCD
Portata intensiva Booster airflow	620 m ³ /h
Livello sonoro min-max Noise level min-max	52 - 67 db(A)
Assorbimento totale Total absorption	205 W

Filtro grassi alluminio incluso Grease aluminium filter included
Camino incluso Chimney included

ACCESSORI ACCESSORIES	
Filtro carbone Charcoal filter	CFC0141529A
Filtro carbone rigenerabile Regenerable charcoal filter	CFC0141725A
Kit prolunga camino acciaio inox H81 Stainless steel chimney extension kit H81	KIT00780

MODELLI MODELS	
SPOT PLUS IX/A/60	PRF0097374A
SPOT PLUS IX/A/90	PRF0097373A
SPOT PLUS IX/A/120	PRF0100242A



SPOT URBAN ZINC



SPOT URBAN CAST IRON

SPOT URBAN

ELICA DESIGN CENTER

90 cm
Aspirante Duct-out
Metallo effetto ghisa, metallo effetto zincato
Cast iron effect metal, zinc coating effect metal

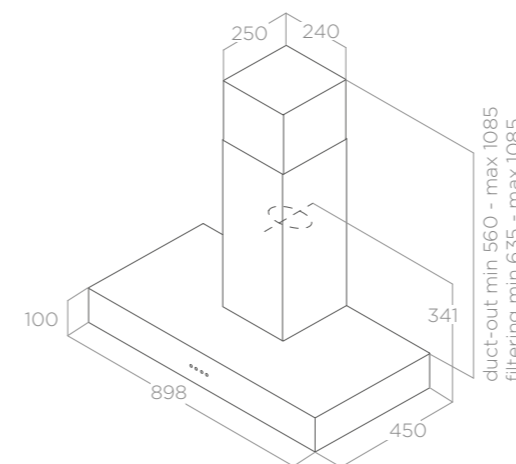

In linea con i nuovi trend delle cucine, che vede sempre più presente un design industrial e Urban, Elica ha ideato nuove combinazioni di finiture che permettono alla cappa di integrarsi perfettamente con questo stile. In line with latest kitchen trends, where industrial and urban design is continuously gaining ground, Elica has developed new combinations of finishes allowing the hood to be perfectly integrated with this style.

ILLUMINAZIONE LIGHTING	
Tipo Type	Led 2x2,5 W
Intensità Intensity	381 LUX
Temperatura Temperature	3500 K
PERFORMANCE PERFORMANCE	
Comandi Controls	Pulsantiera meccanica 3V 3S Mechanical push button
Portata massima Max airflow	630 m ³ /h
Livello sonoro min-max Noise level min-max	52 - 71 db(A)
Assorbimento totale Total absorption	255 W

Filtro grassi alluminio incluso Grease aluminium filter included
Camino incluso Chimney included

ACCESSORI ACCESSORIES	
Filtro carbone Charcoal filter	CFC0141529A
Filtro carbone rigenerabile Regenerable charcoal filter	CFC0141725A

MODELLI MODELS	
SPOT URBAN CAST IRON/A/90	PRF0147736
SPOT URBAN ZINC/A/90	PRF0147737



SPOT NG

ELICA DESIGN CENTER

60 - 90 - 120 cm (H6 - H10)
Aspirante Duct-out
Acciaio inox Stainless steel

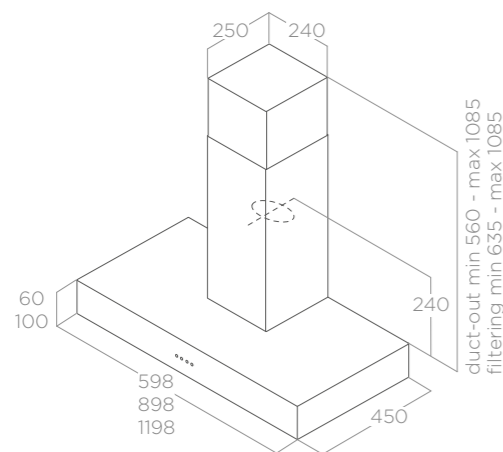

ILLUMINAZIONE LIGHTING	
Tipo Type	Led 2x2,5 W (60cm,90cm) - Led 3x2,5 W (120cm)
Intensità Intensity	381 (60cm,90cm) - 571 LUX (120cm)
Temperatura Temperature	3500 K

PERFORMANCE PERFORMANCE	
Comandi Controls	Pulsantiera meccanica 3V 3S Mechanical push button
Portata massima Max airflow	368 m ³ /h
Livello sonoro min-max Noise level min-max	55 - 62 db(A)
Assorbimento totale Total absorption	140 W (60cm,90cm) - 142.5 W (120cm)

Filtro grassi alluminio incluso Grease aluminium filter included
Camino incluso Chimney included

ACCESSORI ACCESSORIES	
Filtro carbone Charcoal filter	CFC0141529A
Filtro carbone rigenerabile Regenerable charcoal filter	CFC0141725A
Kit prolunga camino acciaio inox H81 Stainless steel chimney extension kit H81	KIT00780

MODELLI MODELS	
SPOT NG H10 IX/A/60	55916386A
SPOT NG H10 IX/A/90	55916387A
SPOT NG H10 IX/A/120	PRF0099408A
SPOT NG H6 IX/A/60	55916388A
SPOT NG H6 IX/A/90	55916389A
SPOT NG H6 IX/A/120	PRF0099407A



CRUISE

ELICA DESIGN CENTER

60 - 90 cm
Aspirante Duct-out
Acciaio inox Stainless steel

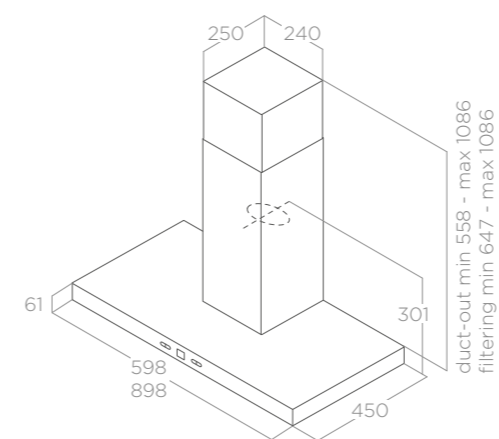
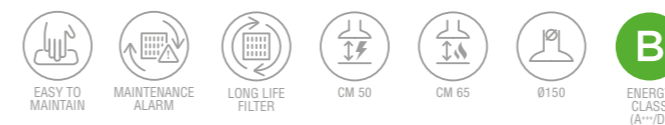

ILLUMINAZIONE LIGHTING	
Tipo Type	Led 2x2,5 W
Intensità Intensity	145 LUX
Temperatura Temperature	3500 K

PERFORMANCE PERFORMANCE	
Comandi Controls	Pulsantiera elettronica con display 3V+I 3S+B Electronic push button with display
Portata intensiva Booster airflow	713 m ³ /h
Livello sonoro min-max Noise level min-max	51 - 69 db(A)
Assorbimento totale Total absorption	265 W

Filtro grassi alluminio incluso Grease aluminium filter included
Camino incluso Chimney included

ACCESSORI ACCESSORIES	
Filtro carbone Charcoal filter	CFC0141529A
Filtro carbone rigenerabile Regenerable charcoal filter	CFC0141725A
Kit prolunga camino acciaio inox H81 Stainless steel chimney extension kit H81	KIT00780

MODELLI MODELS	
CRUISE IX/A/60	PRF0147062
CRUISE IX/A/90	PRF0147074



TRIBE

ELICA DESIGN CENTER

60 - 90 cm

Aspirante Duct-out

Acciaio inox + vetro

Stainless steel + glass



EASY TO MAINTAIN



MAINTENANCE ALARM



LONG LIFE FILTER



CM 50



CM 65



Ø150



ENERGY CLASS (A++/D)

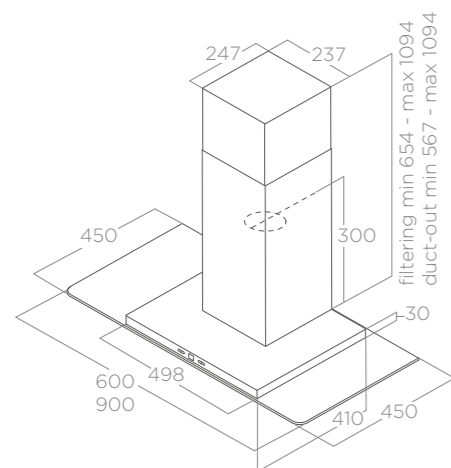

ILLUMINAZIONE LIGHTING	
Tipo Type	Led 2x2,5 W
Intensità Intensity	381 LUX
Temperatura Temperature	3000 K
PERFORMANCE PERFORMANCE	
Comandi Controls	Pulsantiera elettronica con display 3V+I 3S+B Electronic push button with display
Portata intensiva Booster airflow	600 m ³ /h
Livello sonoro min-max Noise level min-max	48 - 64 db(A)
Assorbimento totale Total absorption	205 W

Filtro grassi alluminio incluso Grease aluminium filter included
Camino incluso Chimney included

ACCESSORI ACCESSORIES	
Filtro carbone Charcoal filter	CFC0141529A
Filtro carbone rigenerabile Regenerable charcoal filter	CFC0141725A
Kit prolunga camino acciaio inox H81 Stainless steel chimney extension kit H81	KIT00780

MODELLI MODELS	
TRIBE A IX/A/60	PRF0150292
TRIBE A IX/A/90	PRF0150291



FLAT GLASS

ELICA DESIGN CENTER

60 - 90 cm

Aspirante Duct-out

Acciaio Inox + vetro

Stainless steel + glass



LONG LIFE FILTER



CM 50



CM 65



Ø150



ENERGY CLASS (A++/D)

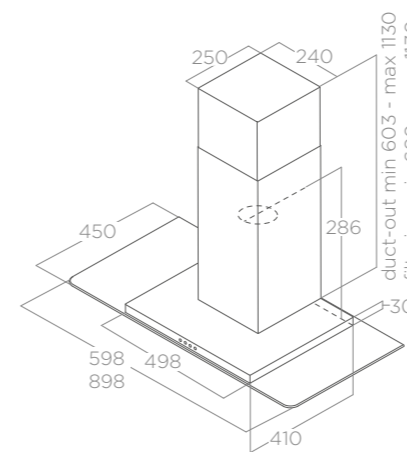

ILLUMINAZIONE LIGHTING	
Tipo Type	Led 2x2,5 W
Intensità Intensity	381 LUX
Temperatura Temperature	3500 K
PERFORMANCE PERFORMANCE	
Comandi Controls	Pulsantiera meccanica 3V 3S Mechanical push button
Portata massima Max airflow	368 m ³ /h
Livello sonoro min-max Noise level min-max	55 - 62 db(A)
Assorbimento totale Total absorption	140 W

Filtro grassi alluminio incluso Grease aluminium filter included
Camino incluso Chimney included

ACCESSORI ACCESSORIES	
Filtro carbone Charcoal filter	CFC0141529A
Filtro carbone rigenerabile Regenerable charcoal filter	CFC0141725A
Kit prolunga camino acciaio inox H81 Stainless steel chimney extension kit H81	KIT00780

MODELLI MODELS	
FLAT GLASS IX/A/60	68516391A
FLAT GLASS IX/A/90	68516390A



REEF

ELICA DESIGN CENTER

60 - 90 cm
Aspirante Duct-out
Acciaio inox + vetro
Stainless steel + glass

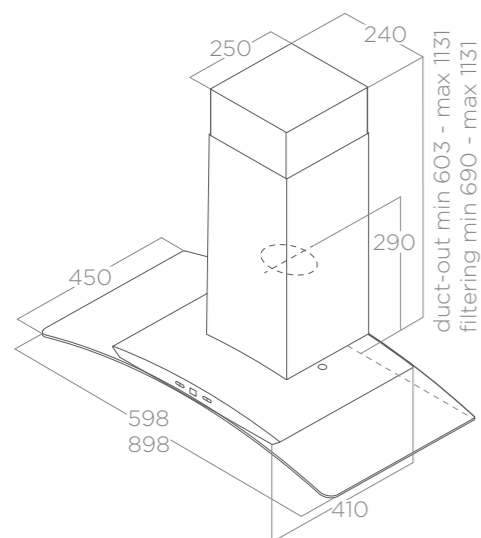
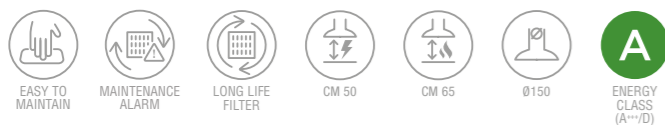

ILLUMINAZIONE LIGHTING	
Tipo Type	Led 2x2,5 W
Intensità Intensity	381 LUX
Temperatura Temperature	3000 K
PERFORMANCE PERFORMANCE	
Comandi Controls	Pulsantiera elettronica con display 3V+I 3S+B Electronic push button with display
Portata intensiva Booster airflow	600 m ³ /h
Livello sonoro min-max Noise level min-max	48 - 64 db(A)
Assorbimento totale Total absorption	205 W

Filtro grassi alluminio incluso Grease aluminium filter included
Camino incluso Chimney included

ACCESSORI ACCESSORIES	
Filtro carbone Charcoal filter	CFC0141529A
Filtro carbone rigenerabile Regenerable charcoal filter	CFC0141725A
Kit prolunga camino acciaio inox H81 Stainless steel chimney extension kit H81	KIT00780

MODELLI MODELS	
REEF A IX/A/60	PRF0150289
REEF A IX/A/90	PRF0150288



CIRCUS

ELICA DESIGN CENTER

60 - 90 cm
Aspirante Duct-out
Acciaio inox + vetro
Stainless steel + glass

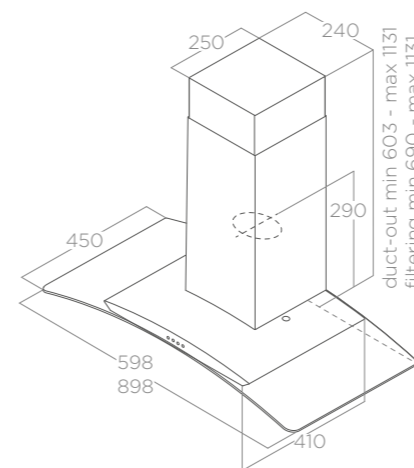

ILLUMINAZIONE LIGHTING	
Tipo Type	Led 2x2,5 W
Intensità Intensity	381 LUX
Temperatura Temperature	3500 K
PERFORMANCE PERFORMANCE	
Comandi Controls	Pulsantiera meccanica 3V 3S Mechanical push button
Portata massima Max airflow	368 m ³ /h
Livello sonoro min-max Noise level min-max	55 - 62 db(A)
Assorbimento totale Total absorption	140 W

Filtro grassi alluminio incluso Grease aluminium filter included
Camino incluso Chimney included

ACCESSORI ACCESSORIES	
Filtro carbone Charcoal filter	CFC0141529A
Filtro carbone rigenerabile Regenerable charcoal filter	CFC0141725A
Kit prolunga camino acciaio inox H81 Stainless steel chimney extension kit H81	KIT00780

MODELLI MODELS	
CIRCUS IX/A/60	68116393A
CIRCUS IX/A/90	68116392A



STONE

ELICA DESIGN CENTER

Ø33 cm
Aspirante Duct-out
Acciaio inox, bianco
Stainless steel, white

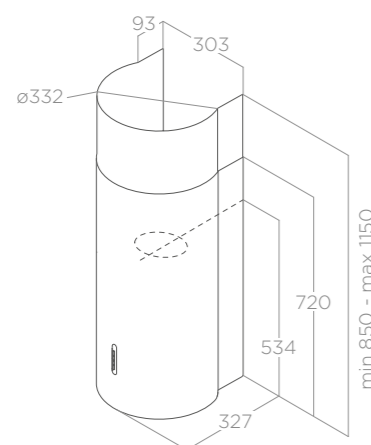

ILLUMINAZIONE LIGHTING	
Tipo Type	Led 2x2,5 W
Intensità Intensity	457 LUX
Temperatura Temperature	2700 K

PERFORMANCE PERFORMANCE	
Comandi Controls	Pulsantiera soft light 3V 3S Soft light push button
Portata massima Max airflow	559 m ³ /h
Livello sonoro min-max Noise level min-max	44 - 67 db(A)
Assorbimento totale Total absorption	180 W

Filtro grassi alluminio incluso Grease aluminium filter included
Camino incluso Chimney included

ACCESSORI ACCESSORIES	
Filtro carbone Charcoal filter	CFC0141529A
Filtro carbone rigenerabile Regenerable charcoal filter	CFC0141725A

MODELLI MODELS	
STONE IX/A/33	61412862B
STONE WH/A/33	PRF0007123A



TUBE PRO

ELICA DESIGN CENTER

Ø 43 cm
Aspirante Duct-out
Acciaio inox, nero effetto soft touch, bianco effetto soft touch
Stainless steel, black soft touch effect, white soft touch effect

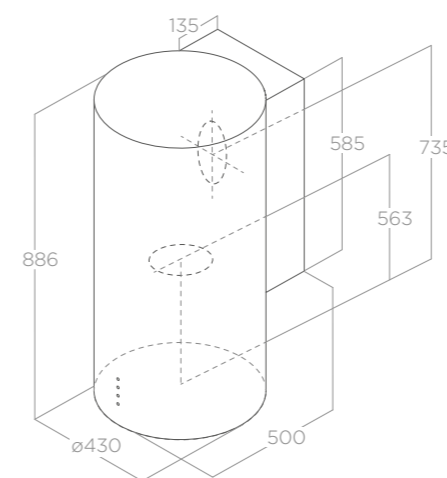
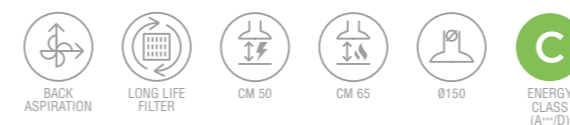

ILLUMINAZIONE LIGHTING	
Tipo Type	Led 2x3 W
Intensità Intensity	457 LUX
Temperatura Temperature	2700 K

PERFORMANCE PERFORMANCE	
Comandi Controls	Pulsantiera meccanica 3V 3S Mechanical push button
Portata massima Max airflow	603 m ³ /h
Livello sonoro min-max Noise level min-max	47 - 68 db(A)
Assorbimento totale Total absorption	256 W

Filtro grassi alluminio incluso Grease aluminium Filter included

ACCESSORI ACCESSORIES	
Filtro carbone rigenerabile Regenerable charcoal filter	CFC0140423

MODELLI MODELS	
TUBE PRO IX/A/43	PRF0080075B
TUBE PRO BL MAT/A/43	PRF0090719B
TUBE PRO WH MAT/A/43	PRF0090720B



TONDA

ELICA DESIGN CENTER

60 - 90 cm
Filtrante Filtering
Acciaio inox
Stainless steel

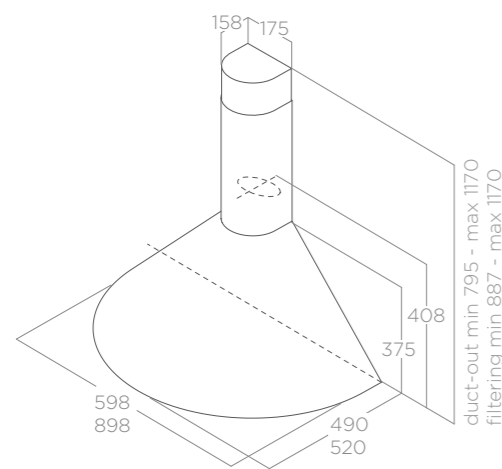

ILLUMINAZIONE LIGHTING	
Tipo Type	Led 2x3 W
Intensità Intensity	97 LUX
Temperatura Temperature	2700 K

PERFORMANCE PERFORMANCE	
Comandi Controls	Slider meccanico 3V 3S Mechanical slider
Portata massima Max airflow	355 m ³ /h
Livello sonoro min-max Noise level min-max	60 - 67 db(A)
Assorbimento totale Total absorption	146 W

Filtro grassi alluminio incluso Grease aluminium Filter included
Filtro carbone incluso Charcoal filter included
Camino incluso Chimney included

ACCESSORI ACCESSORIES	
Filtro carbone Charcoal filter	CFC0140124

MODELLI MODELS	
TONDA IX F/60	2938000C
TONDA IX F/90	2937999C



TAMAYA 2.0

ELICA DESIGN CENTER

60 - 90 cm
Aspirante Duct-out
Acciaio inox
Stainless steel

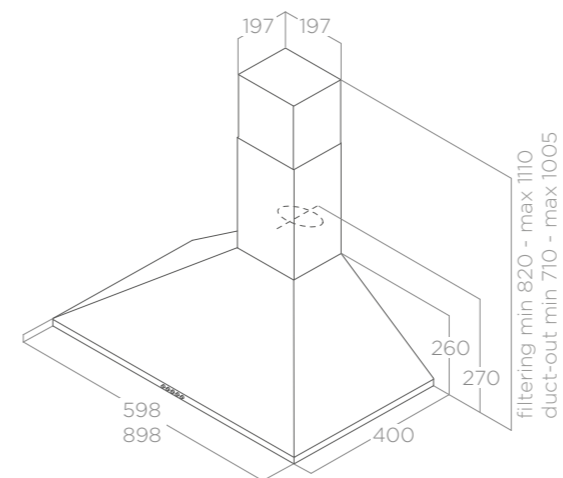

ILLUMINAZIONE LIGHTING	
Tipo Type	Led 2x2,5W
Intensità Intensity	381 LUX
Temperatura Temperature	3500K

PERFORMANCE PERFORMANCE	
Comandi Controls	Pulsantiera meccanica 3V 3S Mechanical push button
Portata massima Max airflow	435 m ³ /h
Livello sonoro min-max Noise level min-max	56 - 65 db(A)
Assorbimento totale Total absorption	145 W

Filtro grassi alluminio incluso Grease aluminium filter included
Camino incluso Chimney included

ACCESSORI ACCESSORIES	
Filtro carbone Charcoal filter	CFC0140343
Filtro carbone rigenerabile Regenerable charcoal filter	CFC0162221

MODELLI MODELS	
TAMAYA 2.0 IX/A/60	PRF0176616
TAMAYA 2.0 IX/A/90	PRF0176620



MISSY

ELICA DESIGN CENTER

60 - 90 cm
Aspirante Duct-out
Acciaio inox, nero
Stainless steel, black

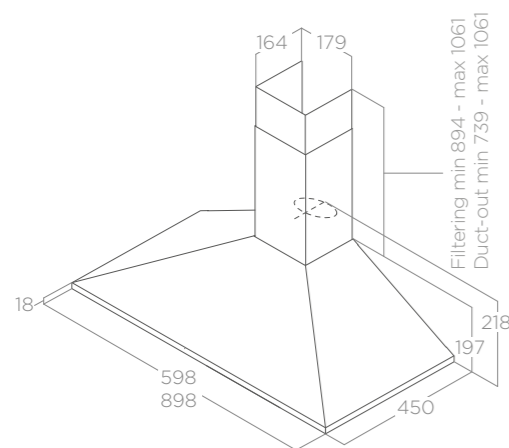

ILLUMINAZIONE LIGHTING	
Tipo Type	Led 2x3 W
Intensità Intensity	97 LUX
Temperatura Temperature	2700 K

PERFORMANCE PERFORMANCE	
Comandi Controls	Pulsantiera meccanica 3V 3S Mechanical push button
Portata massima Max airflow	395 m ³ /h
Livello sonoro min-max Noise level min-max	49 - 68 db(A)
Assorbimento totale Total absorption	96 W

Filtro grassi alluminio incluso Grease aluminium filter included
Camino incluso Chimney included

ACCESSORI ACCESSORIES	
Filtro carbone Charcoal filter	CFC0141497

MODELLI MODELS	
MISSY PB IX/A/60	PRF0091761B
MISSY PB IX/A/90	PRF0091763B
MISSY BL/A/60	PRF0151543
MISSY BL/A/90	PRF0151544



VEGA

ELICA DESIGN CENTER

60 - 90 cm
Filtrante Filtering
Acciaio inox
Stainless steel

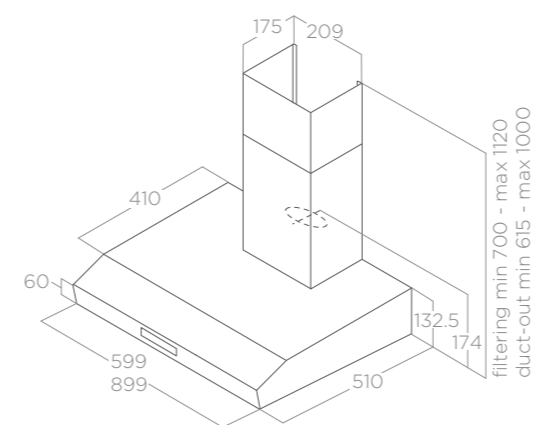

ILLUMINAZIONE LIGHTING	
Tipo Type	Led 2x3 W
Intensità Intensity	121 LUX
Temperatura Temperature	2700 K

PERFORMANCE PERFORMANCE	
Comandi Controls	Slider meccanico 3V 3S Mechanical slider
Portata massima Max airflow	265 m ³ /h
Livello sonoro min-max Noise level min-max	50 - 64 db(A)
Assorbimento totale Total absorption	101 W

Filtro grassi alluminio incluso Grease aluminium filter included
Filtro carbone incluso Charcoal filter included
Camino incluso Chimney included

ACCESSORI ACCESSORIES	
Filtro carbone Charcoal filter	CFC0140064
Kit camino +200 Chimney kit +200	KIT00778A
Kit camino +420 Chimney kit +420	KIT00779A

MODELLI MODELS	
VEGA 60 IX	56111002C
VEGA ST IX F/90	56111004B



ACUTA

ELICA DESIGN CENTER

100 cm

Filtrante Filtering
Acciaio inox, nero
Stainless steel, black

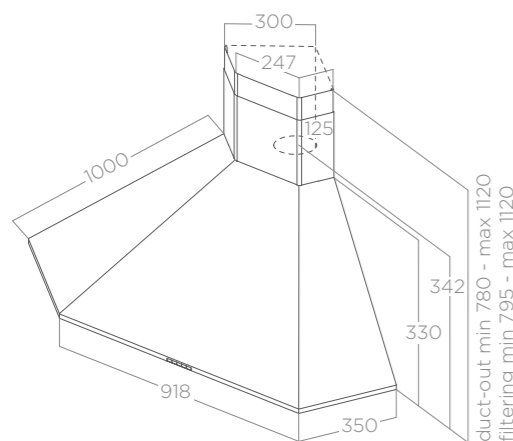
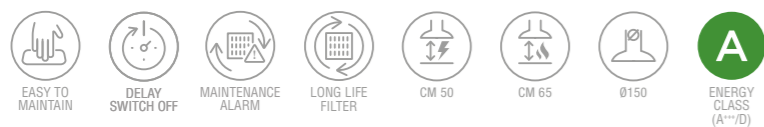

duct-out min 780 - max 1120
filtering min 795 - max 1120

ILLUMINAZIONE LIGHTING	
Tipo Type	Led 4x2,5 W
Intensità Intensity	441 LUX
Temperatura Temperature	3500 K
PERFORMANCE PERFORMANCE	
Comandi Controls	Pulsantiera elettronica 3V+I 3S+B Electronic push button
Portata intensiva Booster airflow	625 m ³ /h
Livello sonoro min-max Noise level min-max	46 - 60 db(A)
Assorbimento totale Total absorption	210 W
Filtro grassi alluminio incluso Grease aluminium filter included Filtro carbone incluso Charcoal filter included Camino incluso Chimney included	
ACCESSORI ACCESSORIES	
Filtro carbone Charcoal filter	CFC0140343
Filtro carbone rigenerabile Regenerable charcoal filter	CFC0162221
MODELLI MODELS	
ACUTA IX/F/100	PRF0121267A
ACUTA BL/F/100	PRF0127462A



HYDRA

ELICA DESIGN CENTER

100 cm

Filtrante Filtering
Acciaio inox
Stainless steel

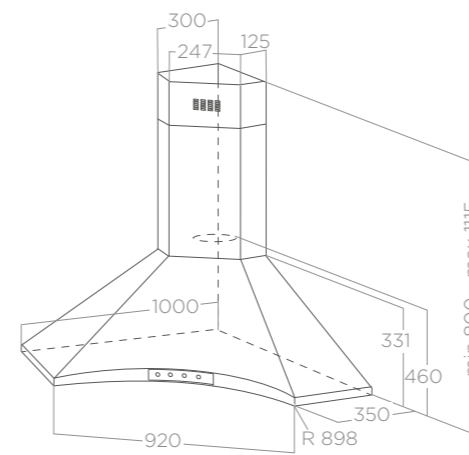

ILLUMINAZIONE LIGHTING	
Tipo Type	Led 4x2,5 W
Intensità Intensity	441 LUX
Temperatura Temperature	3500 K
PERFORMANCE PERFORMANCE	
Comandi Controls	Pulsantiera meccanica 3V 3S Mechanical push button
Portata massima Max airflow	496 m ³ /h
Livello sonoro min-max Noise level min-max	46 - 68 db(A)
Assorbimento totale Total absorption	170 W
Filtro grassi alluminio incluso Grease aluminium filter included Filtro carbone incluso Charcoal filter included Camino incluso Chimney included	
ACCESSORI ACCESSORIES	
Filtro carbone Charcoal filter	CFC0140122
MODELLI MODELS	
HYDRA ANG IX F/100	1608046A



SYNTHESIS

ELICA DESIGN CENTER

100 cm
Aspirante Duct-out
Acciaio inox + vetro
Stainless steel + glass

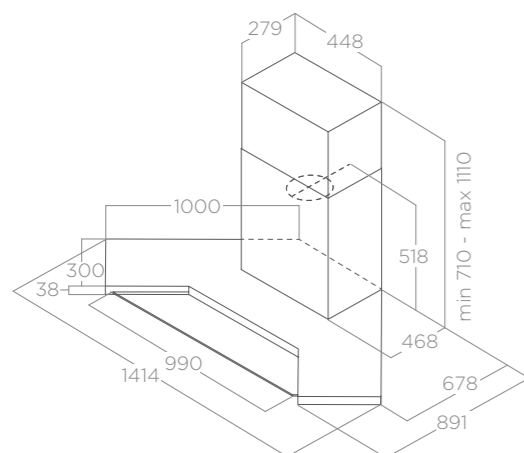
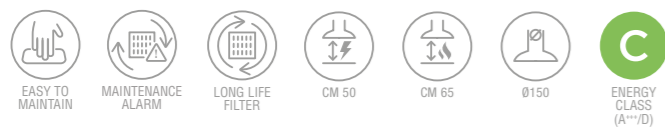

ILLUMINAZIONE LIGHTING	
Tipo Type	Led 4x2,5 W
Intensità Intensity	441 LUX
Temperatura Temperature	3500 K
PERFORMANCE PERFORMANCE	
Comandi Controls	Control ball 3V+I 3S+B Control ball
Portata intensiva Booster airflow	559 m ³ /h
Livello sonoro min-max Noise level min-max	44 - 63 db(A)
Assorbimento totale Total absorption	185 W

Filtro grassi alluminio incluso Grease aluminium Filter included
Camino incluso Chimney included

ACCESSORI ACCESSORIES	
Filtro carbone Charcoal filter	CFC0141529A
Filtro carbone rigenerabile Regenerable charcoal filter	CFC0141725A

MODELLI MODELS	
SYNTHESIS IX A/100	64214507A



RUBINO CORNER

ELICA DESIGN CENTER

100 cm
Aspirante Duct-out
Acciaio inox
Stainless steel

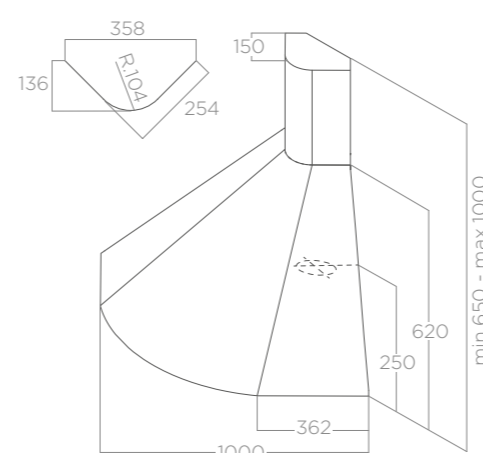

ILLUMINAZIONE LIGHTING	
Tipo Type	Led 2x3 W
Intensità Intensity	121 LUX
Temperatura Temperature	2700 K
PERFORMANCE PERFORMANCE	
Comandi Controls	Slider meccanico 3V 3S Mechanical slider
Portata massima Max airflow	603 m ³ /h
Livello sonoro min-max Noise level min-max	42 - 64 db(A)
Assorbimento totale Total absorption	186 W

Filtro grassi alluminio incluso Grease aluminium Filter included
Camino incluso Chimney included

ACCESSORI ACCESSORIES	
Filtro carbone Charcoal filter	CFC0140124

MODELLI MODELS	
RUBINO ANG IX A/100 IX	56811101C

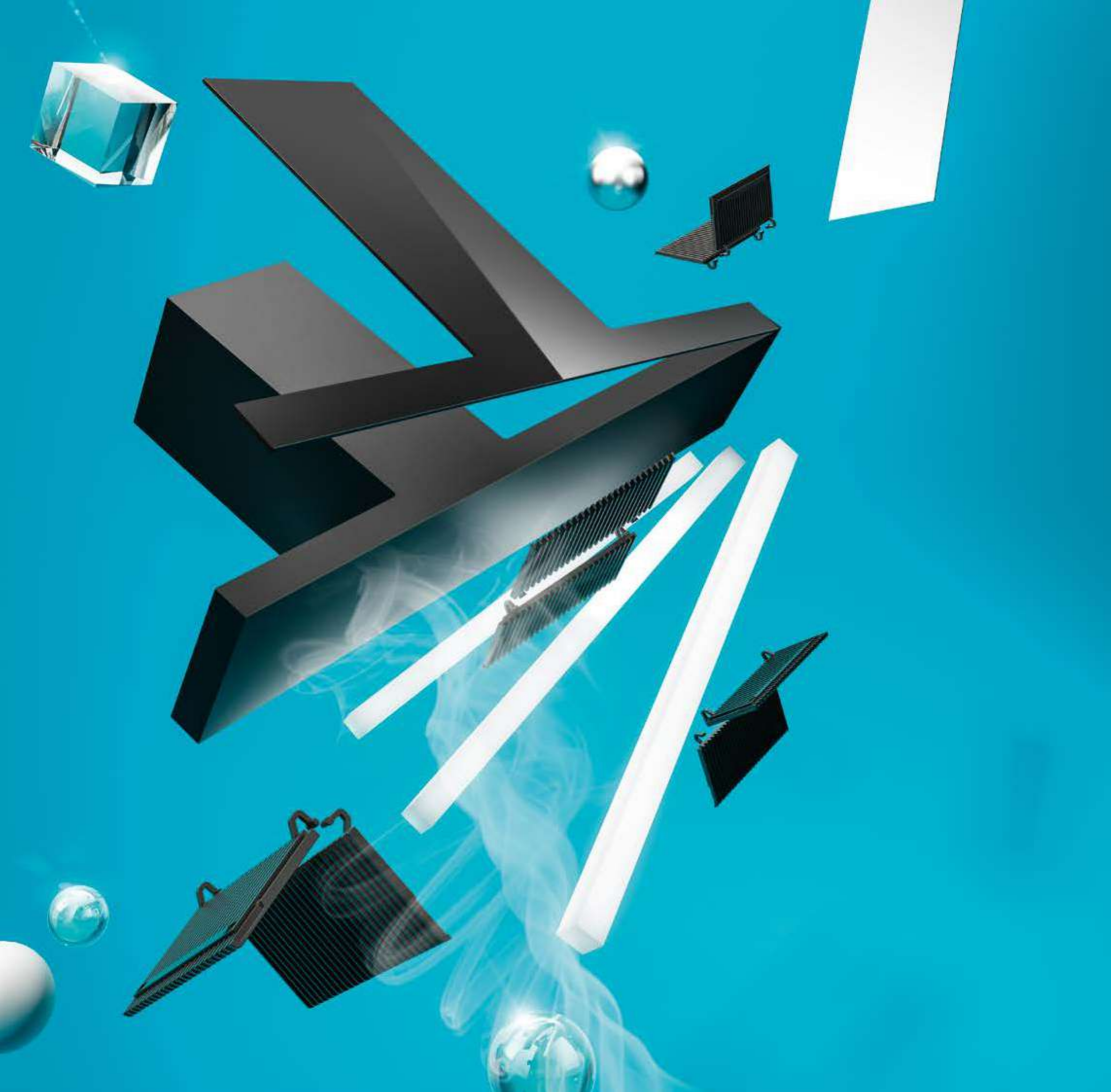

ISLAND MOUNTED

Le cappe a isola Elica sono veri e propri complementi in grado di riflettere il nostro personale stile e di dare carattere all'ambiente. Grazie alla loro estrema versatilità e modularità possono essere composte secondo i propri gusti, ponendosi come elemento distintivo e cuore della cucina. Legno, acciaio, vetro: molteplici possibilità che ci rendono i designer della nostra cucina, per uno stile unico. Progettate per emozionare.

Elica island hoods are genuine design accessories which reflect personal style and add character to the kitchen. Thanks to their extreme versatility and modularity, they can be composed based on your personal tastes and used as a statement feature in the kitchen. Wood, steel and glass: a whole host of possibilities which turn us into our own kitchen designers creating a unique style. Designed to thrill.

HAIKU ISLAND

DESIGN FABRIZIO CRISA





HAIKU ISLAND

DESIGN FABRIZIO CRISÀ



120x32 - 180x32 cm
Aspirante Duct-out
Vetro nero, Krion bianco, Acciaio inox
Black glass, white Krion, stainless steel



ILLUMINAZIONE LIGHTING	
Tipo Type	Strip Led 1x7 W
Intensità Intensity	365 LUX
Temperatura Temperature	3500 K

PERFORMANCE PERFORMANCE	
Comandi Controls	Pulsantiera elettronica 3V+2I 3S+2B Electronic push button
Portata intensiva Booster airflow	690 m ³ /h
Livello sonoro min-max Noise level min-max	34 - 51 db(A)
Assorbimento totale Total absorption	277 W

Filtro grassi alluminio incluso Grease aluminium filter included
Camino incluso Chimney included

ACCESSORI ACCESSORIES	
Filtro carbone Charcoal filter	CFC0141529A
Filtro carbone rigenerabile Regenerable charcoal filter	CFC0141725A

MODELLI MODELS	
HAIKU ISLAND IX/A/120	PRF0146279
HAIKU ISLAND IX/A/180	PRF0146280
HAIKU ISLAND BL/A/120	PRF0146286
HAIKU ISLAND BL/A/180	PRF0146287
HAIKU ISLAND WH/A/120	PRF0146290
HAIKU ISLAND WH/A/180	PRF0146291

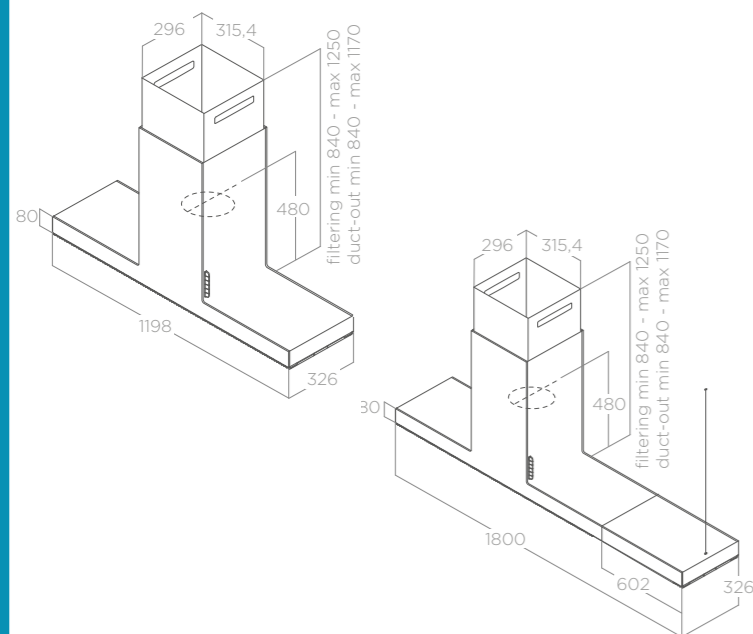

HAIKU ISLAND 32

DESIGN FABRIZIO CRISÀ



32x32 cm
Aspirante Duct-out
Vetro nero, Krion bianco, Acciaio inox
Black glass, white Krion, stainless steel



ILLUMINAZIONE LIGHTING	
Tipo Type	Strip Led 1x7 W
Intensità Intensity	365 LUX
Temperatura Temperature	3500 K

PERFORMANCE PERFORMANCE	
Comandi Controls	Pulsantiera elettronica 3V+2I 3S+2B Electronic push button
Portata intensiva Booster airflow	690 m ³ /h
Livello sonoro min-max Noise level min-max	34 - 51 db(A)
Assorbimento totale Total absorption	277 W

Filtro grassi alluminio incluso Grease aluminium filter included
Camino incluso Chimney included

ACCESSORI ACCESSORIES	
Filtro carbone Charcoal filter	CFC0141529A
Filtro carbone rigenerabile Regenerable charcoal filter	CFC0141725A

MODELLI MODELS	
HAIKU ISLAND IX/A/32	PRF0146277
HAIKU ISLAND BL/A/32	PRF0146285
HAIKU ISLAND WH/A/32	PRF0146289

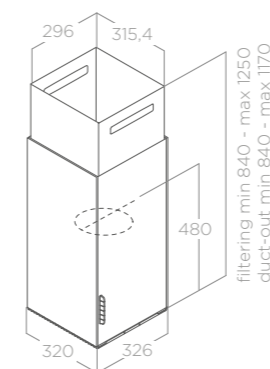

BIO ISLAND

DESIGN FABRIZIO CRISÀ





BIO ISLAND

DESIGN FABRIZIO CRISÀ



120x52 cm
Aspirante Duct-out
Rovere naturale + bianco effetto soft touch
Natural oak + white soft touch effect

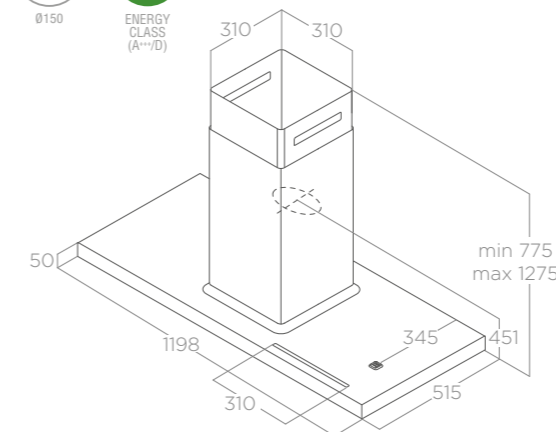
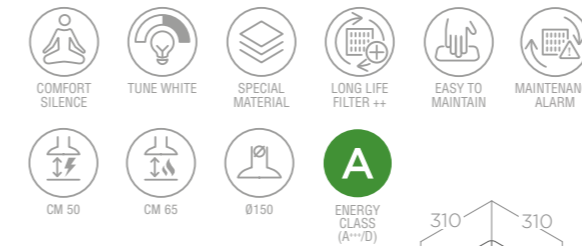

La cornice è un multistrato con rivestimento di 10 mm di rovere massello per evitare il fenomeno della dilatazione dovuta allo shock termico. Nella sua parte superiore è presente un supporto per tablet e smartphone e una presa USB a doppia porta. Bio è altamente versatile grazie alla mensola da 60 cm che permette di completare esteticamente il prodotto a proprio piacimento come estensione del corpo cappa o come elemento di arredo indipendente.
The frame is made from plywood with a 10 mm solid oak finish to prevent expansion phenomena caused by thermal shock. The top part features a support for tablets and smartphones, along with a double USB port. Bio is highly versatile thanks to its 60 cm shelf, allowing the product to be aesthetically completed however one prefers, whether as an extension of the hood body or independent furnishing element.

ILLUMINAZIONE LIGHTING

Tipo Type	Strip Led 2x7 W
Intensità Intensity	113 LUX
Temperatura Temperature	2700 - 6500 K

PERFORMANCE PERFORMANCE

Comandi Controls	Pulsantiera elettronica 3V+2I 3S+2B Electronic push button
Portata intensiva Booster airflow	720 m ³ /h
Livello sonoro min-max Noise level min-max	35 - 58 db(A)
Assorbimento totale Total absorption	257 W

Filtro grassi alluminio incluso Grease aluminium filter included
Camino incluso Chimney included

ACCESSORI ACCESSORIES

Kit prima installazione filtrante HP First installation HP filtering kit	KIT0160440
Filtro carbone rigenerabile Regenerable charcoal filter	CFC0141725A
Filtro carbone rigenerabile HP Regenerable charcoal HP filter	CFC0140091
Kit mensola isola rovere 60cm + 2 cavi Oak island shelf kit 60cm + 2 cables	KIT0120947
Kit 2 cavi mensola (1,7m) Cables shelf kit 2pcs (1,7m)	KIT0120948
Radiocomando Design bianco White Design remote control	KIT0121468
Radiocomando Design nero Black Design remote control	KIT0121469

MODELLI MODELS

BIO ISLAND WH/A/120X53 ROVERE	PRF0148081
-------------------------------	------------



METEORITE ISLAND

DESIGN FABRIZIO CRISÀ

120x60 cm
Aspirante Duct-out
Acciaio inox + vetro nero
Stainless steel + black glass

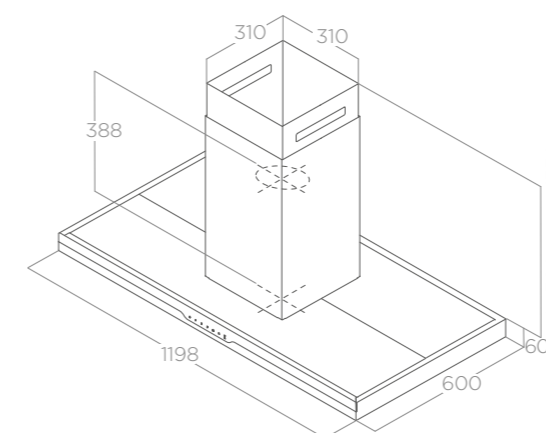
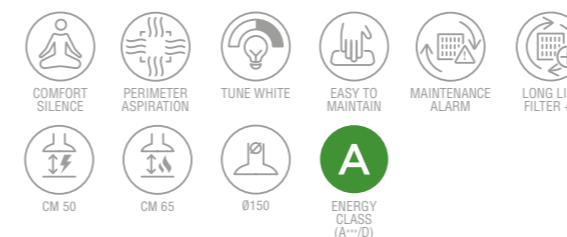

ILLUMINAZIONE LIGHTING

Tipo Type	Strip Led 2x7 W
Intensità Intensity	113 LUX
Temperatura Temperature	2700 - 6500 K

PERFORMANCE PERFORMANCE

Comandi Controls	Touch control capacitivo 3V+2I 3S+2B Capacitive touch control
Portata intensiva Booster airflow	700 m ³ /h
Livello sonoro min-max Noise level min-max	32 - 56 db(A)
Assorbimento totale Total absorption	257 W

Filtro grassi alluminio incluso Grease aluminium filter included
Camino incluso Chimney included

ACCESSORI ACCESSORIES

Kit prima installazione filtrante HP First installation HP filtering kit	KIT0160440
Filtro carbone rigenerabile Regenerable charcoal filter	CFC0141725A
Filtro carbone rigenerabile HP Regenerable charcoal HP filter	CFC0140091

MODELLI MODELS

METEORITE ISLAND IX/A/120x60	PRF0148122
------------------------------	------------



MOON ISLAND

ELICA DESIGN CENTER

175x73 cm
Filtrante Filtering
Acciaio Inox
 Stainless steel

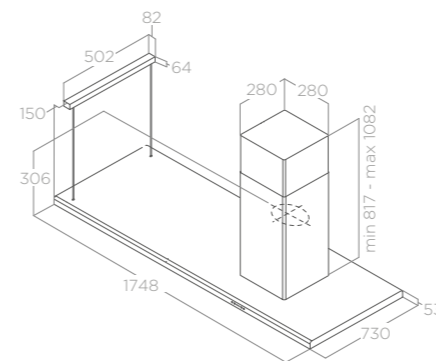

ILLUMINAZIONE LIGHTING

Tipo Type	Neon 4x21 W
Intensità Intensity	176 LUX
Temperatura Temperature	6500 K

PERFORMANCE PERFORMANCE

Comandi Controls	Pulsantiera elettronica 3V+I 3S+B Electronic push button
Portata intensiva Booster airflow	690 m ³ /h
Livello sonoro min-max Noise level min-max	52 - 68 db(A)
Assorbimento totale Total absorption	344 W

Filtro grassi alluminio incluso Grease aluminium Filter included
Filtro carbone incluso Charcoal filter included
Camino incluso Chimney included

ACCESSORI ACCESSORIES

Filtro carbone Charcoal filter	CFC0141529A
Filtro carbone rigenerabile Regenerable charcoal filter	CFC0141725A
Kit prolunga installazione isola H15 per controsoffitto Island installation extension kit H15 (false ceiling)	KIT01600

MODELLI MODELS

MOON ISLAND IX/F/180	PRF0079552A
----------------------	-------------



ADÉLE ISLAND

DESIGN FABRIZIO CRISÀ

90x60 cm

Aspirante Duct-out

Acciaio inox + vetro nero, nero effetto soft touch + vetro nero

Stainless steel + black glass, black soft touch effect + black glass



EASY TO MAINTAIN



MAINTENANCE ALARM



LONG LIFE FILTER



CM 50



CM 65



Ø150



ENERGY CLASS (A~D)

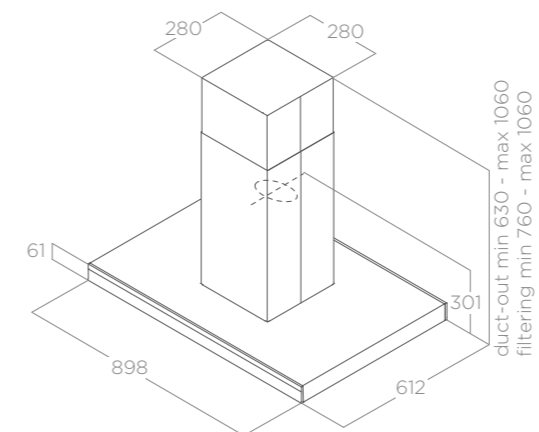

ILLUMINAZIONE LIGHTING	
Tipo Type	Strip Led 2x7 W
Intensità Intensity	309 LUX
Temperatura Temperature	3000 K

PERFORMANCE PERFORMANCE	
Comandi Controls	Touch control capacitivo 3V+I 3S+B Capacitive touch control
Portata intensiva Booster airflow	770 m ³ /h
Livello sonoro min-max Noise level min-max	55 - 69 db(A)
Assorbimento totale Total absorption	277 W

Filtro grassi alluminio incluso Grease aluminium filter included
Camino incluso Chimney included

ACCESSORI ACCESSORIES	
Filtro carbone Charcoal filter	CFC0141529A
Filtro carbone rigenerabile Regenerable charcoal filter	CFC0141725A
Kit prolunga installazione isola H15 per controsoffitto Island installation extension kit H15 (false ceiling)	KIT01600

MODELLI MODELS	
ADÉLE IS BLIX/A/90 X 60	PRF0167313
ADÉLE IS BL MAT/A/90 X 60	PRF0167316



JOY ISLAND

ELICA DESIGN CENTER

90x61 cm
Aspirante Duct-out
Acciaio inox + vetro nero, acciaio inox + vetro bianco
Stainless steel + black glass, stainless steel + white glass

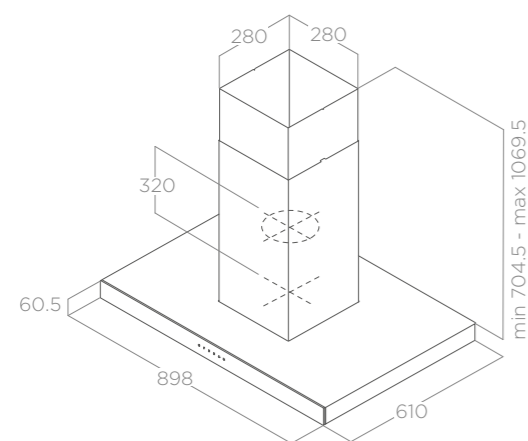

ILLUMINAZIONE LIGHTING	
Tipo Type	Led 4x2,5 W
Intensità Intensity	761 LUX
Temperatura Temperature	3500 K

PERFORMANCE PERFORMANCE	
Comandi Controls	Touch control capacitivo 3V+I 3S+B Capacitive touch control
Portata intensiva Booster airflow	713 m³/h
Livello sonoro min-max Noise level min-max	51 - 69 db(A)
Assorbimento totale Total absorption	270 W

Filtro grassi alluminio incluso Grease aluminium filter included
Camino incluso Chimney included

ACCESSORI ACCESSORIES	
Filtro carbone Charcoal filter	CFC0141529A
Filtro carbone rigenerabile Regenerable charcoal filter	CFC0141725A
Kit prolunga installazione isola H15 per controsoffitto Island installation extension kit H15 (false ceiling)	KIT01600

MODELLI MODELS	
JOY ISLAND BLIX/A/90	PRF0104628A
JOY ISLAND WHIX/A/90	PRF0104629A



GALAXY ISLAND

ELICA DESIGN CENTER

90x45 cm
Aspirante Duct-out
Acciaio inox + vetro nero, acciaio inox + vetro bianco
Stainless steel + black glass, stainless steel + white glass

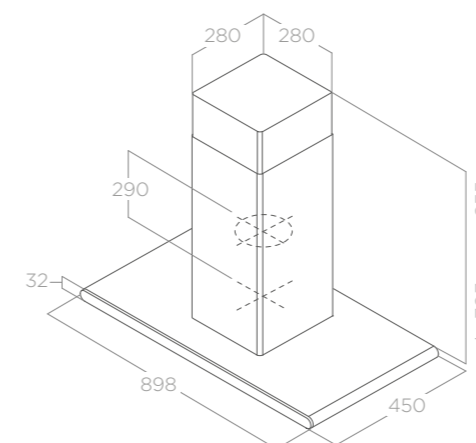

ILLUMINAZIONE LIGHTING	
Tipo Type	Led 4x2,5 W
Intensità Intensity	290 LUX
Temperatura Temperature	3500 K

PERFORMANCE PERFORMANCE	
Comandi Controls	Touch control capacitivo 3V+I 3S+B Capacitive touch control
Portata intensiva Booster airflow	647 m³/h
Livello sonoro min-max Noise level min-max	52 - 69 db(A)
Assorbimento totale Total absorption	270 W

Filtro grassi alluminio incluso Grease aluminium filter included
Camino incluso Chimney included

ACCESSORI ACCESSORIES	
Filtro carbone Charcoal filter	CFC0141529A
Filtro carbone rigenerabile Regenerable charcoal filter	CFC0141725A
Kit prolunga installazione isola H15 per controsoffitto Island installation extension kit H15 (false ceiling)	KIT01600

MODELLI MODELS	
GALAXY ISLAND BLIX/A/90x45	PRF0017852B
GALAXY ISLAND WHIX/A/90x45	PRF0019192B



IKONA

DESIGN FABRIZIO CRISÀ

60x44cm
Aspirante Duct-out
Nero effetto soft touch Black soft touch effect

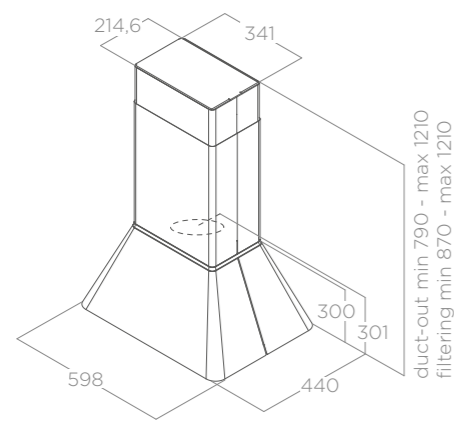
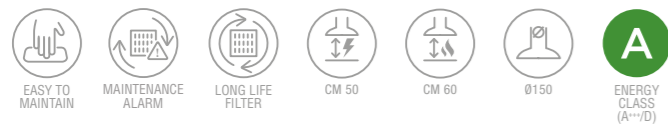

ILLUMINAZIONE LIGHTING	
Tipo Type	STRIP LED 1x7W
Intensità Intensity	365 LUX
Temperatura Temperature	3500 K

PERFORMANCE PERFORMANCE	
Comandi Controls	Touch control capacitivo 3V+I 3S+B Capacitive touch control
Portata intensiva Booster airflow	605 m ³ /h
Livello sonoro min-max Noise level min-max	47 - 62 db(A)
Assorbimento totale Total absorption	207 W

Filtro grassi alluminio incluso Grease aluminium filter included

ACCESSORI ACCESSORIES	
Filtro carbone Charcoal filter	CFC0140343
Filtro carbone rigenerabile Regenerable charcoal filter	CFC0162221

MODELLI MODELS	
IKONA BL MAT/A/60	PRF0164784



THIN ISLAND

DESIGN FABRIZIO CRISÀ

120x57 cm
Aspirante Duct-out
Acciaio inox Stainless steel

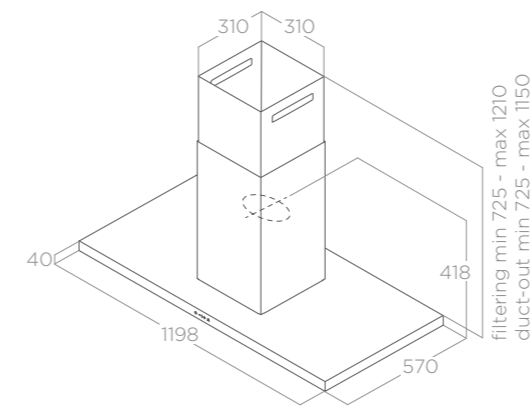

ILLUMINAZIONE LIGHTING	
Tipo Type	Strip Led 2x7 W
Intensità Intensity	253 LUX
Temperatura Temperature	3500 K

PERFORMANCE PERFORMANCE	
Comandi Controls	Touch control infrarossi 3V+2I 3S+2B Infrared touch control
Portata intensiva Booster airflow	680 m ³ /h
Livello sonoro min-max Noise level min-max	34 - 52 db(A)
Assorbimento totale Total absorption	284 W

Filtro grassi alluminio incluso Grease aluminium filter included
Camino incluso Chimney included

ACCESSORI ACCESSORIES	
Filtro carbone Charcoal filter	CFC0141529A
Filtro carbone rigenerabile Regenerable charcoal filter	CFC0141725A

MODELLI MODELS	
THIN ISLAND IX/A/120	PRF0144973



SPOT PLUS ISLAND

ELICA DESIGN CENTER

90x60 cm
Aspirante Duct-out
Acciaio inox Stainless steel

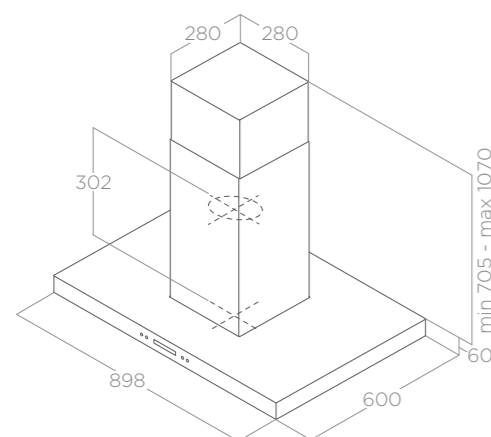

ILLUMINAZIONE LIGHTING

Tipo Type Led 4x2,5 W
Intensità Intensity 761 LUX
Temperatura Temperature 4000 K

PERFORMANCE PERFORMANCE

Comandi Controls Pulsantiera elettronica con LCD 3V+I
3S+B Electronic push button with LCD
Portata intensiva Booster airflow 620 m³/h
Livello sonoro min-max Noise level min-max 52 - 67 db(A)
Assorbimento totale Total absorption 210 W

Filtro grassi alluminio incluso Grease aluminium filter included
Camino incluso Chimney included

ACCESSORI ACCESSORIES

Filtro carbone Charcoal filter CFC0141529A
Filtro carbone rigenerabile Regenerable charcoal filter CFC0141725A
Kit prolunga installazione isola H15 per controsoffitto Island installation extension kit H15 (false ceiling) KIT01600

MODELLI MODELS

SPOT PLUS ISLAND IX/A/90 PRF0097375A



TRIBE ISLAND

ELICA DESIGN CENTER

90x60 cm
Aspirante Duct-out
Acciaio inox + vetro
Stainless steel + glass

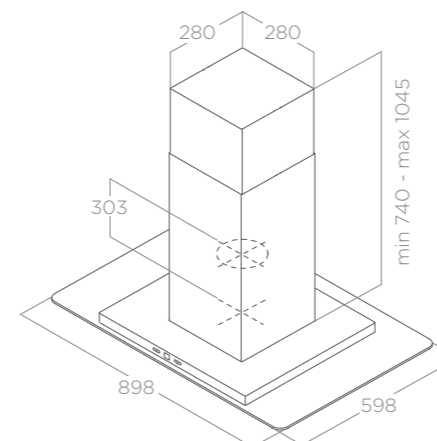

ILLUMINAZIONE LIGHTING

Tipo Type Led 2x2,5 W
Intensità Intensity 381 LUX
Temperatura Temperature 3000 K

PERFORMANCE PERFORMANCE

Comandi Controls Pulsantiera elettronica con display 3V+I
3S+B Electronic push button with display
Portata intensiva Booster airflow 600 m³/h
Livello sonoro min-max Noise level min-max 48 - 64 db(A)
Assorbimento totale Total absorption 205 W

Filtro grassi alluminio incluso Grease aluminium filter included
Camino incluso Chimney included

ACCESSORI ACCESSORIES

Filtro carbone Charcoal filter CFC0141529A
Filtro carbone rigenerabile Regenerable charcoal filter CFC0141725A
Kit prolunga installazione isola H15 per controsoffitto Island installation extension kit H15 (false ceiling) KIT01600

MODELLI MODELS

TRIBE A ISLAND IX/A/90X60 PRF0150293



REEF ISLAND

ELICA DESIGN CENTER

90x60 cm
Aspirante Duct-out
Acciaio inox + vetro
Stainless steel + glass

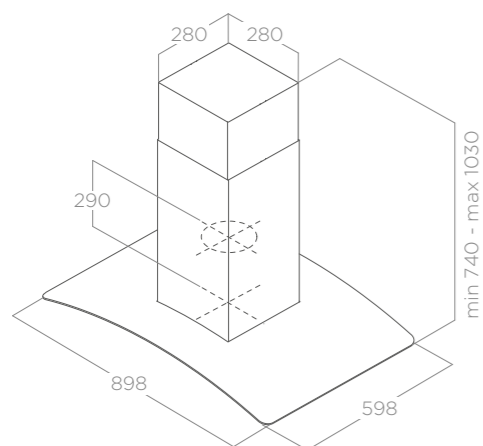
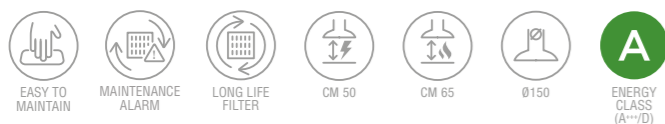

ILLUMINAZIONE LIGHTING	
Tipo Type	Led 2x2,5 W
Intensità Intensity	381 LUX
Temperatura Temperature	3000 K
PERFORMANCE PERFORMANCE	
Comandi Controls	Pulsantiera elettronica con display 3V+I 3S+B Electronic push button with display
Portata intensiva Booster airflow	600 m ³ /h
Livello sonoro min-max Noise level min-max	48 - 64 db(A)
Assorbimento totale Total absorption	205 W
Filtro grassi alluminio incluso Grease aluminium filter included Camino incluso Chimney included	
ACCESSORI ACCESSORIES	
Filtro carbone Charcoal filter	CFC0141529A
Filtro carbone rigenerabile Regenerable charcoal filter	CFC0141725A
Kit prolunga installazione isola H15 per controsoffitto Island installation extension kit H15 (false ceiling)	KIT01600
MODELLI MODELS	
REEF A ISLAND IX/A/90X60	PRF0150290



ZENITH

ELICA DESIGN CENTER

Ø33 cm
Aspirante Duct-out
Acciaio inox
Stainless steel

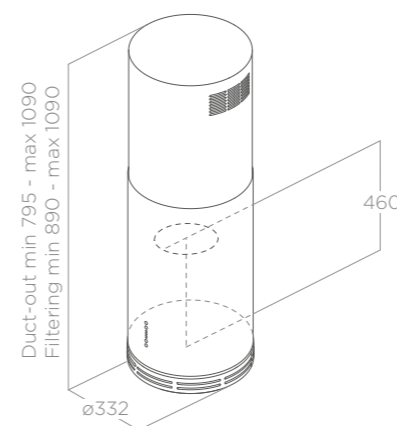

ILLUMINAZIONE LIGHTING	
Tipo Type	Led 3x2,5 W
Intensità Intensity	571 LUX
Temperatura Temperature	3500 K
PERFORMANCE PERFORMANCE	
Comandi Controls	Pulsantiera elettronica 3V+I 3S+B Electronic push button
Portata intensiva Booster airflow	650 m ³ /h
Livello sonoro min-max Noise level min-max	49 - 63 db(A)
Assorbimento totale Total absorption	262 W
Filtro grassi alluminio incluso Grease aluminium Filter included Camino incluso Chimney included	
ACCESSORI ACCESSORIES	
Filtro carbone Charcoal filter	CFC0141529A
Filtro carbone rigenerabile Regenerable charcoal filter	CFC0141725A
MODELLI MODELS	
ZENITH II IX/A/33	PRF0183060



TUBE PRO ISLAND BL



TUBE PRO ISLAND WH



TUBE PRO ISLAND IX

TUBE PRO ISLAND

ELICA DESIGN CENTER

Ø43 cm

Aspirante Duct-out

Acciaio inox, nero effetto soft touch, bianco effetto soft touch
Stainless steel, black soft touch effect, white soft touch effect

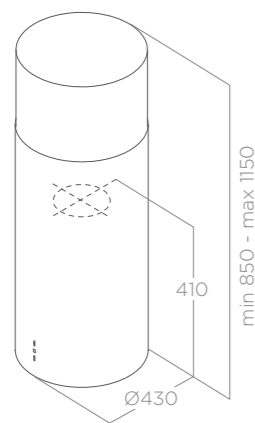

ILLUMINAZIONE LIGHTING

Tipo Type	Led 2x3 W
Intensità Intensity	457 LUX
Temperatura Temperature	2700 K

PERFORMANCE PERFORMANCE

Comandi Controls	Pulsantiera meccanica 3V 3S Mechanical push button
Portata massima Max airflow	603 m³/h
Livello sonoro min-max Noise level min-max	47 - 68 db(A)
Assorbimento totale Total absorption	256 W

Filtro grassi alluminio incluso Grease aluminium Filter included
Camino incluso Chimney included

ACCESSORI ACCESSORIES

Filtro carbone rigenerabile Regenerable charcoal filter	CFC0140423
Kit prolunga installazione isola H15 per controsoffitto Island installation extension kit H15 (false ceiling)	KIT01600

MODELLI MODELS

TUBE PRO ISLAND IX/A/43	PRF0044794B
TUBE PRO ISLAND BL MAT/A/43	PRF0090717B
TUBE PRO ISLAND WH MAT/A/43	PRF0090718B

KUADRA ISLAND

ELICA DESIGN CENTER

43x43 - 60x43 cm

Aspirante Duct-out

Acciaio inox
Stainless steel

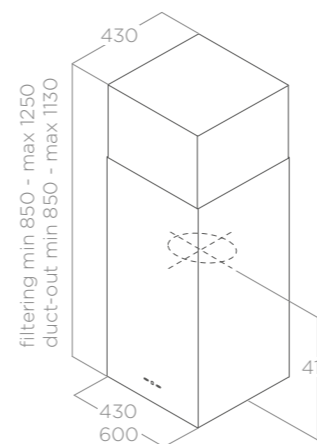

ILLUMINAZIONE LIGHTING

Tipo Type	Led 2x2,5 W
Intensità Intensity	457 LUX
Temperatura Temperature	2700 K

PERFORMANCE PERFORMANCE

Comandi Controls	Pulsantiera elettronica con display 3V+I 3S+B Electronic push button with display
Portata intensiva Booster airflow	496 m³/h
Livello sonoro min-max Noise level min-max	48 - 62 db(A)
Assorbimento totale Total absorption	256 W

Filtro grassi alluminio incluso Grease aluminium Filter included
Camino incluso Chimney included

ACCESSORI ACCESSORIES

Filtro carbone rigenerabile Regenerable charcoal filter	CFC0140423
Kit prolunga installazione isola H15 per controsoffitto Island installation extension kit H15 (false ceiling)	KIT01600

MODELLI MODELS

KUADRA ISLAND IX/A/43	PRF0007655A
KUADRA ISLAND IX/A/60	PRF0007028A



CEILING

Vogliamo una casa che ci rispecchi, in cui ogni singolo accessorio sia espressione del nostro io. Dal cavo colorato, alla lampadina d'atmosfera. Vogliamo soluzioni in grado di stupirci e di stupire.

Le cappe ceiling Elica sono la soluzione discreta che può scomparire nel soffitto o diventare protagonista grazie alla luce. Un progetto di architettura e illuminotecnica che unisce le migliori tecnologie di aspirazione a un sapiente utilizzo della luce in casa.

We want a home that reflects who we are, in which every single accessory is an expression of ourselves. From the coloured cable to the atmospheric light. We want solutions that surprise us and surprise others.

Elica ceiling hoods are the solution that can discretely disappear into the ceiling or become a key lighting feature. An architectural and lighting project that combines the best extraction technology with an intelligent use of light in the home.

UN NUOVO PUNTO DI LUCE E DI VISTA A NEW POINT OF LIGHT AND VIEW



I più recenti progetti di architettura d'interni vedono il progressivo abbandono della tradizionale cucina intesa come locale a sé stante, in favore di una soluzione a vista inserita all'interno del living. Questo cambio di paradigma ha rivoluzionato anche la progettazione degli elettrodomestici, che hanno beneficiato di una importante trasformazione in termini di design estetico e funzionale.

In uno scenario dove poniamo molta attenzione alla perfetta integrazione tra tutti gli elementi che arredano un unico ambiente, la luce assume un grande valore nel garantire equilibrio e omogeneità agli spazi. La visione di insieme è così fluida e ininterrotta.

The latest interior architectural projects have seen the gradual shift away from traditional kitchens in terms of just a room, in favour of an open-space solution included in a living area. This change of layout has also revolutionised the design of electrical appliances which have benefited from a major transformation in terms of aesthetic and functional design.

In a setting in which significant importance is placed on the perfect integration between all the elements which furnish a single area, light becomes paramount in guaranteeing balance and uniformity to spaces. The overall vision thus becomes fluid and seamless.

Le cappe ceiling Elica sono disegnate per integrarsi perfettamente nelle superfici in cui vengono inserite. Nei ricercati modelli proposti, la luce gioca un ruolo fondamentale all'interno del progetto architettonico complessivo: i pannelli luminosi disegnano lo spazio, creando non solo atmosfere personalizzate, ma impalpabili volumi aerei, che possono diventare protagonisti dell'ambiente o sparire discreti a soffitto quando spenti. Come vere finestre a soffitto, le cappe Elica assicurano elevate performance di aspirazione e la migliore illuminazione possibile, grazie all'utilizzo di led dimmerabili e alla funzione Tune White, che permette di regolare il colore della luce in base ai propri gusti e necessità.

A comporre la gamma ceiling, prodotti dall'alto valore tecnologico ed estetico: Hilight, dal design elegante e moderno, Illusion, la soluzione rivestibile pensata per scomparire come una vera illusione nel soffitto, Skydome, con le sue linee pulite e discrete e caratterizzata dal grande pannello luminoso e Lullaby, un vero progetto di architettura, materia e luce che diventa protagonista della cucina.



Elica ceiling extractor hoods are designed to integrate seamlessly into the surfaces in which they are inserted. In the sophisticated models on offer, light plays a fundamental role in the overall architectural project. The illuminated panels outline the space, creating not just personalised atmospheres, but imperceptible aerial volumes which can become a signature feature in the room or blend discretely into the ceiling when not in use. Like real windows in the ceiling, Elica hoods provide exceptional extraction performance and the best lighting possible through the use of dimmer lights and the Tune White function

which allows the colour of the light to be adjusted based on personal tastes and requirements.

The ceiling range consists of products with a high technological and aesthetic value: Hilight, with its elegant and modern design; Illusion, the paintable solution which gives the illusion of disappearing into the ceiling; Skydome, with its clean, discrete lines featuring signature large illuminated panel and Lullaby, an authentic architectural project featuring material and light which stamp their mark on the kitchen.

S.E.I. SYSTEM

Grazie al sistema brevettato Super Easy Installation, inoltre, per montare il prodotto bastano pochi e semplici passaggi, che assicurano totale sicurezza e l'integrità della controsoffittatura.

Thanks to the patented Super Easy Installation system, just a few simple steps are all that it takes to complete the safe installation of the hood without affecting the false ceiling.

Avvicinare il prodotto al vano nel controsoffitto.
Bring the product to the compartment in the false ceiling.

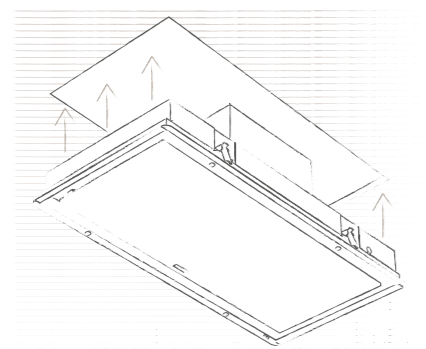

Spingere il prodotto nell'apertura praticata.
Push the product into the practical opening.

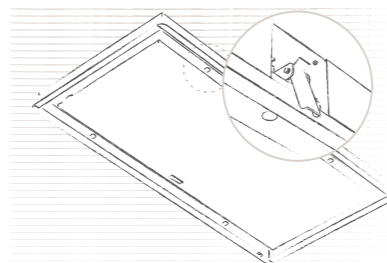

Stringere le viti per il definitivo fissaggio del prodotto.
Tighten the screws to definitively fix the product.

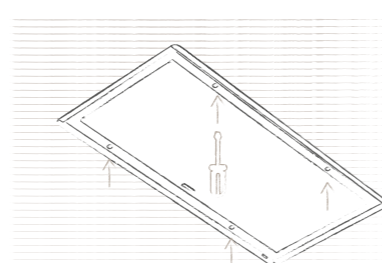

Le staffe bloccano il prodotto nel controsoffitto.
The brackets hold the product in the false ceiling.

Disponibile per i modelli: Illusion, Skydome, Hilight Glass e Hilight-X.

Available for models: Illusion, Skydome, Hilight Glass and Hilight-X.

INSTALLAZIONE SALVASPAZIO SPACE-SAVING INSTALLATION

INSTALLAZIONE H30
H30 INSTALLATION



INSTALLAZIONE H16
H16 INSTALLATION



Il potente cuore aspirante rimane integrato nel controsoffitto e assicura un'elevata captazione dei fumi. Nate per essere installate ovunque, le cappe ceiling di Elica si adattano perfettamente anche ai soffitti meno alti: sono infatti disponibili in duplice altezza, da 30 cm o da 16 cm.

The powerful extractor fan is integrated in the false ceiling and ensures an excellent level of fume extraction. Designed to be installed anywhere, Elica ceiling hoods adapt perfectly even to lower ceilings. They are, in fact, available in two heights, 30 cm and 16 cm.

ACCESSORI LUCE LIGHTING ACCESSORIES

Le cappe ceiling Elica sono dotate di lampade led ad alta intensità. Nella maggior parte dei modelli è possibile regolare il livello di luminosità e la tonalità di bianco preferita, in base al momento della giornata o delle proprie necessità. Una luce più fredda sarà perfetta per preparare al meglio le portate, mentre potremo sceglierne una più calda per ricreare un'atmosfera intima durante una cena.

Elica ceiling hoods are fitted with high-intensity LED lights. The luminosity and white tone can be adjusted on all the models depending on the time of day or personal requirements. A colder light is perfect when preparing meals while a warmer light is just what you need to create an intimate atmosphere during dinner.

Come un vero e proprio lampadario, la cappa può essere comandata anche con interruttore a parete dell'impianto domestico o con un telecomando che potremo tenere appeso a parete attraverso un pratico magnete.

Just like a real ceiling light, the hood can also be controlled with a wall switch or a remote control which can be attached to the wall with a handy magnet.



Possibilità di collegare al prodotto qualsiasi tipo di lampada disponibile sul mercato. Disponibile per i modelli: Lullaby, Illusion, Skydome et Hilight Glass.

Any type of commercially available light can also be connected. Available for models: Lullaby, Illusion, Skydome en Hilight Glass.



LULLABY
DESIGN FABRIZIO CRISÀ



LULLABY

DESIGN FABRIZIO CRISÀ
ELICA CONNECT



120x65 cm
Aspirante/Filtrante Duct-out/Filtering
WH WOOD: legno laccato bianco + acciaio inox
WOOD: rovere naturale + bianco effetto soft touch
WH WOOD: white lacquered wood + stainless steel
WOOD: natural oak + White soft touch effect

Modello installabile senza necessità di interventi su cartongesso o tubazioni aggiuntive (Lullaby Filtrante). Il pannello luminoso centrale full LED è avvolto in una cornice in legno di rovere invecchiato disponibile in due finiture. Disponibili come accessori le mensole in coordinato e possibilità di collegare al prodotto qualsiasi tipo di lampada disponibile sul mercato. The model can be installed without the need for work on plasterboard or additional pipes (Lullaby Filter). The central full LED light panel is surrounded by a distressed oak frame, available in two finishes. The coordinated shelves are available as accessories and any type of commercially available light can also be connected.

ASPIRANTE

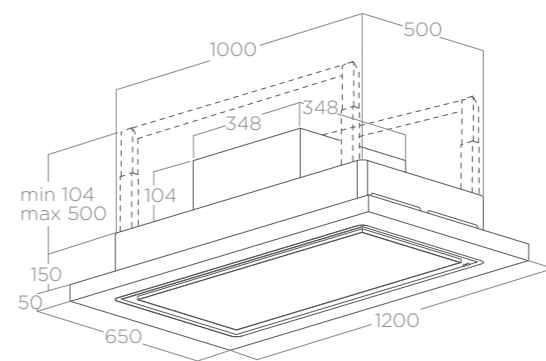

FILTRANTE

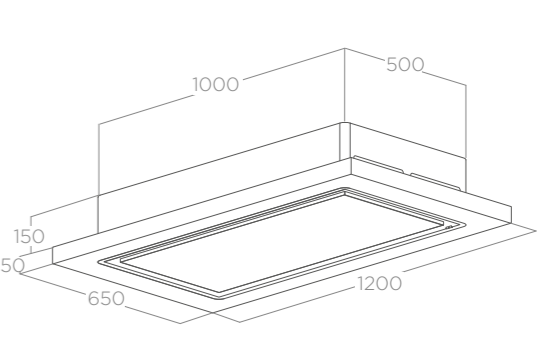

FALSE CEILING CUT 470X960



ILLUMINAZIONE LIGHTING	
Tipo Type	Led Panel 28W
Intensità Intensity	1683 LUX
Temperatura Temperature	2400 - 5000 K

PERFORMANCE PERFORMANCE		
Comandi Controls	Aspirante Duct-out	Filtrante Filtering
	Radiocomando 3V + 2I 3S + 2B Remote control	Radiocomando 3V + 2I 3S + 2B Remote control
Portata intensiva Booster airflow	770 m³/h	470 m³/h
Livello sonoro min-max Noise level min-max	40 - 53 db(A)	46 - 64 db(A)
Assorbimento totale Total absorption	298 W	568 W

- Filtro grassi alluminio incluso Grease aluminium filter included
- Filtro in ceramica anti-odori rigenerabile HP incluso (*) HP regenerable anti-odor ceramic filter included (*)
- Radiocomando incluso Remote control included

Modello non soggetto a certificazione energetica obbligatoria. (*)
Model not subject to compulsory energy certification. (*)

ACCESSORI ACCESSORIES	
Filtro in ceramica anti-odori rigenerabile HP HP regenerable anti-odor ceramic filter	KIT0147861A
Radiocomando Design bianco White Design remote control	KIT0121468
Radiocomando Design nero Black Design remote control	KIT0121469
Kit mensola bianca White shelf kit	KIT0147859
Kit mensola rovere Oak shelf kit	KIT0147858
Kit filtrante a bordo H30 On board filtering kit H30	KIT0148449
Kit filtrante high performance prima installazione H16-H30 INOX High performance first installation filtering kit H16-H30 INOX	KIT0148450A
Kit filtrante rigenerabile prima installazione H16-H30 INOX Regenerable first installation filtering kit H16-H30 INOX	KIT0167743
Kit filtrante high performance prima installazione H16-H30 BIANCO High performance first installation filtering kit H16-H30 WHITE	KIT0181126
Kit filtrante rigenerabile prima installazione H16-H30 BIANCO Regenerable first installation filtering kit H16-H30 WHITE	KIT0181117

MODELLI MODELS	
LULLABY @ WH WOOD/A/120	PRF0167048
LULLABY @ WH WOOD/F/120 (*)	PRF0167049
LULLABY @ WOOD/A/120	PRF0167046
LULLABY @ WOOD/F/120 (*)	PRF0167047

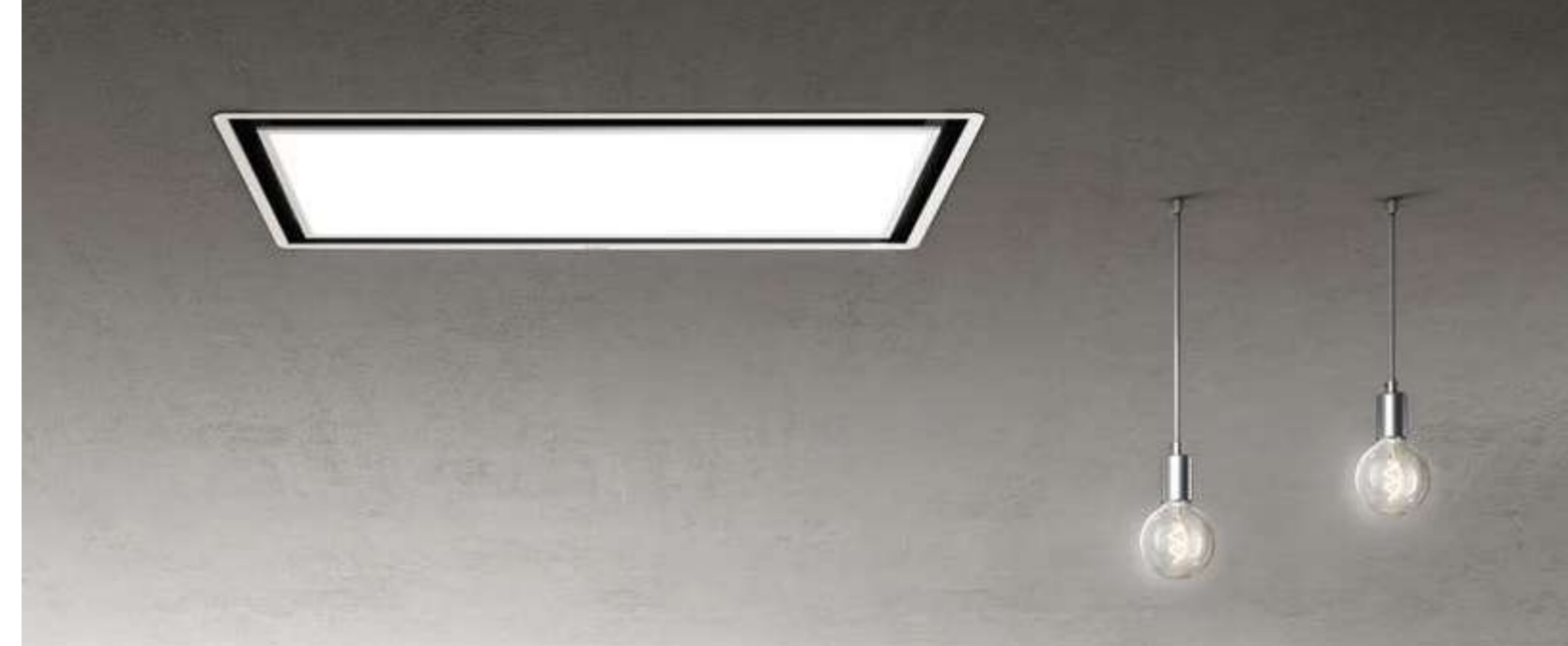

SKYDOME

DESIGN FABRIZIO CRISÀ
ELICA CONNECT

100x50 cm
Aspirante Duct-out
Cornice bianca White frame

 L'esclusiva soluzione H16 per controsoffitti con altezze limitate è stata progettata per mantenere elevate proprietà di aspirazione con bassi livelli sonori. Il pannello full LED può essere controllato da un interruttore a parete o radiocomando per regolare intensità e colore della luce. Possibilità di collegare al prodotto qualsiasi tipo di lampada disponibile sul mercato. Con Elica App, anche in assenza di connessione Wi-Fi, si può comandare la cappa attraverso lo smartphone o altri device attraverso una connessione locale diretta. The exclusive H16 solution for false ceilings with lower heights has been designed to maintain the excellent extraction properties with low noise levels. The full LED panel can be controlled by a wall-mounted switch or remote control to adjust the intensity and colour of the light. Possibility to connect the product to any commercially available light. Thanks to the Elica App, the hood can be operated via smartphone or other device, even without Wi-Fi connection, through a local direct connection.

H16 - NO MOTOR

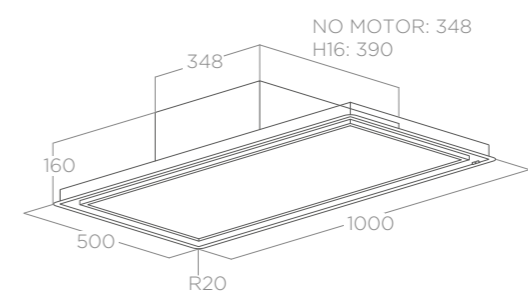





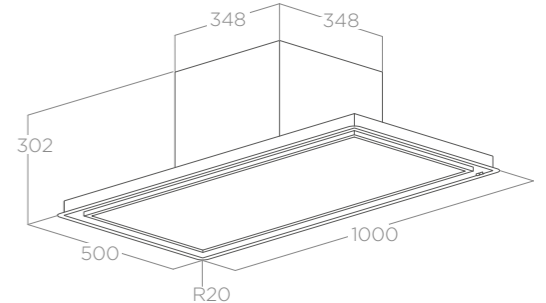





FALSE CEILING CUT 480X980

H30



FALSE CEILING CUT 480X980

-  TOTAL INTEGRATION
-  AIRMATIC
-  TUNE WHITE
-  DIM LIGHT
-  COMFORT SILENCE
-  CONNECTIVITY
-  SUPER EASY INSTALLATION
-  DELAY SWITCH OFF
-  MAINTENANCE ALARM
-  LONG LIFE FILTER ++
-  LONG LIFE FILTER
-  ENERGY CLASS (A+++D)

ACCESSORI ACCESSORIES

Kit filtrante a bordo H30 On board filtering kit H30	KIT0148449
Kit filtrante high performance prima installazione H16-H30 INOX High performance first installation filtering kit H16-H30 INOX	KIT0148450A
Kit filtrante rigenerabile prima installazione H16-H30 INOX Regenerable first installation filtering kit H16-H30 INOX	KIT0167743
Kit filtrante high performance prima installazione H16-H30 BIANCO High performance first installation filtering kit H16-H30 WHITE	KIT0181126
Kit filtrante rigenerabile prima installazione H16-H30 BIANCO Regenerable first installation filtering kit H16-H30 WHITE	KIT0181117
Radiocomando Design bianco White Design remote control	KIT0121468
Radiocomando Design nero Black Design remote control	KIT0121469
Motore remoto interno Remote internal motor	KIT0184296
Motore remoto esterno (muro) Remote external motor (wall)	KIT0184135
Motore remoto esterno (tetto) Remote external motor (roof)	KIT0147881
Motore remoto esterno (tetto inclinato) Remote external motor (inclined roof)	KIT0147882
Cavo Prolunga motore remoto Extension lead for remote motor	KIT0161392

ILLUMINAZIONE LIGHTING	
Tipo Type	Led Panel 28W
Intensità Intensity	1683 LUX
Temperatura Temperature	2400 K - 5000 K

PERFORMANCE PERFORMANCE		
Comandi Controls	Radiocomando 3V+2L 3S+2B Remote control H16 H30	
Portata intensiva Booster airflow	720 m³/h	770 m³/h
Livello sonoro min-max Noise level min-max	51 - 68 db(A)	40 - 53 db(A)
Assorbimento totale Total absorption	303 W	298 W

Filtro grassi alluminio incluso Grease aluminium filter included
Radiocomando incluso Remote control included

MODELLI MODELS	
SKYDOME H16 A/100	PRF0147735B
SKYDOME H30 A/100	PRF0146232B
SKYDOME NO MOTOR A/100	PRF0146230A

ILLUSION

DESIGN FABRIZIO CRISÀ



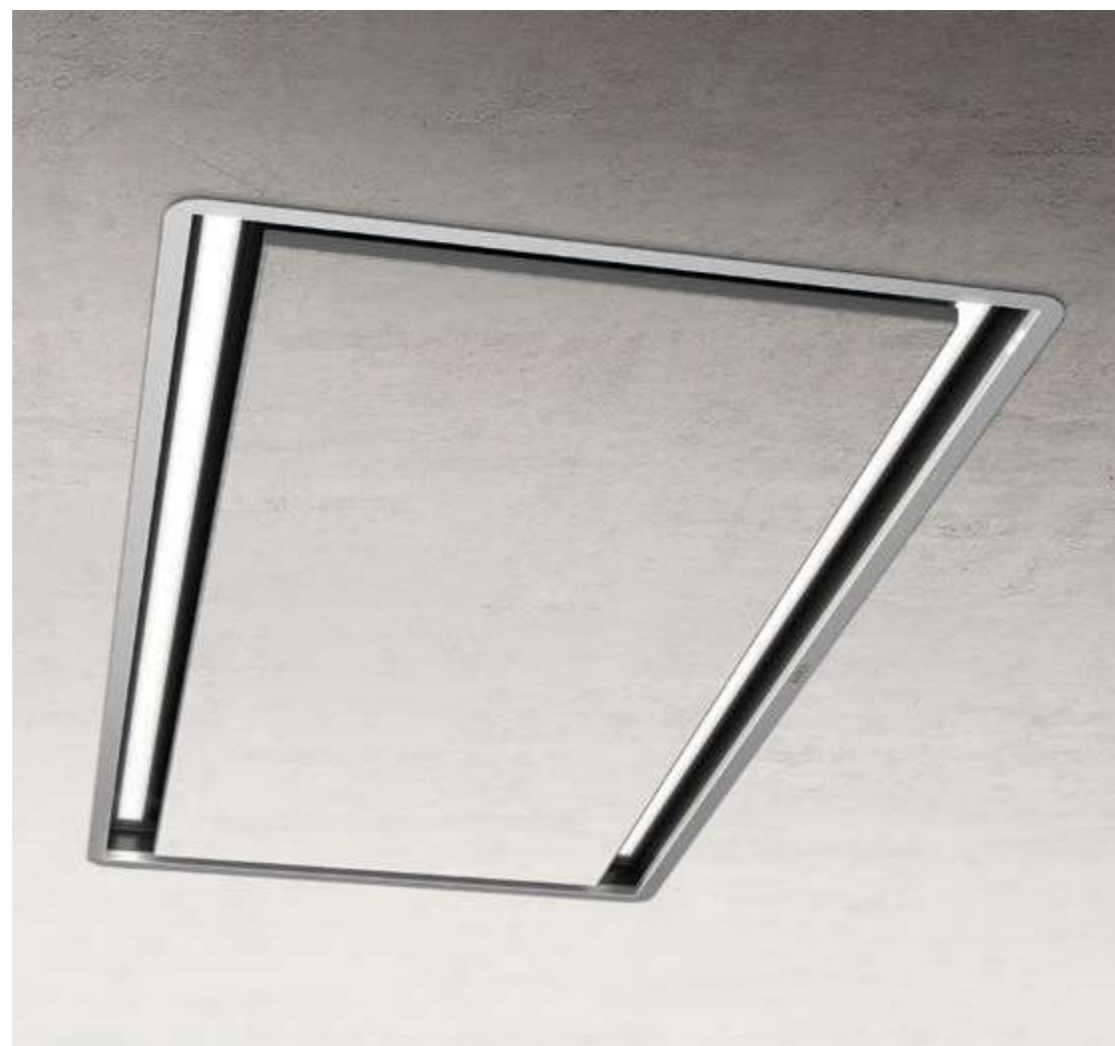

ILLUSION

DESIGN FABRIZIO CRISÀ
ELICA CONNECT

100x50 cm
Aspirante Duct-out
Bianco effetto soft touch + cornice bianca soft touch, rivestibile con cartongesso (non incluso) + cornice acciaio inox, nero effetto soft touch + cornice nera soft touch White soft touch effect + white soft touch frame, coverable with drywall (not included) + stainless steel frame, black soft touch effect + black soft touch frame

Modello unico e personalizzabile con cartongesso. Il cartongesso non è compreso nella confezione. L'esclusiva soluzione H16 per controsoffitti con altezze limitate è stata progettata per mantenere elevate proprietà di aspirazione con bassi livelli sonori. Possibilità di collegare al prodotto qualsiasi tipo di lampada disponibile sul mercato. Con Elica App, anche in assenza di connessione Wi-Fi, si può comandare la cappa attraverso lo smartphone o altri device attraverso una connessione locale diretta.

Unique and customisable model ready for cladding with gypsum panels. The gypsum panels are not included in the packaging. The exclusive H16 solution for false ceilings with lower heights has been designed to maintain the excellent extraction properties with low noise levels. Possibility to connect the product to any commercially available light. Thanks to the Elica App, the hood can be operated via smartphone or other device, even without Wi-Fi connection, through a local direct connection.

ILLUMINAZIONE LIGHTING		
Tipo Type	Strip Led 2x14 W	
Intensità Intensity	563 LUX	
Temperatura Temperature	2700 K - 5000 K	
PERFORMANCE PERFORMANCE		
Comandi Controls	Radiocomando 3V+2I 3S+2B Remote control	
	H16	H30
Portata intensiva Booster airflow	720 m³/h	770 m³/h
Livello sonoro min-max Noise level min-max	51 - 68 db(A)	40 - 53 db(A)
Assorbimento totale Total absorption	303 W	298 W

Filtro grassi alluminio incluso Grease aluminium filter included
Radiocomando incluso Remote control included

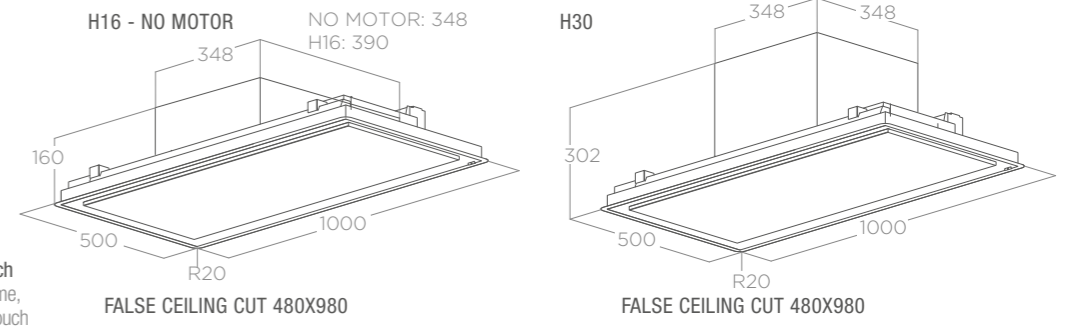

- TOTAL INTEGRATION
- AIRMATIC
- TUNE WHITE
- DIM LIGHT
- COMFORT SILENCE
- CONNECTIVITY
- SUPER EASY INSTALLATION
- DELAY SWITCH OFF
- MAINTENANCE ALARM
- LONG LIFE FILTER ++
- LONG LIFE FILTER
- Ø150
- ENERGY CLASS (A++-D)

ACCESSORI ACCESSORIES		
Kit filtrante a bordo H30 On board filtering kit H30		KIT0148449
Kit filtrante high performance prima installazione H16-H30 INOX High performance first installation filtering kit H16-H30 INOX		KIT0148450A
Kit filtrante rigenerabile prima installazione H16-H30 INOX Regenerable first installation filtering kit H16-H30 INOX		KIT0167743
Kit filtrante high performance prima installazione H16-H30 BIANCO High performance first installation filtering kit H16-H30 WHITE		KIT0181126
Kit filtrante rigenerabile prima installazione H16-H30 BIANCO Regenerable first installation filtering kit H16-H30 WHITE		KIT0181117
Kit filtrante high performance prima installazione H16-H30 NERO High performance first installation filtering kit H16-H30 BLACK		KIT0181124
Kit filtrante rigenerabile prima installazione H16-H30 NERO Regenerable first installation filtering kit H16-H30 BLACK		KIT0180993
Radiocomando Design bianco White Design remote control		KIT0121468
Radiocomando Design nero Black Design remote control		KIT0121469
Motore remoto interno Remote internal motor		KIT0184296
Motore remoto esterno (muro) Remote external motor (wall)		KIT0184135
Motore remoto esterno (tetto) Remote external motor (roof)		KIT0147881
Motore remoto esterno (tetto inclinato) Remote external motor (inclined roof)		KIT0147882
Cavo Prolunga motore remoto Extension lead for remote motor		KIT0161392

MODELLI MODELS		
ILLUSION H30 WH/A/100		PRF0146251B
ILLUSION H16 WH/A/100		PRF0147727B
ILLUSION NO MOTOR WH/A/100		PRF0146253A
ILLUSION H30 BL MAT/A/100		PRF0172646B
ILLUSION H16 BL MAT/A/100		PRF0172645B
ILLUSION NO MOTOR BL MAT/A/100		PRF0172647A
ILLUSION H30 PAINT/A/100		PRF0146250B
ILLUSION H16 PAINT/A/100		PRF0147726B
ILLUSION NO MOTOR PAINT/A/100		PRF0146252A

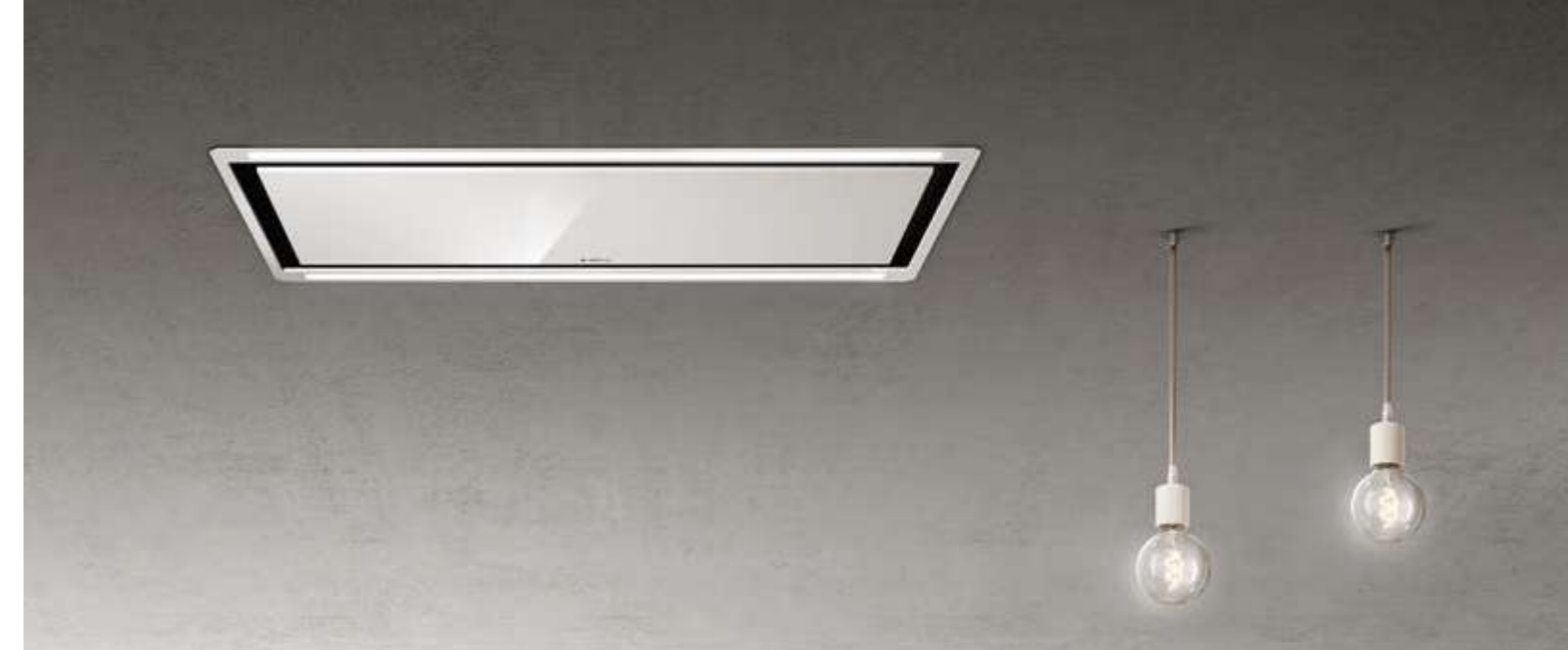

HILIGHT GLASS

DESIGN FABRIZIO CRISÀ

100x57 cm
Aspirante Duct-out
Vetro bianco + cornice bianca
White glass + white frame



L'esclusiva soluzione H16 per controsoffitti con altezze limitate è stata progettata per mantenere elevate proprietà di aspirazione con bassi livelli sonori. Le strip LED possono essere controllate da un interruttore a parete o radiocomando per regolare intensità e colore della luce. Possibilità di collegare al prodotto qualsiasi tipo di lampada disponibile sul mercato.

The exclusive H16 solution for false ceilings with lower heights has been designed to maintain the excellent extraction properties with low noise levels. The LED strips can be controlled by a wall-mounted switch or remote control to adjust the intensity and colour of the light. Possibility to connect the product to any commercially available light.

H16 - NO MOTOR

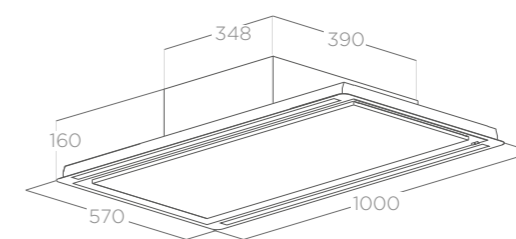

FALSE CEILING CUT 550X980

H30

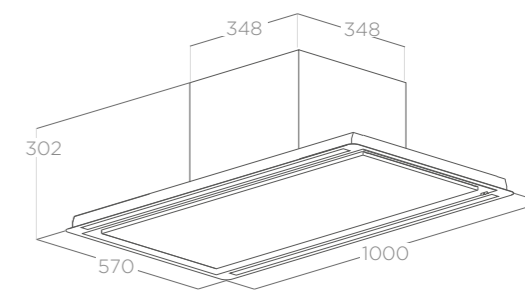

FALSE CEILING CUT 550X980



ILLUMINAZIONE LIGHTING		
Tipo Type	Strip Led 2x14 W	
Intensità Intensity	563 LUX	
Temperatura Temperature	2700 K - 5000 K	
PERFORMANCE PERFORMANCE		
	H16	H30
Comandi Controls	Radiocomando 3V + 2I 3S + 2B Remote control	Radiocomando 3V + 2I 3S + 2B Remote control
Portata intensiva Booster airflow	720 m³/h	770 m³/h
Livello sonoro min-max Noise level min-max	51 - 68 db(A)	40 - 53 db(A)
Assorbimento totale Total absorption	303 W	298 W
Filtro grassi alluminio incluso Grease aluminium filter included		
Radiocomando incluso Remote control included		

ACCESSORI ACCESSORIES

Kit filtrante a bordo H30 On board filtering kit H30	KIT0148449
Kit filtrante high performance prima installazione H16-H30 INOX High performance first installation filtering kit H16-H30 INOX	KIT0148450A
Kit filtrante rigenerabile prima installazione H16-H30 INOX Regenerable first installation filtering kit H16-H30 INOX	KIT0167743
Kit filtrante high performance prima installazione H16-H30 BIANCO High performance first installation filtering kit H16-H30 WHITE	KIT0181126
Kit filtrante rigenerabile prima installazione H16-H30 BIANCO Regenerable first installation filtering kit H16-H30 WHITE	KIT0181117
Radiocomando Design bianco White Design remote control	KIT0121468
Radiocomando Design nero Black Design remote control	KIT0121469
Motore remoto interno Remote internal motor	KIT0184296
Motore remoto esterno (muro) Remote external motor (wall)	KIT0184135
Motore remoto esterno (tetto) Remote external motor (roof)	KIT0147881
Motore remoto esterno (tetto inclinato) Remote external motor (inclined roof)	KIT0147882
Cavo Prolunga motore remoto Extension lead for remote motor	KIT0161392

MODELLI MODELS

HILIGHT GLASS H30 WH/A/100	PRF0146246A
HILIGHT GLASS H16 WH/A/100	PRF0167044A
HILIGHT GLASS NO MOTOR WH/A/100	PRF0146248



HIGHLIGHT-X

DESIGN FABRIZIO CRISÀ

100x57 cm
 Aspirante Duct-out
 Acciaio inox, bianco effetto soft touch, nero effetto soft touch
 Stainless steel, white soft touch effect, black soft touch effect

 L'esclusiva soluzione H16 per controsoffitti con altezze limitate è stata progettata per mantenere elevate proprietà di aspirazione con bassi livelli sonori. The exclusive H16 solution for false ceilings with lower heights has been designed to maintain the excellent extraction properties with low noise levels.

H16 - NO MOTOR

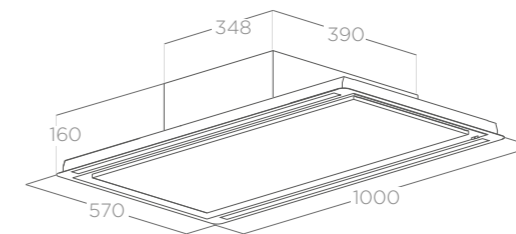

FALSE CEILING CUT 550X980

H30

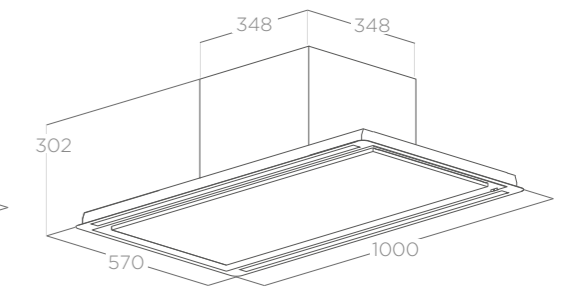

FALSE CEILING CUT 550X980



ACCESSORI ACCESSORIES

Kit filtrante a bordo H30 On board filtering kit H30	KIT0148449
Kit filtrante high performance prima installazione H16-H30 INOX High performance first installation filtering kit H16-H30 INOX	KIT0148450A
Kit filtrante rigenerabile prima installazione H16-H30 INOX Regenerable first installation filtering kit H16-H30 INOX	KIT0167743
Kit filtrante high performance prima installazione H16-H30 BIANCO High performance first installation filtering kit H16-H30 WHITE	KIT0181126
Kit filtrante rigenerabile prima installazione H16-H30 BIANCO Regenerable first installation filtering kit H16-H30 WHITE	KIT0181117
Kit filtrante high performance prima installazione H16-H30 NERO High performance first installation filtering kit H16-H30 BLACK	KIT0181124
Kit filtrante rigenerabile prima installazione H16-H30 NERO Regenerable first installation filtering kit H16-H30 BLACK	KIT0180993
Radiocomando Design bianco White Design remote control	KIT0121468
Radiocomando Design nero Black Design remote control	KIT0121469
Motore remoto interno Remote internal motor	KIT0184296
Motore remoto esterno (muro) Remote external motor (wall)	KIT0184135
Motore remoto esterno (tetto) Remote external motor (roof)	KIT0147881
Motore remoto esterno (tetto inclinato) Remote external motor (inclined roof)	KIT0147882
Cavo Prolunga motore remoto Extension lead for remote motor	KIT0161392

MODELLI MODELS

HIGHLIGHT-X H30 IX/A/100	PRF0163520A
HIGHLIGHT-X H16 IX/A/100	PRF0167045A
HIGHLIGHT-X NO MOTOR IX/A/100	PRF0163523
HIGHLIGHT-X H30 WH/A/100	PRF0173444A
HIGHLIGHT-X H16 WH/A/100	PRF0173442A
HIGHLIGHT-X H30 BL MAT/A/100	PRF0173445A
HIGHLIGHT-X H16 BL MAT/A/100	PRF0173443A

ILLUMINAZIONE LIGHTING

Tipo Type	Strip Led 2x7 W
Intensità Intensity	281 LUX
Temperatura Temperature	3500 K

PERFORMANCE PERFORMANCE

	H16	H30
Comandi Controls	Radiocomando 3V + 2I 3S + 2B Remote control	Radiocomando 3V + 2I 3S + 2B Remote control
Portata intensiva Booster airflow	720 m³/h	780 m³/h
Livello sonoro min-max Noise level min-max	51 - 68 db(A)	42 - 58 db(A)
Assorbimento totale Total absorption	189 W	184 W

Filtro grassi alluminio incluso Grease aluminium filter included
 Radiocomando incluso Remote control included





FILTRANTE



ASPIRANTE

CLOUD SEVEN

DESIGN FABRIZIO CRISÀ

90 cm
Aspirante/Filtrante Duct-out/Filtering
Acciaio inox + bianco Stainless steel + white



Modello Plug&Play, installabile facilmente, senza necessità di interventi su cartongesso o tubazioni aggiuntive (Cloud Seven Filtrante). Plug&Play model, easy-to-install, no need for building work on gypsum panels or additional pipes (Cloud Seven Filter).

ASPIRANTE

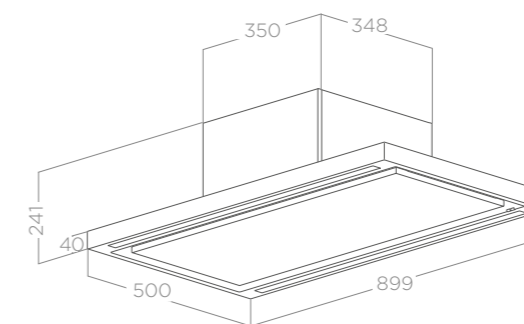

FILTRANTE

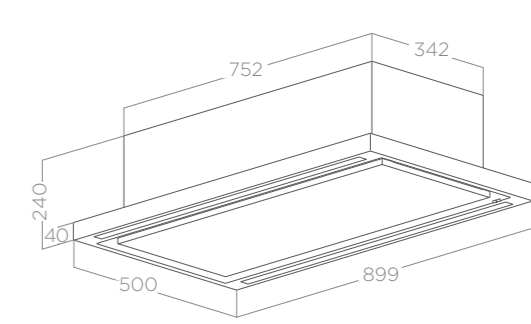

FALSE CEILING CUT 480X880



ILLUMINAZIONE LIGHTING		
Tipo Type	Strip Led 2x7 W	
Intensità Intensity	393 LUX	
Temperatura Temperature	3500 K	
PERFORMANCE PERFORMANCE		
	ASPIRANTE DUCT-OUT	FILTRANTE FILTERING
Comandi Controls	Radiocomando 3V + 2I 3S + 2B Remote control	Radiocomando 3V + I 3S + B Remote control
Portata intensiva Booster airflow	770 m³/h	570 m³/h
Livello sonoro min-max Noise level min-max	43 - 60 db(A)	52 - 68 db(A)
Assorbimento totale Total absorption	284 W	214 W
	Filtro grassi alluminio incluso Grease aluminium filter included	
	Filtro carbone rigenerabile incluso (*) Regenerable charcoal filter included (*)	
	Radiocomando incluso Remote control included	

ACCESSORI ACCESSORIES	
Filtro carbone rigenerabile Regenerable charcoal filter	CFC0140426
Filtro carbone rigenerabile per kit estetico Regenerable charcoal filter (filtering kit)	KIT0168748
Filtro carbone high performance per kit estetico Regenerable charcoal filter high performance (filtering kit)	KIT0168749
Kit filtrante high performance High performance filtering kit	KIT0148450A
Kit filtrante rigenerabile Regenerable filter kit	KIT0167743
Radiocomando Design bianco White Design remote control	KIT0121468
Radiocomando Design nero Black Design remote control	KIT0121469
Kit filtrante high performance prima installazione H16-H30 BIANCO High performance first installation filtering kit H16-H30 WHITE	KIT0181126
Kit filtrante rigenerabile prima installazione H16-H30 BIANCO Regenerable first installation filtering kit H16-H30 WHITE	KIT0181117
MODELLI MODELS	
CLOUD SEVEN IX/F/90 (*)	PRF0141953
CLOUD SEVEN IX/A/90	PRF0142094A
Modello non soggetto a certificazione energetica obbligatoria. (*) Model not subject to compulsory energy certification. (*)	

KIT FILTRI CARBONE CARBON FILTERS KIT

Alcuni dei modelli a soffitto sono progettati in versione aspirante, motivo per cui Elica ha realizzato dei kit completi che li convertono nella modalità di ricircolo aria.

KIT0148450A | KIT0181124 | KIT0181126 KIT FILTRANTE HIGH PERFORMANCE PRIMA INSTALLAZIONE

Contiene il filtro carbone rigenerabile high performance KIT0168749 e il pannello per l'uscita dell'aria

KIT0167743 | KIT0180993 | KIT0181117 KIT FITRANTE RIGENERABILE PRIMA INSTALLAZIONE

Contiene il filtro carbone rigenerabile KIT0168748 e il pannello per l'uscita dell'aria

KIT0148449 KIT FILTRANTE A BORDO H30

Kit di filtri da utilizzare solo per installazioni H30 - contiene 3 filtri da montare direttamente sul prodotto.

Some ceiling models have been designed in the duct out version: for this reason Elica has made complete kits available to convert them into filtering mode.

KIT0148450A | KIT0181124 | KIT0181126
HIGH PERFORMANCE FIRST INSTALLATION FILTERING KIT
It contains a regenerable high performance charcoal filter KIT0168749 and an air outlet panel

KIT0167743 | KIT0180993 | KIT0181117
REGENERABLE FIRST INSTALLATION FILTERING KIT
It contains a regenerable high performance charcoal filter KIT0168748 and an air outlet panel.

KIT0148449
ON BOARD FILTERING KIT H30
Filtering Kit only to be used for H30 installations - comes with 3 filters to be fitted directly on the product.

KIT PRIMA INSTALLAZIONE FILTRANTE FIRST INSTALLATION FILTERING KIT



KIT0148450A (Acciaio inox Stainless steel)
Kit filtrante high performance prima
installazione
High performance first installation filtering kit



KIT0181124 (Nero black)
Kit filtrante high performance prima
installazione
High performance first installation filtering kit



KIT0181126 (Bianco white)
Kit filtrante high performance prima
installazione
High performance first installation filtering kit



KIT0167743 (Acciaio inox Stainless steel)
Kit filtrante rigenerabile prima installazione
Regenerable first installation filtering kit



KIT0180993 (Nero black)
Kit filtrante rigenerabile prima installazione
Regenerable first installation filtering kit



KIT0181117 (Bianco white)
Kit filtrante rigenerabile prima installazione
Regenerable first installation filtering kit



KIT0148449
Kit filtrante a bordo H30
On board filtering kit H30

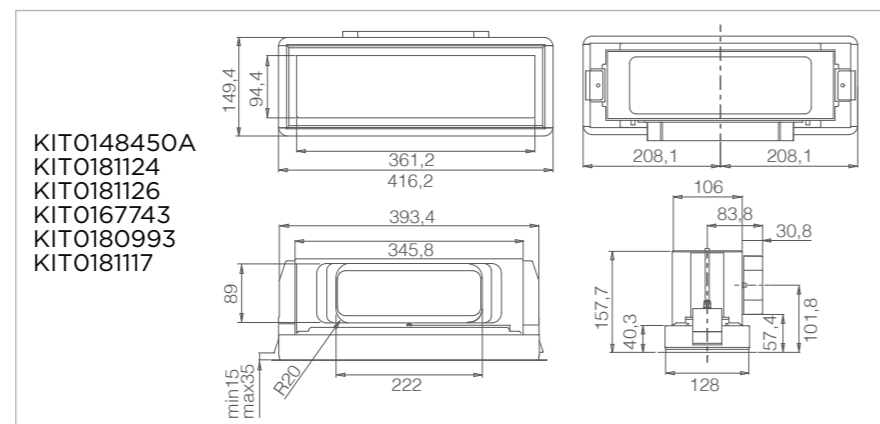

Da acquistare per convertire un modello aspirante in modalità filtrante.
Sold separately to convert a duct out model into filtering mode.

KIT FILTRI CARBONE CARBON FILTERS KIT

È disponibile, come ricambio, una serie completa di filtri antiodore, pensati per i modelli della gamma, tutti rigenerabili ed estremamente efficaci contro gli odori di cottura.

A complete series of odor filters has been specifically designed for models in this line, to be sold as spare parts, which are all regenerable and extremely efficient against cooking odors.

RICAMBI PER FILTRI ANTIODORE RIGENERABILI SPARE PARTS FOR REGENERABLE ODOR FILTERS



KIT0147861A
Filtro in ceramica anti-odori
Ceramic odour filter



CFC0140426
Filtro carbone rigenerabile
Regenerable charcoal filter



KIT0148449
Kit filtrante a bordo H30
Filtering kit H30



KIT0168748
Filtro carbone rigenerabile
Regenerating carbon filter



KIT0168749
Filtro carbone high performance
High Performance carbon filter

KIT FILTRI CARBONE CARBON FILTERS KIT

	EFFICIENZA DI FILTRAGGIO FILTERING EFFICIENCY	SKYDOME	HILIGHT GLASS	HILIGHT-X	ILLUSION	LULLABY Duct-out	LULLABY Filtering	CLOUD SEVEN Duct-out	CLOUD SEVEN Filtering
KIT0148450A KIT0181124 KIT0181126 Kit filtrante high performance prima installazione High performance first installation filtering kit	80%	X	X	X	X	X	---	X	---
KIT0167743 KIT0180993 KIT0181117 Kit filtrante rigenerabile prima installazione Regenerable first installation filtering kit	60%	X	X	X	X	X	---	X	---
KIT0148449 Kit filtrante a bordo H30 On board filtering kit H30	60%	---	---	---	---	X	---	---	---
KIT0168749 Filtro carbone high performance High Performance carbon filter	80%	X	X	X	X	X	---	X	---
CFC0140426 Filtro carbone rigenerabile Regenerable charcoal filter	60%	---	---	---	---	---	---	---	X
KIT0168748 Filtro carbone rigenerabile Regenerable charcoal filter	60%	X	X	X	X	X	---	X	---
KIT0147861A Filtro in ceramica anti-odori Ceramic odour filter	80%	---	---	---	---	---	X	---	---



Per garantire il corretto funzionamento dei modelli in versione filtrante, assicurarsi di posizionare l'uscita del ricircolo dell'aria almeno a:

- 150 cm dalla cappa
- 130 cm dal piano cottura
- 100 cm da muri o altre barriere architettoniche

In order to ensure the proper operation of filtering version models, make sure to position the air recirculation outlet at least at:

- 150 cm from the hood
- 130 cm from the hob
- 100 cm from the wall or other structural barriers

ACCESSORI TUBAZIONI CEILING CEILING PIPE FITTING ACCESSORIES



222x89x1000 mm
KIT0120991



222x89x500 mm
KIT0173527



Ø146 - 227x94 mm
KIT0121007



90° - 227x288x94 mm
KIT0121004



90° - 227x94 mm
KIT0121005



int 216x82 / est 290x160 mm
KIT0121009



227x94x80 mm
KIT0121001



Ø153 - 227x94 mm
KIT0121008



Ø150x500 mm
KIT0120996



Ø150x1000 mm
KIT0121000



Ø158x59 mm
KIT0121003



90° - Ø157
KIT0121006



Ø150x3000 mm
1052AD



Ø152x1000 mm
KIT0161455



227x94x560 mm
KIT0126810



Ø147 - 190x190 mm
KIT0121010

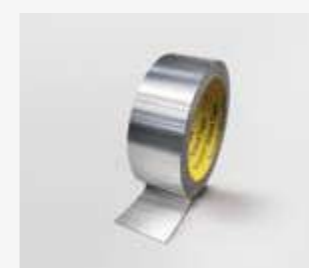

50 mm x 25 m
KIT0161453



Ø150x240 mm
KIT0161457

Per evitare la creazione di condensa e il ritorno della stessa verso la fonte di espulsione dell'aria, consigliamo di installare questo componente lungo la condotta di uscita, facendo attenzione di posizionarlo in orizzontale per assicurarne un corretto funzionamento.

Nel caso di gruppo motore remoto INLINE l'accessorio deve essere installato dopo il motore stesso.

To avoid the formation of condensate and the flowback towards the source of air output, we advise installing this component along the outlet pipe, taking care to position it horizontally to ensure correct operation.

The accessory must be installed on the motor if there is an INLINE remote motor unit.



SUSPENDED

La leggerezza della luce si accosta a potenti cuori aspiranti per dar vita a prodotti dall'alto valore estetico. Cappe che diventano scenografici lampadari in grado non solo di arredare l'ambiente, ma di garantire il migliore trattamento dell'aria, grazie a filtri di ultima generazione. Il sapiente utilizzo dei materiali permette di integrarsi in ogni ambiente e di caratterizzarlo: dal sofisticato e luminoso cristallo, perfetto per spazi eleganti e preziosi, al rame lucido o alla finitura ruggine, ideale per lo stile industrial. Punti luce inaspettati, in grado di sorprendere.

The elegance of the light is combined with powerful extraction units to produce attractive eye-catching hoods. Hoods that become spectacular ceiling lights that not only furnish the kitchen, but guarantee the best air treatment, thanks to the latest generation of filters. The skilful use of materials allows it to fit seamlessly into any environment and yet, make a statement: from the sophisticated and luminous glass, perfect for elegant and refined spaces, to the polished copper or rust finish, ideal for an industrial look. Unexpected points of light, for a wow factor.



INTERSTELLAR
DESIGN FABRIZIO CRISÀ



INTERSTELLAR

DESIGN FABRIZIO CRISÀ



Ø67 cm

Filtrante Recycling

Acciaio inox lucido + vetro, acciaio inox lucido + vetro nero

Shiny stainless steel + glass, shiny stainless steel + black glass

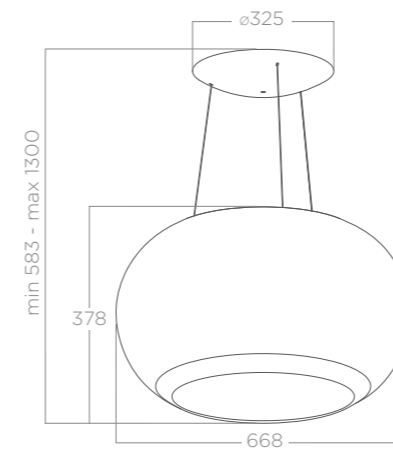
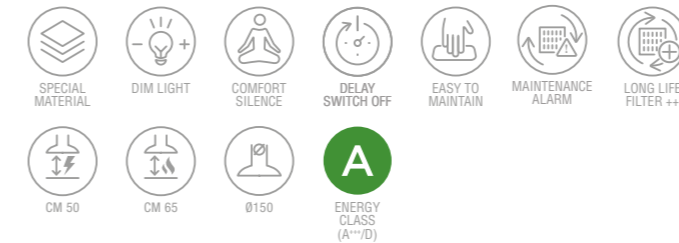

ILLUMINAZIONE LIGHTING

Tipo Type	Led 9 W
Intensità Intensity	261 LUX
Temperatura Temperature	3500 K

PERFORMANCE PERFORMANCE

Comandi Controls	Touch control capacitivo 3V+1 3S+B Capacitive touch control
Portata intensiva Booster airflow	384 m³/h
Livello sonoro min-max Noise level min-max	36 - 54 db(A)
Assorbimento totale Total absorption	134 W

Filtro grassi alluminio incluso Grease aluminium filter included
 Filtro carbone rigenerabile HP incluso Regenerable charcoal filter HP included
 Radiocomando incluso Remote control included

ACCESSORI ACCESSORIES

Filtro carbone rigenerabile HP Regenerable charcoal filter HP	CFC0140053
Filtro carbone rigenerabile Regenerable charcoal filter	CFC0140090
Radiocomando Design bianco White Design remote control	KIT0121468
Radiocomando Design nero Black Design remote control	KIT0121469
Kit prolunga cavi (5m) Extension cable kit (5m)	KIT0112772

MODELLI MODELS

INTERSTELLAR IX/F/65	PRF0151808
INTERSTELLAR BL/F/65	PRF0151809





SEASHELL

DESIGN FABRIZIO CRISÀ

Ø80 cm

Filtrante Filtering

Bianco perla, bianco opaco, nero opaco, acciaio inox lucido
Pearl, matt white, matt black, shiny stainless steel

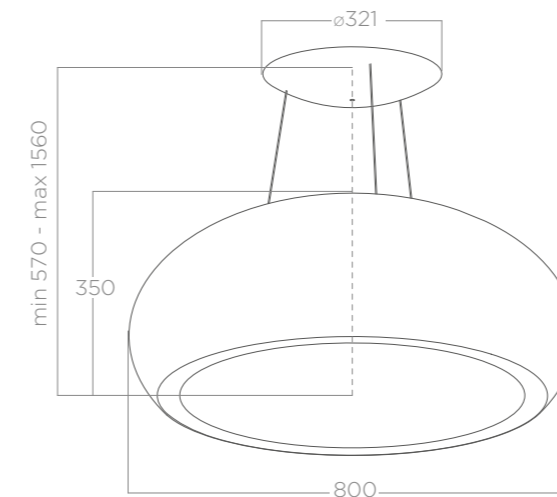

ILLUMINAZIONE LIGHTING

Tipo Type	Neon 4x24 W
Intensità Intensity	1386 LUX
Temperatura Temperature	6500 K

PERFORMANCE PERFORMANCE

Comandi Controls	Radiocomando 3V+1 3S+B Remote control
Portata intensiva Booster airflow	400 m ³ /h
Livello sonoro min-max Noise level min-max	55 - 67 db(A)
Assorbimento totale Total absorption	350 W

Filtro grassi alluminio incluso Grease aluminium filter included
Filtro carbone rigenerabile incluso Regenerable charcoal filter included
Radiocomando incluso Remote control included

ACCESSORI ACCESSORIES

Filtro carbone rigenerabile Regenerable charcoal filter	CFC0141725A
Radiocomando Design bianco White Design remote control	KIT0121468
Radiocomando Design nero Black Design remote control	KIT0121469
Kit prolunga cavi (2,5m) Extension cable kit (2,5m)	KIT0067590

MODELLI MODELS

SEASHELL IX/F/80	PRF0098394
SEASHELL BL/F/80	PRF0098393
SEASHELL WH/F/80	PRF0024262A
SEASHELL WH MAT/F/80	PRF0098392

Modello non soggetto a certificazione energetica obbligatoria.
Model not subject to compulsory energy certification.



SHINING
DESIGN FABRIZIO CRISÀ



SHINING CAST IRON



SHINING CAST IRON



SHINING

DESIGN FABRIZIO CRISÀ

Ø 50 cm

Filtrante Recycling

Metallo effetto: peltrox, ruggine, ghisa

Metal: peltrox, rust, cast iron effect

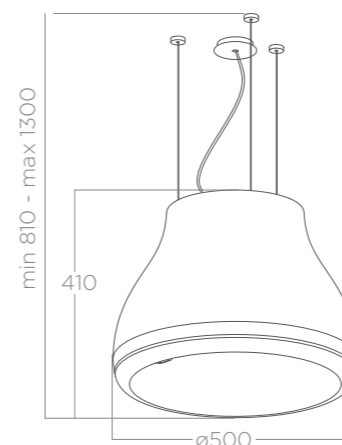
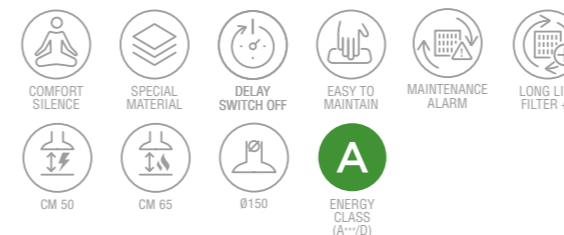

Installabile anche a muro ordinando il kit installazione accessorio.
Possibility for wall mounting by ordering the ancillary installation.

ILLUMINAZIONE LIGHTING

Tipo Type	Led 9 W
Intensità Intensity	685 LUX
Temperatura Temperature	3500 K

PERFORMANCE PERFORMANCE

Comandi Controls	Touch control capacitivo 3V+I 3S+B Capacitive touch control
Portata intensiva Booster airflow	460 m³/h
Livello sonoro min-max Noise level min-max	46 - 53 db(A)
Assorbimento totale Total absorption	179 W

Filtro grassi alluminio incluso Grease aluminium filter included
Filtro carbone rigenerabile HP incluso Regenerable charcoal filter HP included
Radiocomando incluso Remote control included

ACCESSORI ACCESSORIES

Filtro carbone rigenerabile HP Regenerable charcoal filter HP	CFC0140053
Filtro carbone rigenerabile Regenerable charcoal filter	CFC0140090
Radiocomando Design bianco White Design remote control	KIT0121468
Radiocomando Design nero Black Design remote control	KIT0121469
Kit installazione a parete cromato Chrome wall installation kit	KIT0146156
Kit installazione a parete nero Black wall installation kit	KIT0146155
Kit prolunga cavi (5m) Extension cable kit (5m)	KIT0112772

MODELLI MODELS

SHINING CAST IRON/F/50	PRF0120590A
SHINING PELTROX/F/50	PRF0120497A
SHINING RUST/F/50	PRF0120528A



SHINING PELTROX



SHINING RUST



ÈDITH
DESIGN FABRIZIO CRISÀ



ÉDITH ROCK



ÉDITH CLASSIC



ÉDITH HEAVY METAL



ÉDITH

DESIGN FABRIZIO CRISÀ



Ø 50 cm

Filtrante Recycling

Nero effetto soft touch, bianco effetto soft touch, acciaio inox lucido
Black soft touch effect, white soft touch effect, shiny stainless steel

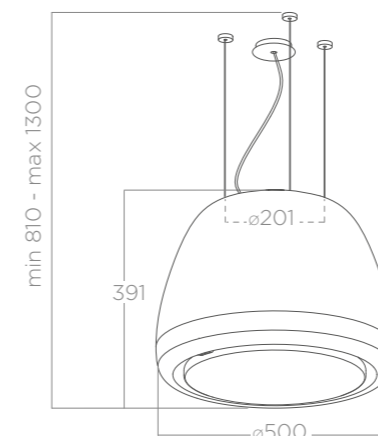
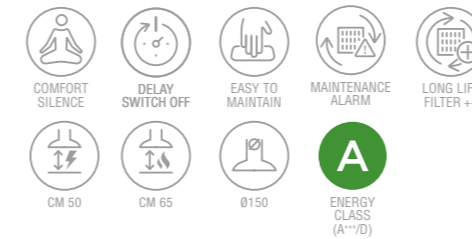

Installabile anche a muro ordinando il kit installazione accessorio.
Possibility for wall mounting by ordering the ancillary installation.

ILLUMINAZIONE LIGHTING

Tipo Type	Led 9 W
Intensità Intensity	685 LUX
Temperatura Temperature	3500 K

PERFORMANCE PERFORMANCE

Comandi Controls	Touch control capacitivo 3V+I 3S+B Capacitive touch control
Portata intensiva Booster airflow	460 m ³ /h
Livello sonoro min-max Noise level min-max	46 - 53 db(A)
Assorbimento totale Total absorption	179 W

Filtro grassi alluminio incluso Grease aluminium filter included
Filtro carbone rigenerabile HP incluso Regenerable charcoal filter HP included
Radiocomando incluso Remote control included

ACCESSORI ACCESSORIES

Filtro carbone rigenerabile HP Regenerable charcoal filter HP	CFC0140053
Filtro carbone rigenerabile Regenerable charcoal filter	CFC0140090
Radiocomando Design bianco White Design remote control	KIT0121468
Radiocomando Design nero Black Design remote control	KIT0121469
Kit installazione a parete cromato Chrome wall installation kit	KIT0146156
Kit installazione a parete nero Black wall installation kit	KIT0146155
Kit prolunga cavi (5m) Extension cable kit (5m)	KIT0112772

MODELLI MODELS

EDITH CLASSIC/F/50	PRF0098360
EDITH HEAVYMETAL/F/50	PRF0098364
EDITH ROCK/F/50	PRF0098361



WAVE UX
DESIGN FABRIZIO CRISÀ



WAVE UX

DESIGN FABRIZIO CRISÀ

Ø50 cm

Filtrante Recycling

Acciaio inox, nero effetto soft touch

Stainless steel, black soft touch effect

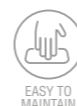

ILLUMINAZIONE LIGHTING

Tipo Type	Led 3X2,5 W + Led 4X3 W
Intensità Intensity	211 LUX
Temperatura Temperature	4000 K

PERFORMANCE PERFORMANCE

Comandi Controls	Touch control capacitivo 3V+I 3S+B Capacitive touch control
Portata intensiva Booster airflow	610 m ³ /h
Livello sonoro min-max Noise level min-max	46 - 62 db(A)
Assorbimento totale Total absorption	219,5 W

Filtro grassi alluminio incluso Grease aluminium filter included
Filtro carbone rigenerabile incluso Regenerable charcoal filter included

ACCESSORI ACCESSORIES

Filtro carbone rigenerabile Regenerable charcoal filter	CFC0140088
Kit prolunga cavi (2,5m) Extension cable kit (2,5m)	KIT01889
Kit prolunga cavi (5m) Extension cable kit (5m)	KIT01921
Kit installazione a parete acciaio inox Stainless steel wall installation kit	KIT0175805
Kit installazione a parete nero Black wall installation kit	KIT0175806

MODELLI MODELS

WAVE UX BL MAT/F/51	PRF0171193
WAVE UX IX/F/51	PRF0171194

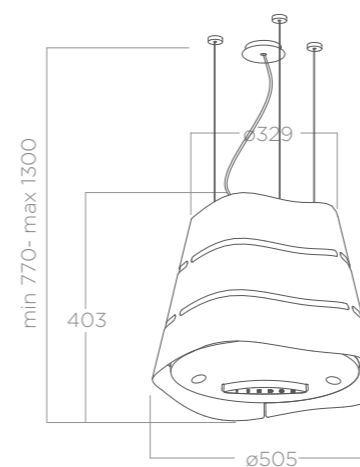

Installabile anche a muro ordinando il kit installazione accessorio.
Possibility for wall mounting by ordering the ancillary installation.





EASY UX

DESIGN FABRIZIO CRISÀ



Ø50 cm

Filtrante Recycling

Acciaio inox, nero effetto soft touch, bianco effetto soft touch
Stainless steel, black soft touch effect, white soft touch effect

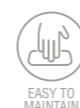

A

ILLUMINAZIONE LIGHTING

Tipo Type	Led 3X2,5 W
Intensità Intensity	211 LUX
Temperatura Temperature	4000 K

PERFORMANCE PERFORMANCE

Comandi Controls	Touch control capacitivo 3V+I 3S+B Capacitive touch control
Portata intensiva Booster airflow	610 m ³ /h
Livello sonoro min-max Noise level min-max	46 - 62 db(A)
Assorbimento totale Total absorption	207,5 W

Filtro grassi alluminio incluso Grease aluminium filter included
Filtro carbone rigenerabile incluso Regenerable charcoal filter included

ACCESSORI ACCESSORIES

Filtro carbone rigenerabile Regenerable charcoal filter	CFC0140088
Kit prolunga cavi (2,5m) Extension cable kit (2,5m)	KIT01889
Kit prolunga cavi (5m) Extension cable kit (5m)	KIT01921
Kit installazione a parete acciaio inox Stainless steel wall installation kit	KIT0175805
Kit installazione a parete nero Black wall installation kit	KIT0175806

MODELLI MODELS

EASY UX BL MAT/F/50	PRF0120352A
EASY UX IX/F/50	PRF0120354A
EASY UX WH/F/50	PRF0119940A

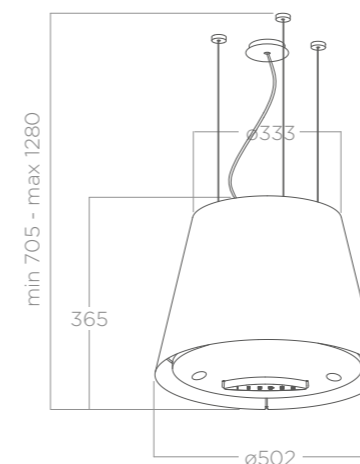

Installabile anche a muro ordinando il kit installazione accessorio.
Possibility for wall mounting by ordering the ancillary installation.



PIX
DESIGN FABRIZIO CRISÀ



PIX CONCRETE



PIX WHITE



PIX

DESIGN FABRIZIO CRISÀ

42x42 cm

Filtrante Recycling

Bianco effetto soft touch, nero effetto soft touch, finitura cemento, finitura denim
White soft touch effect, black soft touch effect, concrete finish, denim finish



ILLUMINAZIONE LIGHTING

Tipo Type	Strip Led 1x7 W
Intensità Intensity	365 LUX
Temperatura Temperature	3500 K

PERFORMANCE PERFORMANCE

Comandi Controls	Touch control capacitivo 3V+I 3S+B Capacitive touch control
Portata intensiva Booster airflow	610 m ³ /h
Livello sonoro min-max Noise level min-max	44 - 60 db(A)
Assorbimento totale Total absorption	207 W

Filtro grassi alluminio incluso Grease aluminium filter included
Filtro carbone rigenerabile incluso Regenerable charcoal filter included

ACCESSORI ACCESSORIES

Filtro carbone rigenerabile Regenerable charcoal filter	KIT0147175
Kit installazione a parete acciaio inox Stainless steel wall installation kit	KIT0146153
Kit prolunga cavi (2,5m) Extension cable kit (2,5m)	KIT0147941
Kit prolunga cavi (5m) Extension cable kit (5m)	KIT0147942

MODELLI MODELS

PIX BL/F/42	PRF0146220
PIX WH/F/42	PRF0145561
PIX JEANS/F/42	PRF0146221
PIX CONCRETE/F/42	PRF0146222

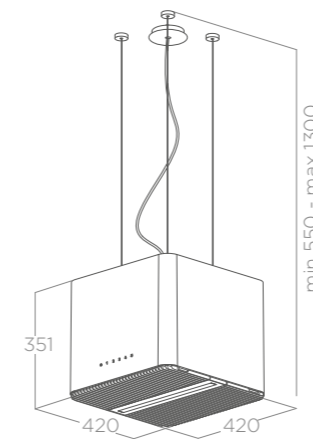

Installabile anche a muro ordinando il kit installazione accessorio.
Possibility for wall mounting by ordering the ancillary installation.

IKONA LIGHT

DESIGN FABRIZIO CRISÀ





IKONA LIGHT IX



IKONA LIGHT WH



IKONA LIGHT BL MAT



Suspended

IKONA LIGHT

DESIGN FABRIZIO CRISÀ

60 cm

Filtrante Filtering

Acciaio inox, nero effetto soft touch, bianco effetto soft touch
Stainless steel, black soft touch effect, white soft touch effect



EASY TO MAINTAIN



MAINTENANCE ALARM



LONG LIFE FILTER



CM 50



CM 60



Ø150



ENERGY CLASS (A-D)

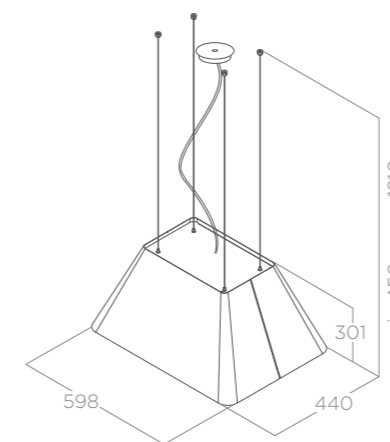

Installabile anche a muro ordinando il kit installazione accessorio.
Possibility for wall mounting by ordering the ancillary installation.

ILLUMINAZIONE LIGHTING

Tipo Type	Strip Led 1x7 W
Intensità Intensity	365 LUX
Temperatura Temperature	3500 K

PERFORMANCE PERFORMANCE

Comandi Controls	Touch control capacitivo 3V+I 3S+B Capacitive touch control
Portata intensiva Booster airflow	605 m ³ /h
Livello sonoro min-max Noise level min-max	47 - 62 db(A)
Assorbimento totale Total absorption	207 W

Filtro grassi alluminio incluso Grease aluminium filter included
Filtro carbone incluso Charcoal filter included

ACCESSORI ACCESSORIES

Filtro carbone Charcoal filter	CFC0140343
Filtro carbone rigenerabile Regenerable charcoal filter	CFC0162221
Kit installazione a parete acciaio inox Stainless steel wall installation kit	KIT0175807
Kit installazione a parete nero Black wall installation kit	KIT0175808
Kit prolunga cavi (2,5m) Extension cable kit (2,5m)	KIT0147941
Kit prolunga cavi (5m) Extension cable kit (5m)	KIT0147942

MODELLI MODELS

IKONA LIGHT IX/F/60	PRF0165071
IKONA LIGHT BL MAT/F/60	PRF0165082
IKONA LIGHT WH/F/60	PRF0165083



JUNO WH



JUNO IX



JUNO BL



JUNO CAST IRON



JUNO ZINC

JUNO

ELICA DESIGN CENTER



Ø 50 cm
Filtrante Recycling
Acciaio inox, bianco, nero
Stainless steel, white, black

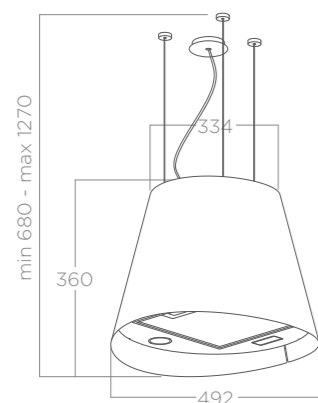
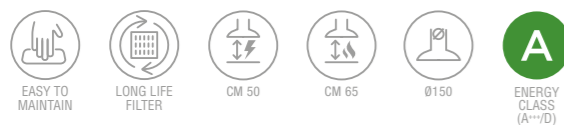

Installabile anche a muro ordinando il kit installazione accessorio.
Possibility for wall mounting by ordering the ancillary installation.

ILLUMINAZIONE LIGHTING

Tipo Type Led 2x2,5 W
Intensità Intensity 381 LUX
Temperatura Temperature 3500 K

PERFORMANCE PERFORMANCE

Comandi Controls Pulsantiera soft light 3V
3S Soft light push button
Portata massima Max airflow 620 m³/h
Livello sonoro min-max Noise level min-max 45 - 67 db(A)
Assorbimento totale Total absorption 205 W

Filtro grassi alluminio incluso Grease aluminium filter included
Filtro carbone rigenerabile incluso Regenerable charcoal filter included

ACCESSORI ACCESSORIES

Filtro carbone rigenerabile Regenerable charcoal filter CFC0140088
Kit installazione a parete acciaio inox Stainless steel wall installation kit KIT0175805
Kit installazione a parete nero Black wall installation kit KIT0175806
Kit prolunga cavi (2,5m) Extension cable kit (2,5m) KIT01889
Kit prolunga cavi (5m) Extension cable kit (5m) KIT01921

MODELLI MODELS

JUNO IX/F/50 PRF0089651D
JUNO BL/F/50 PRF0071970D
JUNO WH/F/50 PRF0071972D

JUNO URBAN

ELICA DESIGN CENTER



Ø 50 cm
Filtrante Recycling
Metallo effetto ghisa, metallo effetto zincato
Cast iron effect metal, zinc coating effect metal

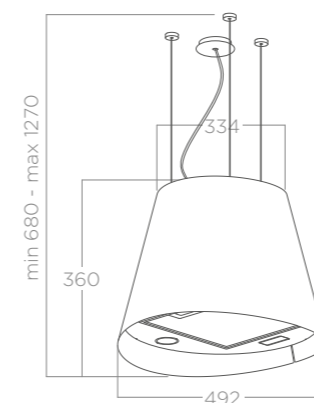

Installabile anche a muro ordinando il kit installazione accessorio.
Possibility for wall mounting by ordering the ancillary installation.

ILLUMINAZIONE LIGHTING

Tipo Type Led 2x2,5 W
Intensità Intensity 381 LUX
Temperatura Temperature 3500 K

PERFORMANCE PERFORMANCE

Comandi Controls Pulsantiera soft light 3V
3S Soft light push button
Portata massima Max airflow 620 m³/h
Livello sonoro min-max Noise level min-max 45 - 67 db(A)
Assorbimento totale Total absorption 205 W

Filtro grassi alluminio incluso Grease aluminium filter included
Filtro carbone rigenerabile incluso Regenerable charcoal filter included

ACCESSORI ACCESSORIES

Filtro carbone rigenerabile Regenerable charcoal filter CFC0140088
Kit installazione a parete acciaio inox Stainless steel wall installation kit KIT0175805
Kit installazione a parete nero Black wall installation kit KIT0175806
Kit prolunga cavi (2,5m) Extension cable kit (2,5m) KIT01889
Kit prolunga cavi (5m) Extension cable kit (5m) KIT01921

MODELLI MODELS

JUNO URBAN CAST IRON/F/50 PRF0147728B
JUNO URBAN ZINC/F/50 PRF0147730B

DOWNDRAFT

La discrezione di linee pulite e finiture che scompaiono nel top, integrandosi perfettamente con la superficie in cui sono progettate, caratterizza le cappe downdraft di Elica. Un meccanismo up&down che assicura elevate performance di aspirazione quando la cappa viene azionata, per poi scomparire nel top quando viene spenta, regalando un design lineare e fluido alla cucina.

Grazie al motore remoto, l'armonia dell'ambiente non viene disturbata dal rumore del potente cuore aspirante. Per il massimo comfort.

The discretion of clean lines and finishes that disappear into the countertop, lying flush to the surface on which they are designed, is the hallmark of Elica's downdraft hoods. An up&down mechanism ensures high extraction performance when the hood is switched on, which then disappears into the countertop when turned off, ensuring a linear and streamlined kitchen design.

The remote motor means the harmony in the kitchen remains undisturbed by the noise of the powerful extraction unit. For maximum comfort.



GETUP

DESIGN FABRIZIO CRISÀ





GETUP NAKED



GETUP IX



GETUP CAST IRON



GETUP NAKED



GETUP

DESIGN FABRIZIO CRISÀ

ELICA CONNECT

90 cm

Aspirante Duct-out

Acciaio inox, nero effetto soft touch + vetro nero, effetto ghisa, effetto ghisa + rivestibile

Stainless steel, black soft touch effect + black glass, cast iron effect, cast iron effect + coverable

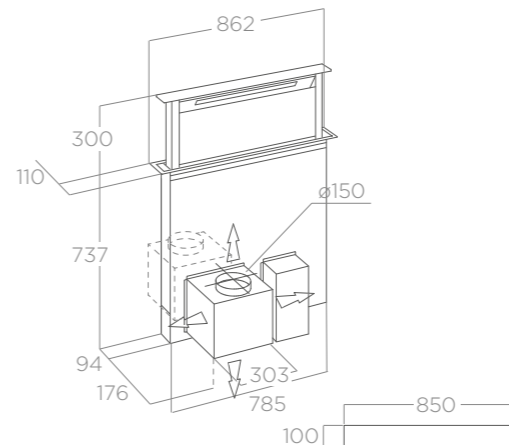

CUT FOR INSTALLATION

Con Getup la libertà e il comfort sono massimi grazie all'interfaccia utente sempre visibile frontalmente e alla comodità dell'assistente vocale o del telecomando tramite APP nella gestione del flusso d'aria, dell'intensità della luce e della manutenzione del prodotto.

Total freedom and comfort with Getup, thanks to the user interface displayed on the front and the handy voice assistant or remote control via the app, to manage the air flow, light intensity and product maintenance.

ILLUMINAZIONE LIGHTING

Tipo Type	STRIP LED 1x7W
Intensità Intensity	253 LUX
Temperatura Temperature	3500 K

PERFORMANCE PERFORMANCE

Comandi Controls	Touch control infrarossi 3V+2I 3S+2B Infrared touch control
Portata intensiva Booster airflow	730 m ³ /h
Livello sonoro min-max Noise level min-max	43 - 63 db(A)
Assorbimento totale Total absorption	275 W

Filtro grassi alluminio incluso Grease aluminium filter included

ACCESSORI ACCESSORIES

Kit filtro carbone rigenerabile HP Regenerable charcoal filter HP	KIT0166432
Kit filtro carbone rigenerabile Regenerable carbon filter kit	KIT0166444
Kit trasformazione motore satellite Remote motor transformation kit	KIT0166435
Profilo estetico cromato Chrome-plated trim profile	KIT0187322

MODELLI MODELS

GETUP IX/A/90	PRF0161680
GETUP BL MAT/A/90	PRF0162784
GETUP CAST IRON/A/90	PRF0162866
GETUP NAKED/A/90	PRF0162869

Stile essenziale e minimale Understated, minimal style

Il nuovo modello Getup arricchisce il classico downdraft di stile e soluzioni tecnologiche all'avanguardia, in grado di assicurare il massimo comfort in cucina.

Nasce dall'esigenza di chi predilige un ambiente minimale ma allo stesso tempo è attento alla rimozione efficace dei vapori e degli odori in casa, Getup si integra perfettamente nell'arredo della cucina e rivela la sua efficacia solo quando necessario.

The new Getup model enhances the classic downdraft style and cutting-edge technological solutions which ensure the utmost comfort in the kitchen.

It stems from the demand of those aiming for a minimal setting, but one that is also focused on efficiently removing vapours and odours in the home.



Massima libertà di installazione Total installation freedom

Getup si inserisce con discrezione in ogni tipo di cucina, lasciando la massima libertà di installazione e occupando uno spazio minimo all'interno del mobile grazie alle dimensioni e alla posizione del gruppo aspirante che consente cassette più profonde.

Il motore, incluso nella scatola, può essere montato a bordo e su entrambi i lati del prodotto con possibilità di ruotare l'uscita nelle quattro direzioni per soddisfare qualsiasi esigenza di installazione. La stessa unità di aspirazione può essere anche remotizzata (fino a 3 mt), liberando l'ingombro all'interno del mobile e mantenendo performance efficaci alla massima silenziosità.

Getup blends discretely into any type of kitchen, leaving total freedom for installation and taking up a minimum amount of space inside the unit, thanks to its size and the position of the extraction unit which allows for deeper drawers.

The motor, included in the box, can be assembled on-board or on both sides of the product, with the option of turning the outlet in four directions to meet any installation requirement. The same extraction unit can also be installed remotely (up to 3 metres), freeing up space inside the unit whilst maintaining efficient performance and low noise levels.



Soluzioni originali Original solutions

I materiali rappresentano da sempre per Elica uno degli elementi fondamentali del processo di innovazione, consentendo la creazione di soluzioni distintive, in linea con le tendenze del settore dell'arredamento.

La finitura nera, in Getup, viene interpretata con una combinazione di vetro nero e particolari in vernice soft touch mentre la classica soluzione in acciaio rivela la sua eleganza senza tempo. La versione effetto ghisa rappresenta una vera novità: sottolineata da un profilo in titanio la finitura discretamente brillante si sposa perfettamente con i nuovi stili di cucina e con gli elementi estetici dei piani a gas. Il modello "naked" consente di rivestire il pannello superiore con qualsiasi texture, anche la stessa del piano di lavoro, rendendo Getup un prodotto unico e personalizzabile.

Materials have always been one of the fundamental elements for Elica in the innovation process, resulting in statement solutions, in line with trends in the furnishing sector. In Getup, the black finish is interpreted with a combination of black glass and details in soft touch paint while the classic solution in steel showcases its timeless elegance.

The cast-iron effect is a brand-new addition: highlighted by a titanium trim, the subtly bright finish blends in perfectly with new kitchen styles and the aesthetic elements of the gas hobs. The "naked" model allows you to cover the upper panel with any texture, even the same one as the worktop, making Getup a one-of-a-kind, customisable product.

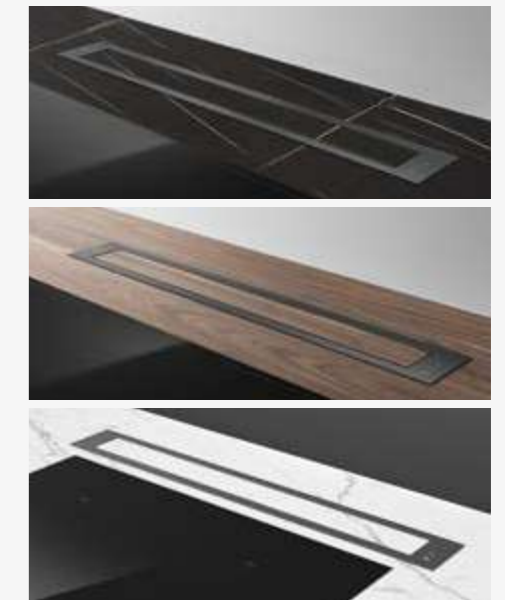

Interazione intelligente e connessione Wi-fi Smart interaction and Wi-fi connection

Interagire con Getup è sorprendentemente naturale. L'innovativa interfaccia utente è sempre davanti ai tuoi occhi ed ogni funzione può essere selezionata con un tocco sulla parte laterale del prodotto, evitando di passare sopra pentole e fuochi, in completa sicurezza.

Getup è dotata di modulo Wi-fi: aspirazione e luci possono essere controllate anche tramite la App dedicata e gli smart speaker più diffusi. Utilizzando la App Elica Connection è possibile avere utili feedback sulla manutenzione dei filtri e sulle buone abitudini di utilizzo della cappa.

ELICA CONNECT



Interacting with Getup is surprisingly natural. The innovative user interface is always on view and all the functions can be selected with a touch on the side part of the product, so you don't have to reach over pans or the hot stove, ensuring complete safety.

Getup comes with Wi-fi: extraction and lights can be controlled via the dedicated App and widely-used smart speakers. Using the Elica Connection App, it is possible to receive useful feedback on filter maintenance and the best ways to use the hood.

PANDORA BL



PANDORA IX



PANDORA

ELICA DESIGN CENTER

90 cm

Filtrante (motore interno) Filtering (internal motor)

Aspirante (motore esterno) Duct-out (external motor)

Acciaio inox + vetro nero, nero + vetro nero

Stainless steel + black glass, black + black glass

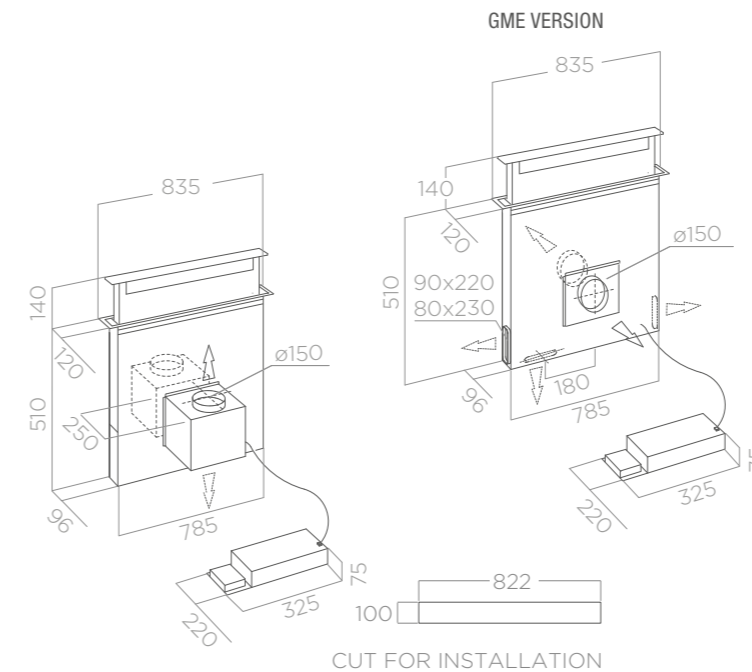
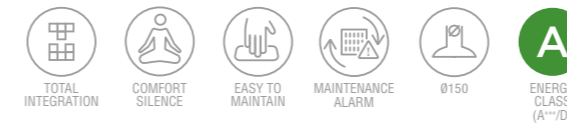

PERFORMANCE PERFORMANCE

Comandi Controls	Pulsantiera elettronica 3V+I 3S+B Electronic push button
Portata intensiva Booster airflow	669 m³/h
Livello sonoro min-max Noise level min-max	45 - 59 db(A)
Assorbimento totale Total absorption	275 W

Filtro grassi alluminio incluso Grease aluminium filter included
Filtro carbone incluso (*) Charcoal filter included (*)

ACCESSORI ACCESSORIES

Filtro carbone Charcoal filter	CFC0142324
Motore remoto esterno GME22A (muro) Remote external motor GME22A (wall)	PRF0179706
Motore remoto interno GME88 Remote external interno GME88	PRF0046491A

MODELLI MODELS

PANDORA IX/F/90 (*)	PRF0120980
PANDORA GME IX/A/90 (**)	PRF0120982
PANDORA BL/F/90 (*)	PRF0120979
PANDORA GME BL/A/90 (**)	PRF0120981

(*) Motore a bordo fornito
On-board motor supplied

() Motore remoto non fornito**
Remote motor not supplied

TUBAZIONI ACCESSORIE PER VERSIONE ASPIRANTE ACCESSORY PIPE FITTINGS FOR DUCT-OUT VERSION

TUBAZIONI ACCESSORIE PER VERSIONE FILTRANTE ACCESSORY PIPE FITTINGS FOR FILTERING VERSION



222x89x1000 mm
KIT0120991



222x89x500 mm
KIT0173527



Ø150x500 mm
KIT0120996



Ø150x1000mm
KIT0121000



218x55x500 mm
KIT0121012



218x55x1000 mm
KIT0121013



218x55x70 mm
KIT0121015



90° 218x55 mm
KIT0121016



227x94x80mm
KIT0121001



15° 227x138x94
KIT0121002



Ø158x59mm
KIT0121003



90° 227x288x94mm
KIT0121004



218x55x590 mm
KIT0121017

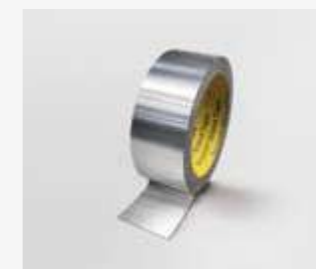

50 mm x 25 m
KIT0161453



90° 227x94mm
KIT0121005



90° - Ø157
KIT0121006



227x94 - Ø146mm
KIT0121007



227x94 - Ø153mm
KIT0121008



Ø150x240 mm
KIT0161457

Per evitare la creazione di condensa e il ritorno della stessa verso la fonte di espulsione dell'aria, consigliamo di installare questo componente lungo la condotta di uscita, facendo attenzione di posizionarlo in orizzontale per assicurarne un corretto funzionamento.

To avoid the formation of condensate and the flowback towards the source of air output, we advise installing this component along the outlet pipe, taking care to position it horizontally to ensure correct operation.

Nel caso di gruppo motore remoto INLINE l'accessorio deve essere installato dopo il motore stesso.

The accessory must be installed on the motor if there is an INLINE remote motor unit.



int 216x82 / est 290x160 mm
KIT0121009



190x190 - Ø147mm
KIT0121010



227x94x560 mm
KIT0126810

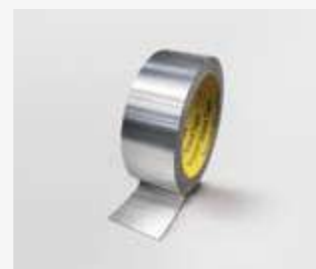

50 mm x 25 m
KIT0161453

BUILT IN

La tradizionale installazione a scomparsa permette di creare un ambiente uniforme e omogeneo, senza interruzioni. Per chi ricerca il massimo allineamento e la totale linearità, le cappe built in sono la soluzione in grado di personalizzare al meglio la propria cucina. Il perfetto incasso tra i pensili consente una continuità di sguardo, celando all'interno del prodotto il cuore tecnologico. L'innovativo sistema anticondensa no-drip assicura la migliore protezione ai pensili, catturando le gocce di vapore in risalita, prima che si dispendano nell'ambiente. Alleate tanto discrete quanto preziose.

The traditional concealed installation allows you to create a uniform and seamless environment, with no interruptions. For anyone looking for maximum alignment and total linearity, built-in hoods are the solution to stamping your own style on the kitchen. The perfect fit between the wall units allows for continuity, concealing the technology behind the extraction unit inside the hood. The innovative no-drip, anti-condensate system ensures the best protection for the wall units, capturing the drops of rising steam before they are dispersed in the air. Discrete and sophisticated allies.



BOXIN NO DRIP

ELICA DESIGN CENTER

60 - 90 - 120 cm
Aspirante Duct-out
Acciaio inox Stainless steel

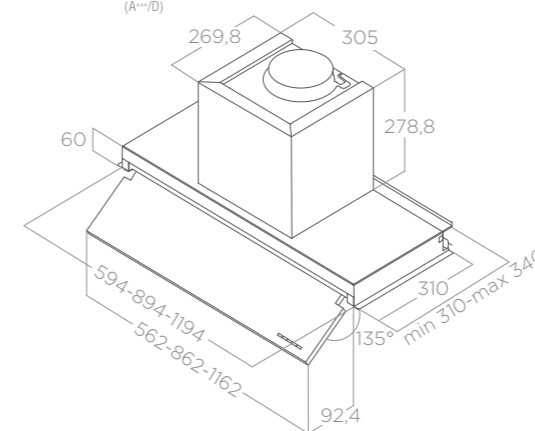
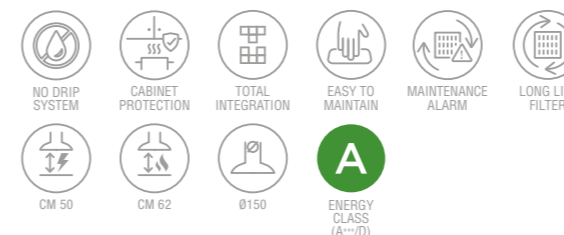

La prima cappa incasso di Elica per risolvere il problema della condensa con sistemi meccanici ed elettrici. Un sistema di resistenze permette al prodotto di riscaldarsi e l'inclinazione dei filtri facilita la raccolta di eventuali gocce d'acqua residue in un'apposita vaschetta. Il sistema è studiato per evitare la caduta delle gocce sul piano cottura e per salvare i pensili dal vapore.

Elica's first built-in hood that solves the problem of condensate with mechanical and electrical systems. A resistance system allows the product to heat up, while its tilted filters facilitate the collection of any possible residual water droplets into a specific tray. The system has been designed to prevent dripping on the hob, as well as protect wall units from steam.

ILLUMINAZIONE LIGHTING

Tipo Type	LED 2x2,5W
Intensità Intensity	381 LUX
Temperatura Temperature	3500 K

PERFORMANCE PERFORMANCE

Comandi Controls	Pulsantiera elettronica 3V+I 3S+B Electronic push button
Portata intensiva Booster airflow	680 m ³ /h
Livello sonoro min-max Noise level min-max	34 - 66 db(A)
Assorbimento totale Total absorption	255 W

Filtro grassi alluminio incluso Grease aluminium filter included

ACCESSORI ACCESSORIES

Filtro carbone Charcoal filter	CFC0140343
Filtro carbone rigenerabile Regenerable charcoal filter	CFC0162221
Kit griglia diffusore aria Ø150 mm Air diffuser grid kit 150mm	KIT0162617
Kit camino H12 IX Chimney kit H12 IX	KIT0091876
Kit camino telescopico h18,5+h18,5 IX Telescopic chimney kit h18,5+h18,5 IX	KIT0141458

MODELLI MODELS

BOXIN NO DRIP IX/A/60	PRF0157712A
BOXIN NO DRIP IX/A/90	PRF0156613A
BOXIN NO DRIP IX/A/120	PRF0157280A

BOXIN DRY

DESIGN FABRIZIO CRISÀ





BOXIN DRY

DESIGN FABRIZIO CRISÀ

60 - 75 - 90 - 120 cm
Aspirante Duct-out
Acciaio inox Stainless steel

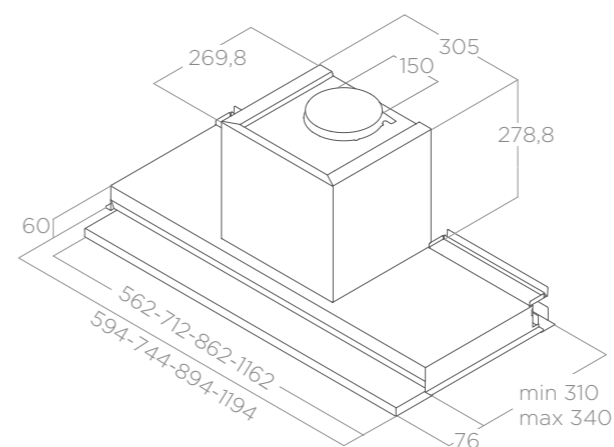
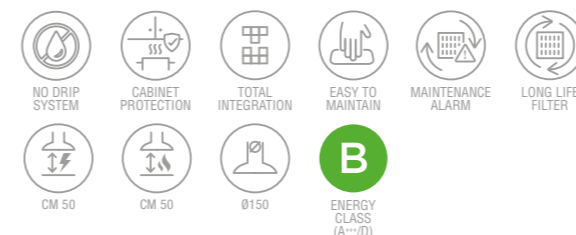

Il design del prodotto è stato pensato per ridurre la capacità di contatto del vapore generato dalla cottura con le superfici della cappa, prevenendo la formazione della condensa attraverso un sistema meccanico ed evitando fastidiosi sgocciolamenti sul piano cottura.

The product was designed to reduce the contact of cooking vapor with the hood surfaces, thus preventing the formation of condensation through a mechanical system, avoiding bothersome dripping onto the hob.

ILLUMINAZIONE LIGHTING

Tipo Type	LED 2x2.1W - LED 3x2.1W (120cm)
Intensità Intensity	181 LUX - 211 LUX (120cm)
Temperatura Temperature	3500 K

PERFORMANCE PERFORMANCE

Comandi Controls	Pulsantiera elettronica 3V+I 3S+B Electronic push button
Portata intensiva Booster airflow	700 m ³ /h
Livello sonoro min-max Noise level min-max	52 - 67 db(A)
Assorbimento totale Total absorption	255 W

Filtri grassi inox incluso Stainless steel grease filters included

ACCESSORI ACCESSORIES

Filtro carbone Charcoal filter	CFC0140343
Filtro carbone rigenerabile Regenerable charcoal filter	CFC0162221
Kit griglia diffusore aria Ø150 mm Air diffuser grid kit 150mm	KIT0162617
Kit camino H12 Chimney kit H12	KIT0091876
Kit camino H18,5+18,5 Chimney kit H18,5+18,5	KIT0141458

MODELLI MODELS

BOXIN DRY IX/A/60	PRF0181274
BOXIN DRY IX/A/75	PRF0181828
BOXIN DRY IX/A/90	PRF0181068
BOXIN DRY IX/A/120	PRF0181338



BOXIN ADVANCE

DESIGN FABRIZIO CRISÀ

60 - 90 - 120 cm
Aspirante Duct-out
Acciaio inox Stainless steel

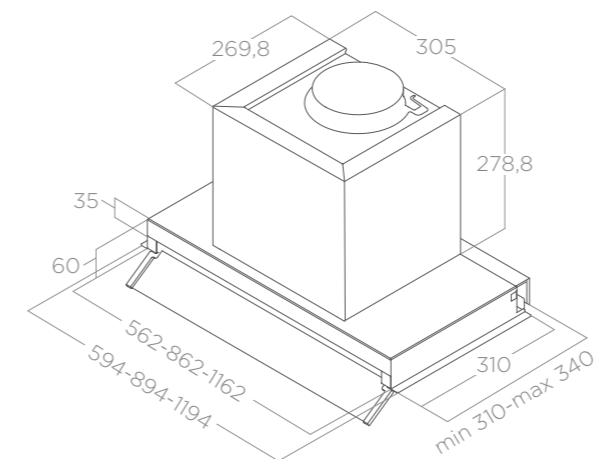
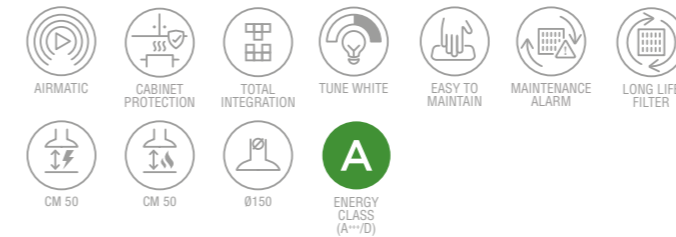

La cappa è dotata della funzione Airmatic che grazie ad un sensore intelligente permette la sua accensione in completa autonomia. Questo assicura un'aria pulita in casa in ogni momento della giornata e una maggiore salvaguardia del pensile e dei mobili della cucina. The hood is equipped with the Airmatic feature that thanks to a smart sensor, allows it to automatically power on. This guarantees clean air inside the home at all times of the day, as well as increased protection of cabinets and kitchen furnishings.

ILLUMINAZIONE LIGHTING

Tipo Type	STRIP LED 1X7W
Intensità Intensity	421 LUX
Temperatura Temperature	3000 - 3500 - 4000 K

PERFORMANCE PERFORMANCE

Comandi Controls	Pulsantiera elettronica 3V+I 3S+B Electronic push button
Portata intensiva Booster airflow	730 m ³ /h
Livello sonoro min-max Noise level min-max	50 - 64 db(A)
Assorbimento totale Total absorption	257 W

Filtri grassi inox incluso Stainless steel grease filters included

ACCESSORI ACCESSORIES

Filtro carbone Charcoal filter	CFC0140343
Filtro carbone rigenerabile Regenerable charcoal filter	CFC0162221
Kit griglia diffusore aria Ø150 mm Air diffuser grid kit 150mm	KIT0162617
Kit camino H12 Chimney kit H12	KIT0091876
Kit camino H18,5+18,5 Chimney kit H18,5+18,5	KIT0141458

MODELLI MODELS

BOXIN ADVANCE IX/A/60	PRF0180599
BOXIN ADVANCE IX/A/90	PRF0181497
BOXIN ADVANCE IX/A/120	PRF0182703



BOXIN PLUS

ELICA DESIGN CENTER

60 - 90 - 120 cm
Aspirante Duct-out
Acciaio inox + vetro bianco
Stainless steel + white glass

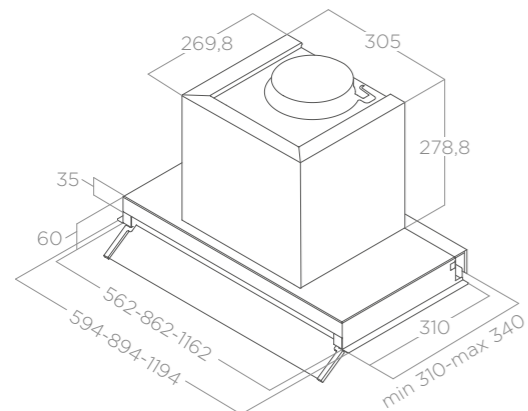
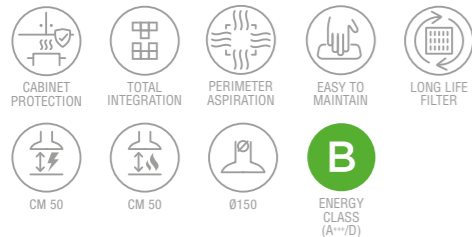

ILLUMINAZIONE LIGHTING	
Tipo Type	Led 2x2,5 W
Intensità Intensity	381 LUX
Temperatura Temperature	3500 K

PERFORMANCE PERFORMANCE	
Comandi Controls	Rotativo meccanico 3V 3S Mechanical rotative
Portata massima Max airflow	610 m ³ /h
Livello sonoro min-max Noise level min-max	49 - 70 db(A)
Assorbimento totale Total absorption	255 W

Filtro grassi alluminio incluso Grease aluminium filter included

ACCESSORI ACCESSORIES	
Filtro carbone Charcoal filter	CFC0140343
Filtro carbone rigenerabile Regenerable charcoal filter	CFC0162221
Kit griglia diffusore aria Ø150 mm Air diffuser grid kit 150mm	KIT0162617
Kit camino H12 Chimney kit H12	KIT0091876
Kit camino H18,5+18,5 Chimney kit H18,5+18,5	KIT0141458

MODELLI MODELS	
BOX IN PLUS IXGL/A/60	PRF0097795A
BOX IN PLUS IXGL/A/90	PRF0097796A
BOX IN PLUS IXGL/A/120	PRF0097797A



BOXIN IX



BOXIN BL

BOXIN

ELICA DESIGN CENTER

60 - 75 - 90 - 120 cm
Aspirante Duct-out
Acciaio inox, nero effetto soft touch
Stainless steel, black soft touch effect

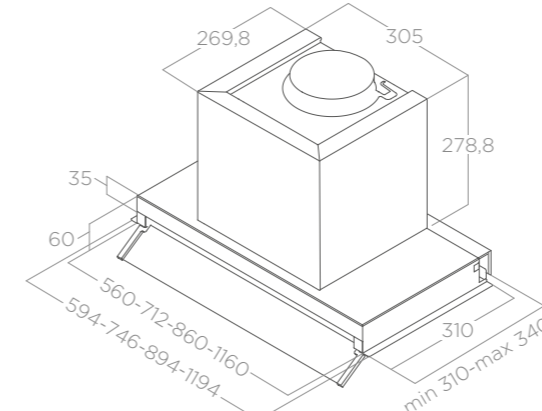

ILLUMINAZIONE LIGHTING	
Tipo Type	Led 2x2,5 W
Intensità Intensity	381 LUX
Temperatura Temperature	3500 K

PERFORMANCE PERFORMANCE		
Comandi Controls	Rotativo meccanico 3V 3S Mechanical rotative	
	STD	LUX
Portata massima Max airflow	370 m ³ /h	620 m ³ /h
Livello sonoro min-max Noise level min-max	48 - 67 db(A)	50 - 70 db(A)
Assorbimento totale Total absorption	95 W	255 W

Filtro grassi alluminio incluso Grease aluminium filter included

ACCESSORI ACCESSORIES		
Filtro carbone (*) Charcoal filter (*)	CFC0140343	
Filtro carbone rigenerabile (*) Regenerable charcoal filter (*)	CFC0162221	
Filtro carbone Charcoal filter	CFC0141497	
Kit griglia diffusore aria Ø150 mm Air diffuser grid kit 150mm	KIT0162617	
Kit camino H12 Chimney kit H12	KIT0091876	
Kit camino H18,5+18,5 Chimney kit H18,5+18,5	KIT0141458	

MODELLI MODELS	
BOXIN IX/A/60	PRF0097835B
BOXIN IX/A/90	PRF0097839B
BOXIN IX/A/120	PRF0097842B
BOXIN LX/IX/A/60 (*)	PRF0114760A
BOXIN LX/IX/A/75 (*)	PRF0178649
BOXIN LX/IX/A/90 (*)	PRF0114761A
BOXIN LX/IX/A/120 (*)	PRF0114762A
BOXIN LX/BL MAT/A/60 (*)	PRF0172166
BOXIN LX/BL MAT/A/90 (*)	PRF0172167
BOXIN LX/BL MAT/A/120 (*)	PRF0172168



CT35 PRO

ELICA DESIGN CENTER

60 - 90 - 120 cm
Aspirante Duct-out
Acciaio inox Stainless steel

- TOTAL INTEGRATION
- DELAY SWITCH OFF
- EASY TO MAINTAIN
- MAINTENANCE ALARM
- BACK ASPIRATION
- CM 50
- CM 65
- Ø150
- ENERGY CLASS (A+/D)

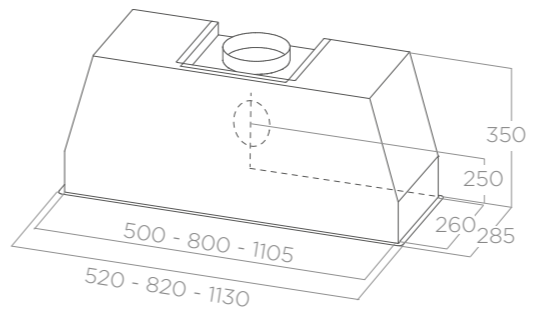

ILLUMINAZIONE LIGHTING

Tipo Type	STRIP LED 2x3W		
	60cm	90cm	120cm
Intensità Intensity	121 LUX	97 LUX	73 LUX
Temperatura Temperature	4200 K	4200 K	4200 K

PERFORMANCE PERFORMANCE

Comandi Controls	Pulsantiera elettronica 3V+I 3S+B Electronic push button		
	60cm	90cm	120cm
Portata intensiva Booster airflow	650 m³/h	750 m³/h	780 m³/h
Livello sonoro min-max Noise level min-max	51 - 73 db(A)	50 - 69 db(A)	52 - 69 db(A)
Assorbimento totale Total absorption	281 W	281 W	281 W

Filtri Grassi Professionali Inox incluso
Professional stainless steel grease filter included

ACCESSORI ACCESSORIES

Motore remoto esterno (GME11) Remote external motor (GME11)	PRF0006209A
Motore remoto esterno (GME22 A) Remote external motor (GME22 A)	PRF0179706

MODELLI MODELS

CT35 PRO IX/A/60	PRF0183203
CT35 PRO IX/A/90	PRF0183209
CT35 PRO IX/A/120	PRF0183210
CT35 PRO GME IX/A/60	PRF0183213
CT35 PRO GME IX/A/90	PRF0183218
CT35 PRO GME IX/A/120	PRF0183219



COSA MANCA: PANE
BISCOTTI
FRAGOLE
MELANZANE
ZUCCHINE

HIDDEN 2.0 @
DESIGN FABRIZIO CRISÀ



HIDDEN 2.0 @ BLGL



HIDDEN 2.0 @ IX



Built-in

HIDDEN 2.0 @

DESIGN FABRIZIO CRISÀ

ELICA CONNECT

60 - 80 cm

Aspirante Duct-out

Acciaio inox, nero effetto soft touch + vetro nero

Stainless steel, black soft touch effect + black glass

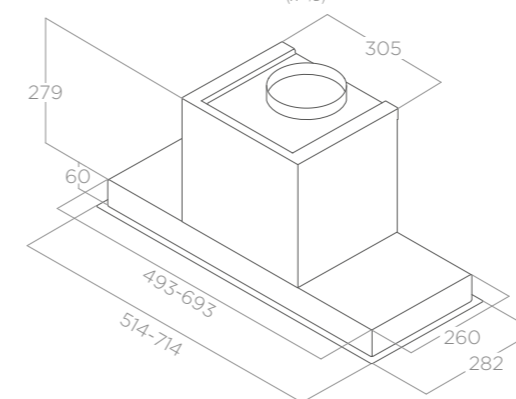
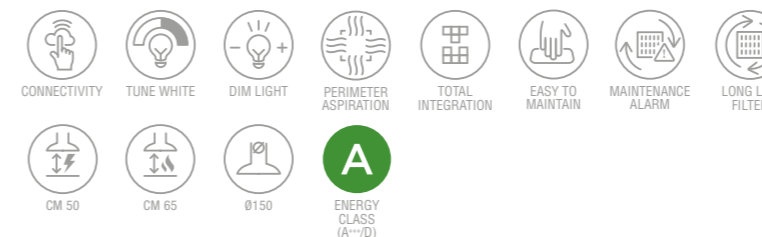

Hidden 2.0 @ consente all'utente di sentirsi più libero e di avere più tempo per concentrarsi sulle operazioni di cottura grazie al suo sistema wireless intelligente. La cappa può essere utilizzata tramite la app Elica Connect o uno smart speaker ricevendo e dando informazioni.

Hidden 2.0 @ heightens the user's sense of freedom, offering more time to concentrate on cooking thanks to the smart wireless system. The hood can be used through the Elica Connect app or with smart speaker, giving and receiving information.

ILLUMINAZIONE LIGHTING

Tipo Type	STRIP LED 1x7W
Intensità Intensity	309 LUX
Temperatura Temperature	2700 - 6500 K

PERFORMANCE PERFORMANCE

Comandi Controls	Pulsantiera elettronica 3V+I 3S+B Electronic push button
Portata intensiva Booster airflow	700 m ³ /h
Livello sonoro min-max Noise level min-max	51 - 67 db(A)
Assorbimento totale Total absorption	277 W

Filtro grassi alluminio incluso Grease aluminium filter included

ACCESSORI ACCESSORIES

Filtro carbone Charcoal filter	CFC0140343
Filtro carbone rigenerabile Regenerable charcoal filter	CFC0162221
Kit griglia diffusore aria Ø150 mm Air diffuser grid kit 150mm	KIT0162617
Kit camino telescopico h18,5+h18,5 Telescopic chimney kit h18,5+h18,5	KIT0141458

MODELLI MODELS

HIDDEN 2.0 @ IX/A/52	PRF0164340
HIDDEN 2.0 @ IX/A/72	PRF0164356
HIDDEN 2.0 @ BLGL/A/52	PRF0164361
HIDDEN 2.0 @ BLGL/A/72	PRF0164391



Da oggi anche le cappe a incasso sono connesse al Web
Even built-in hoods connected to the Web, starting now

ELICA CONNECT

Hidden 2.0 @ è la prima cappa a incasso connessa in wi-fi di Elica, un modello dal design estremamente pulito che rende il prodotto completamente integrato nel design della tua cucina.

Con questo prodotto, Elica continua il suo percorso nel mondo dell'IoT, rendendo più semplice la vita in cucina: Hidden 2.0 @ permette una maggiore libertà di movimento e più tempo per concentrarsi sulle operazioni di cottura.

La cappa può essere gestita tramite la app Elica Connect, mediante la quale è possibile attivare l'aspirazione e regolare l'intensità e il calore della luce, da un tono di bianco più freddo ed elegante, ad una luce più calda ed avvolgente, creando così l'atmosfera desiderata.

La app dedicata ed estremamente user friendly aggiorna l'utente con informazioni utili sullo stato del prodotto o su eventuali interventi necessari come la manutenzione o la sostituzione dei filtri. Inoltre, è possibile collegare Hidden 2.0 @ con gli smart speakers più diffusi per avere a disposizione il controllo vocale.



Hidden 2.0 @ is Elica's first built-in hood with Wi-Fi connection, a model distinguished by its extremely clean design, allowing its smooth and complete integration into your kitchen design.

Through this product, Elica continues its journey through the IoT world, making life in the kitchen even simpler: Hidden 2.0 @ allows greater freedom of movement and more time to concentrate on your cooking.

The hood can be managed through the Elica Connect app, using which it's possible to adjust the intensity and warmth of the light, whether cooler and more elegant or softer and more inviting, thus perfectly creating your desired atmosphere.

The dedicated and extremely user-friendly app updates the user with helpful information

regarding the status of the product or any necessary servicing, such as filter maintenance or replacement. Moreover, Hidden 2.0 @ can be connected with the most popular smart speakers for access to voice control.

Grandi performance in una soluzione salvaspazio
Huge performance in a space-saving solution



Hidden 2.0 @ è stata progettata per garantire le migliori performance di funzionamento in uno spazio contenuto. La ridotta dimensione dell'ingombro interno, infatti, consente di poter usufruire comunque dello spazio nel pensile, utilissimo per riporre barattoli o libri di ricette.

La cappa diventa parte integrante dello spazio e garantisce ottime performance grazie ad un sistema di aspirazione perimetrale che consente una perfetta captazione dei fumi.

Una Strip Led illumina in modo diffuso e uniforme il piano cottura e permette la regolazione di intensità della luce oltre che della tonalità di colore, da un tono di bianco più freddo ad una luce più calda, per avere sempre la giusta atmosfera e il miglior comfort visivo.



Hidden 2.0 @ is designed to guarantee best performance in the smallest possible space. Its reduced overall size in fact allows use of the cabinet space regardless, useful in storing jars or recipe books.

The hood becomes an integral part of the space and guarantees best performance also thanks to a perimeter extraction system, which perfectly captures the fumes.

A LED strip illuminates the hob with diffused and even lighting, and allows adjustment of the light intensity and colour, from cool white to a warmer shade, ensuring the perfect atmosphere and best visual comfort at all times.

Linearità in cucina
Linearity in the kitchen

Hidden 2.0 @ è stata disegnata per scomparire nel pensile. Il pannello centrale, in vetro o acciaio, nasconde le parti funzionali del prodotto mantenendo l'estetica pulita e integrandosi perfettamente nel cabinet. Il risultato è un effetto lineare della cucina, senza elementi di discontinuità, perfetto per chi ama uno stile sobrio e essenziale.

Hidden 2.0 @ is designed to disappear into the cabinet. The central panel in either glass or steel hides the functional elements of the product while maintaining a clean look and perfectly blending in with the cabinet. The result is a totally linear kitchen effect without any discontinuity, perfect for lovers of an understated and essential style.





HIDDEN ADVANCE

DESIGN FABRIZIO CRISÀ

60 - 80 cm

Aspirante Duct-out

Acciaio inox, nero effetto soft touch

Stainless steel, black soft touch effect

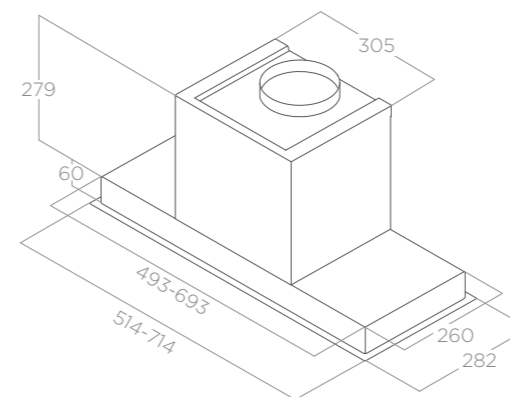
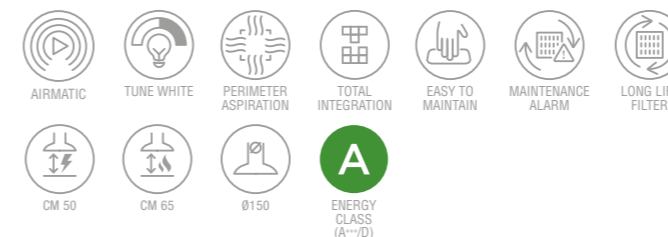

La cappa è dotata della funzione Airmatic che grazie ad un sensore intelligente permette la sua accensione in completa autonomia. Questo assicura un'aria pulita in casa in ogni momento della giornata e una maggiore salvaguardia del pensile e dei mobili della cucina. The hood is equipped with the Airmatic feature, which thanks to a smart sensor allows it to power on automatically. This guarantees clean air inside the home at any moment of the day and greater protection of the kitchen cabinets and furniture.

ILLUMINAZIONE LIGHTING

Tipo Type	STRIP LED 1x7W
Intensità Intensity	477 LUX
Temperatura Temperature	3000-3500-4000 K

PERFORMANCE PERFORMANCE

Comandi Controls	Pulsantiera elettronica 3V+I 3S+B Electronic push button
Portata intensiva Booster airflow	690 m ³ /h
Livello sonoro min-max Noise level min-max	51 - 67 db(A)
Assorbimento totale Total absorption	277 W

Filtro grassi alluminio incluso Grease aluminium filter included

ACCESSORI ACCESSORIES

Filtro carbone Charcoal filter	CFC0140343
Filtro carbone rigenerabile Regenerable charcoal filter	CFC0162221
Kit griglia diffusore aria Ø150 mm Air diffuser grid kit 150mm	KIT0162617
Kit camino telescopico h18,5+h18,5 Telescopic chimney kit h18,5+h18,5	KIT0141458

MODELLI MODELS

HIDDEN ADVANCE IX/A/52	PRF0180299
HIDDEN ADVANCE IX/A/72	PRF0182867
HIDDEN ADVANCE BL MAT/A/52	PRF0183971
HIDDEN ADVANCE BL MAT/A/72	PRF0184107



HIDDEN 2.0

DESIGN FABRIZIO CRISÀ

60 - 80 cm

Aspirante Duct-out

Acciaio inox, acciaio inox + vetro bianco
Stainless steel, stainless steel + white glass

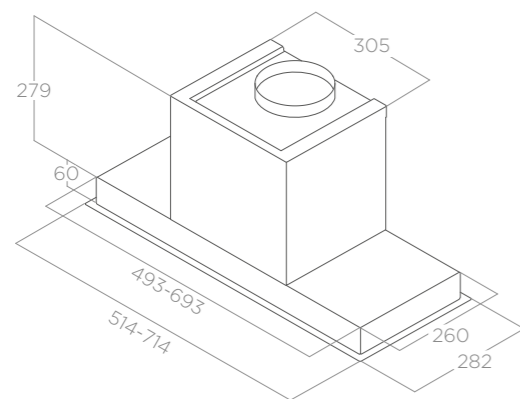
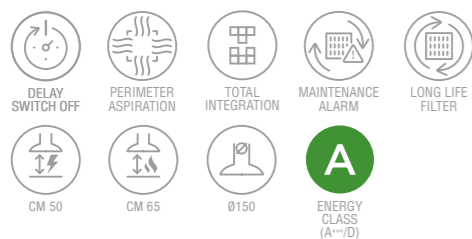

ILLUMINAZIONE LIGHTING	
Tipo Type	Strip Led 1x7 W
Intensità Intensity	365 LUX
Temperatura Temperature	3500 K
PERFORMANCE PERFORMANCE	
Comandi Controls	Pulsantiera elettronica 3V+I 3S+B Electronic push button
Portata intensiva Booster airflow	700 m ³ /h
Livello sonoro min-max Noise level min-max	51 - 67 db(A)
Assorbimento totale Total absorption	277 W
Filtro grassi alluminio incluso Grease aluminium filter included	
ACCESSORI ACCESSORIES	
Filtro carbone Charcoal filter	CFC0140343
Filtro carbone rigenerabile Regenerable charcoal filter	CFC0162221
Kit griglia diffusore aria Ø150 mm Air diffuser grid kit 150mm	KIT0162617
Kit camino telescopico h18,5+h18,5 Telescopic chimney kit h18,5+h18,5	KIT0141458
MODELLI MODELS	
HIDDEN 2.0 IX/A/52	PRF0092333A
HIDDEN 2.0 IX/A/72	PRF0095073A
HIDDEN 2.0 IXGL/A/52	PRF0097676A
HIDDEN 2.0 IXGL/A/72	PRF0097708A



LANE

DESIGN FABRIZIO CRISÀ

60 - 80 cm

Aspirante Duct-out

Acciaio inox, nero effetto soft touch, bianco, silver
Stainless steel, black soft touch effect, white, silver

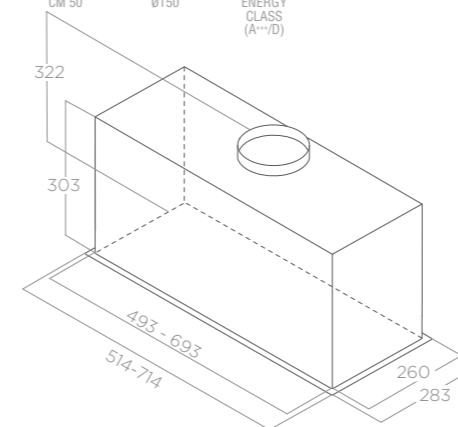
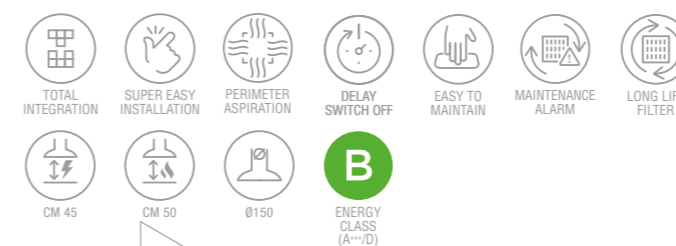

Il prodotto è equipaggiato con un sistema di fissaggio brevettato. Tramite due clip presenti sui fianchi del corpo cappa, con solo 2 viti dal basso, è possibile montarla nel mobile in meno di un minuto. The product is equipped with a patented mounting system. Through the use of two clips found on the sides of the hood body and with only two bottom screws, it can be installed into the cabinet in less than one minute.

ILLUMINAZIONE LIGHTING	
Tipo Type	STRIP LED 1x7W
Intensità Intensity	365 LUX
Temperatura Temperature	3500 K
PERFORMANCE PERFORMANCE	
Comandi Controls	Pulsantiera elettronica 3V+I 3S+B Electronic push button
Portata intensiva Booster airflow	650 m ³ /h
Livello sonoro min-max Noise level min-max	49 - 65 db(A)
Assorbimento totale Total absorption	257 W
Filtro grassi alluminio incluso Grease aluminium filter included	
ACCESSORI ACCESSORIES	
Filtro carbone Charcoal filter	CFC0140343
Filtro carbone rigenerabile Regenerable charcoal filter	CFC0162221
Kit griglia diffusore aria Ø150 mm Air diffuser grid kit 150mm	KIT0162617
MODELLI MODELS	
LANE IX/A/52	PRF0157333
LANE IX/A/72	PRF0157377
LANE BL MAT/A/52	PRF0165830
LANE BL MAT/A/72	PRF0165834
LANE WH/A/52	PRF0157357
LANE WH/A/72	PRF0157394
LANE GR/A/52	PRF0157369
LANE GR/A/72	PRF0157404



FOLD S

ELICA DESIGN CENTER

60 - 80 cm
Aspirante Duct-out
Acciaio inox
Stainless steel

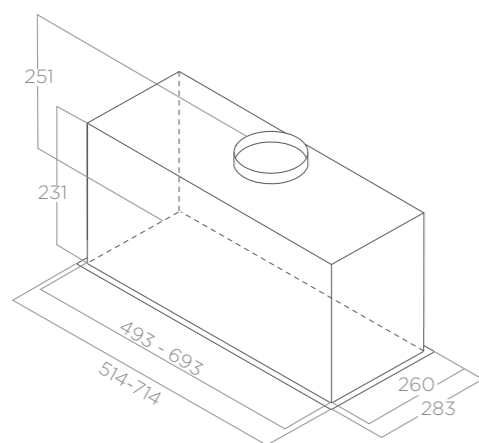
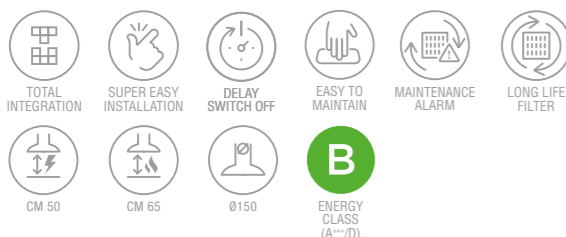

Il prodotto è equipaggiato con un sistema di fissaggio brevettato. Tramite due clip presenti sui fianchi del corpo cappa, con solo 2 viti dal basso, è possibile montarla nel mobile in meno di un minuto. The product is equipped with a patented mounting system. Through the use of two clips found on the sides of the hood body and with only two bottom screws, it can be installed into the cabinet in less than one minute.

ILLUMINAZIONE LIGHTING	
Tipo Type	STRIP LED 1X7W
Intensità Intensity	477 LUX
Temperatura Temperature	3500 K

PERFORMANCE PERFORMANCE	
Comandi Controls	Pulsantiera elettronica 3V+I 3S+B Electronic push button
Portata intensiva Booster airflow	710 m ³ /h
Livello sonoro min-max Noise level min-max	53 - 66 db(A)
Assorbimento totale Total absorption	257 W

Filtri grassi inox incluso Stainless steel grease filters included

ACCESSORI ACCESSORIES	
Filtro carbone Charcoal filter	CFC0140343
Filtro carbone rigenerabile Regenerable charcoal filter	CFC0162221
Kit griglia diffusore aria Ø150 mm Air diffuser grid kit 150mm	KIT0162617

MODELLI MODELS	
FOLD S IX/A/52	PRF0181962
FOLD S IX/A/72	PRF0181963



FOLD

ELICA DESIGN CENTER

60 - 80 cm
Aspirante Duct-out
Silver, nero
Silver, black

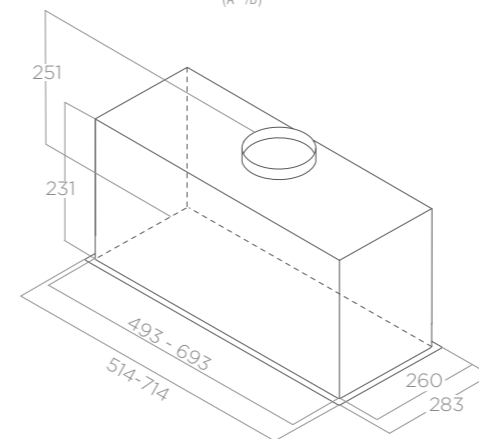
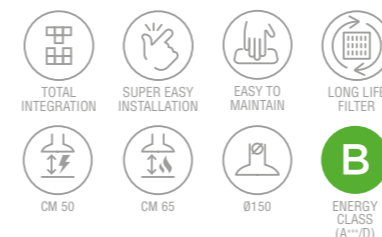

Il prodotto è equipaggiato con un sistema di fissaggio brevettato. Tramite due clip presenti sui fianchi del corpo cappa, con solo 2 viti dal basso, è possibile montarla nel mobile in meno di un minuto. The product is equipped with a patented mounting system. Through the use of two clips found on the sides of the hood body and with only two bottom screws, it can be installed into the cabinet in less than one minute.

ILLUMINAZIONE LIGHTING	
Tipo Type	LED 2X2.1W
Intensità Intensity	221 LUX
Temperatura Temperature	3500 K

PERFORMANCE PERFORMANCE	
Comandi Controls	Pulsantiera soft light 3V 3S Soft light push button
Portata intensiva Booster airflow	600 m ³ /h
Livello sonoro min-max Noise level min-max	46 - 65 db(A)
Assorbimento totale Total absorption	180 W

Filtro grassi alluminio incluso Grease aluminium filter included

ACCESSORI ACCESSORIES	
Filtro carbone Charcoal filter	CFC0140343
Filtro carbone rigenerabile Regenerable charcoal filter	CFC0162221
Kit griglia diffusore aria Ø150 mm Air diffuser grid kit 150mm	KIT0162617

MODELLI MODELS	
FOLD GR/A/52	PRF0180808
FOLD GR/A/72	PRF0180820
FOLD BL/A/52	PRF0181960
FOLD BL/A/72	PRF0181961



ERA S

ELICA DESIGN CENTER

60 - 80 cm
Aspirante Duct-out
Acciaio inox Stainless steel

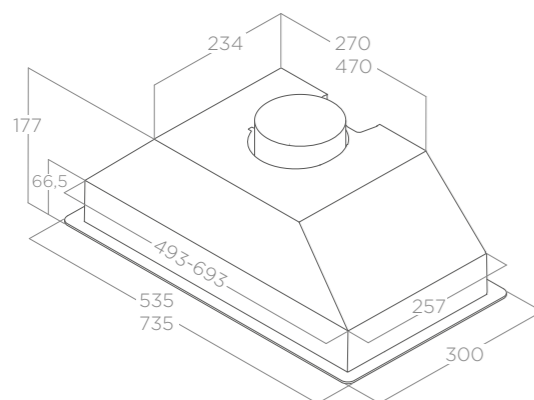

ILLUMINAZIONE LIGHTING

Tipo Type	Led 2x3 W
Intensità Intensity	73 LUX
Temperatura Temperature	2700 K

PERFORMANCE PERFORMANCE

Comandi Controls	Rotativo meccanico 3V 3S Mechanical rotative
Portata massima Max airflow	428 m ³ /h
Livello sonoro min-max Noise level min-max	57 - 68 db(A)
Assorbimento totale Total absorption	121 W

Filtri grassi inox incluso Stainless steel grease filters included

ACCESSORI ACCESSORIES

Filtro carbone Charcoal filter	CFC0141571
--------------------------------	------------

MODELLI MODELS

ERA S IX/A/52	PRF0142886
ERA S IX/A/72	PRF0142744



ERA C IX 72



ERA C WH 52



ERA C BL 52

ERA C

ELICA DESIGN CENTER

60 - 80 cm
Aspirante Duct-out
Acciaio inox, bianco, nero Stainless steel, white, black

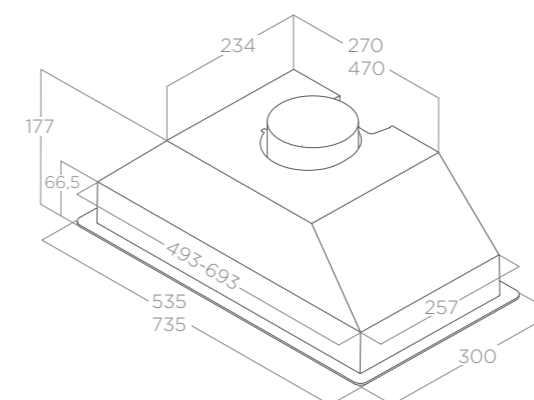

ILLUMINAZIONE LIGHTING

Tipo Type	Led 2x3 W
Intensità Intensity	73 LUX
Temperatura Temperature	2700 K

PERFORMANCE PERFORMANCE

Comandi Controls	Pulsantiera meccanica 3V 3S Mechanical push button
Portata massima Max airflow	368 m ³ /h
Livello sonoro min-max Noise level min-max	62 - 67 db(A)
Assorbimento totale Total absorption	146 W

Filtro grassi alluminio incluso Grease aluminium filter included

ACCESSORI ACCESSORIES

Filtro carbone Charcoal filter	CFC0141571
--------------------------------	------------

MODELLI MODELS

ERA C IX/A/52	PRF0142723
ERA C IX/A/72	PRF0142741
ERA C WH/A/52	PRF0142716
ERA C WH/A/72	PRF0142728
ERA C BL/A/52	PRF0166822
ERA C BL/A/72	PRF0166823



ERA

ELICA DESIGN CENTER

60 - 80 cm
Aspirante Duct-out
Silver Silver

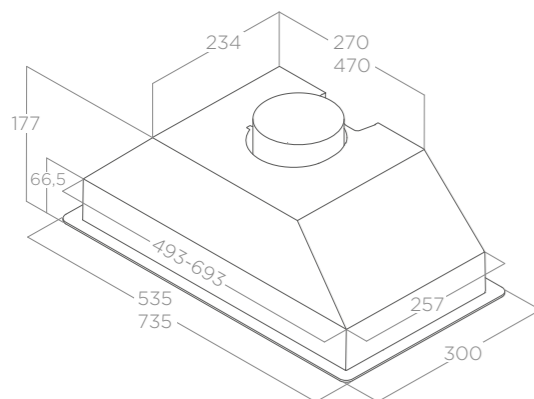
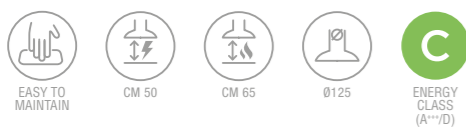

ILLUMINAZIONE LIGHTING	
Tipo Type	Led 2x3 W
Intensità Intensity	78 LUX
Temperatura Temperature	2700 K
PERFORMANCE PERFORMANCE	
Comandi Controls	Slider meccanico 3V 3S Mechanical slider
Portata massima Max airflow	224 m ³ /h
Livello sonoro min-max Noise level min-max	45 - 54 db(A)
Assorbimento totale Total absorption	81 W

Filtro grassi alluminio incluso Grease aluminium filter included

ACCESSORI ACCESSORIES	
Filtro carbone Charcoal filter	CFC0141571

MODELLI MODELS	
ERA GR/A/52	PRF0142633
ERA GR/A/72	PRF0142701



LEVER

ELICA DESIGN CENTER

60 - 90 - 120 cm
Aspirante Duct-out
Acciaio inox + vetro
Stainless steel + glass

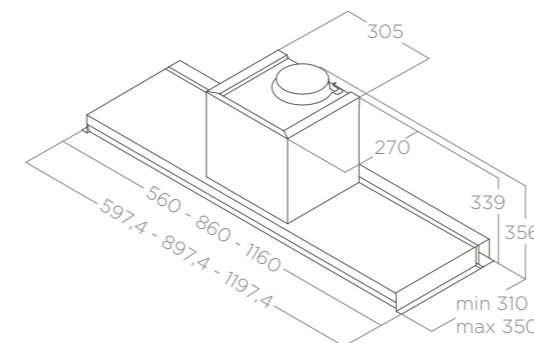
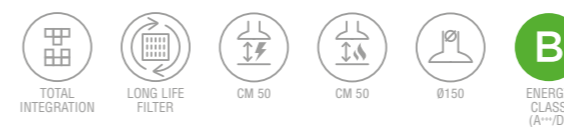

ILLUMINAZIONE LIGHTING	
Tipo Type	LED 2x2,5W
Intensità Intensity	145 LUX
Temperatura Temperature	3500 K
PERFORMANCE PERFORMANCE	
Comandi Controls	Pulsantiera meccanica 3V 3S Mechanical push button
Portata massima Max airflow	603 m ³ /h
Livello sonoro min-max Noise level min-max	46 - 67 db(A)
Assorbimento totale Total absorption	255 W

Filtro grassi alluminio incluso Grease aluminium filter included

ACCESSORI ACCESSORIES	
Filtro carbone Charcoal filter	CFC0140343
Filtro carbone rigenerabile Regenerable charcoal filter	CFC0162221
Kit griglia diffusore aria Ø150 mm Air diffuser grid kit 150mm	KIT0162617
Kit camino H12 IX Chimney kit H12 IX	KIT0091876
Kit camino telescopico h18,5+h18,5 IX Telescopic chimney kit h18,5+h18,5 IX	KIT0141458

MODELLI MODELS	
LEVER IX/A/56	PRF0160153
LEVER IX/A/86	PRF0160152
LEVER IX/A/116	PRF0163362

Prodotto con un design molto semplice ed essenziale si nasconde completamente nel pensile. È dotato di una visiera frontale che protegge l'anta durante il processo di cottura convogliando il vapore attraverso la zona di aspirazione.

A very simple and essential design characterizes this appliance, which is completely hidden in the cabinet. It is equipped with a frontal visor that protects the door during cooking, conveying vapours through the extraction area.



GLASS OUT

DESIGN FABRIZIO CRISÀ

60 - 90 cm
Aspirante Duct-out
Acciaio inox + vetro
Stainless steel + glass

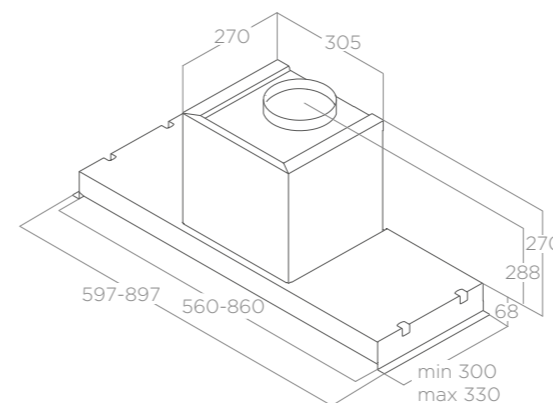
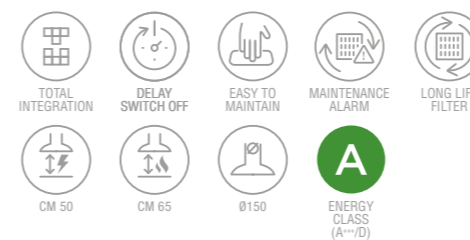

ILLUMINAZIONE LIGHTING

Tipo Type	Strip Led 1x7 W
Intensità Intensity	141 LUX
Temperatura Temperature	4000 K

PERFORMANCE PERFORMANCE

Comandi Controls	Pulsantiera elettronica 3V+I 3S+B Electronic push button
Portata intensiva Booster airflow	560 m ³ /h
Livello sonoro min-max Noise level min-max	53 - 61 db(A)
Assorbimento totale Total absorption	227 W

Filtro grassi alluminio incluso Grease aluminium filter included

ACCESSORI ACCESSORIES

Filtro carbone Charcoal filter	CFC0140343
Filtro carbone rigenerabile Regenerable charcoal filter	CFC0162221
Kit griglia diffusore aria Ø150 mm Air diffuser grid kit 150mm	KIT0162617
Kit camino telescopico h18,5+h18,5 Telescopic chimney kit h18,5+h18,5	KIT0141458
Kit camino H12 IX Chimney kit H12 IX	KIT0091876

MODELLI MODELS

GLASS OUT IX/A/60	PRF0109787
GLASS OUT IX/A/90	PRF0109788



CIAK 2.0 S

ELICA DESIGN CENTER

60 - 90 cm
Aspirante Duct-out
Silver Silver

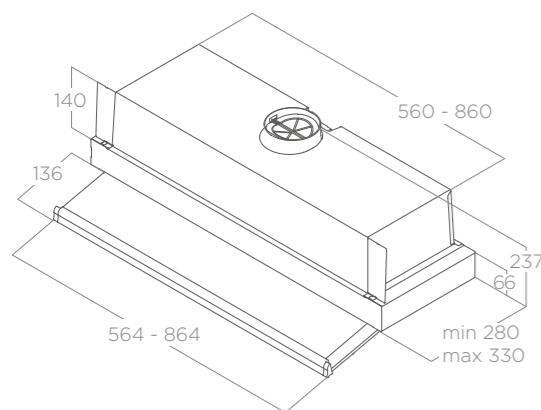

ILLUMINAZIONE LIGHTING

Tipo Type LED 2X2.5W
Intensità Intensity 141 LUX
Temperatura Temperature 3500 K

PERFORMANCE PERFORMANCE

Comandi Controls Slider meccanico 3V
3S Mechanical slider
Portata massima Max airflow 425 m³/h
Livello sonoro min-max Noise level min-max 57 - 69 db(A)
Assorbimento totale Total absorption 120 W

Filtro grassi alluminio incluso Grease aluminium filter included

ACCESSORI ACCESSORIES

Filtro carbone Charcoal filter CFC0141571

MODELLI MODELS

CIAK 2.0 S GR/A/60 PRF0181902
CIAK 2.0 S GR/A/90 PRF0181903



Prodotto con un design molto semplice ed essenziale si nasconde completamente nel pensile. È dotato di una visiera frontale che protegge l'anta durante il processo di cottura convogliando il vapore attraverso la zona di aspirazione. Its extremely simple and essential design allows it to completely disappear into the cabinet. The hood is equipped with a front visor that protects the cabinet door during cooking, conveying vapor through the extraction zone.



CIAK 2.0

ELICA DESIGN CENTER

60 - 90 cm
Aspirante Duct-out
Silver Silver

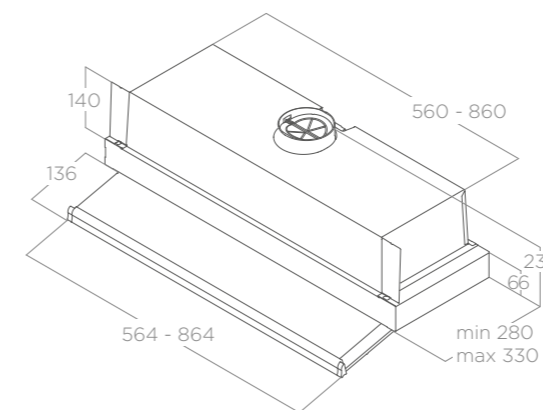
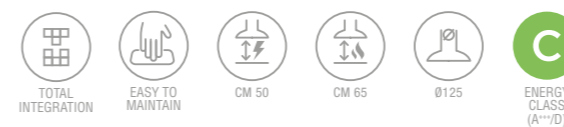

ILLUMINAZIONE LIGHTING

Tipo Type LED 2X3 W
Intensità Intensity 121 LUX
Temperatura Temperature 2700 K

PERFORMANCE PERFORMANCE

Comandi Controls Slider meccanico 3V
3S Mechanical slider
Portata massima Max airflow 225 m³/h
Livello sonoro min-max Noise level min-max 47 - 55 db(A)
Assorbimento totale Total absorption 121 W

Filtro grassi alluminio incluso Grease aluminium filter included

ACCESSORI ACCESSORIES

Filtro carbone Charcoal filter CFC0141571

MODELLI MODELS

CIAK 2.0 GR/A/60 PRF0181896
CIAK 2.0 GR/A/90 PRF0181898



Prodotto con un design molto semplice ed essenziale si nasconde completamente nel pensile. È dotato di una visiera frontale che protegge l'anta durante il processo di cottura convogliando il vapore attraverso la zona di aspirazione. Its extremely simple and essential design allows it to completely disappear into the cabinet. The hood is equipped with a front visor that protects the cabinet door during cooking, conveying vapor through the extraction zone.



ELITE 35

ELICA DESIGN CENTER

60 - 90 cm
Aspirante Duct-out
Silver + acciaio inox
Silver + stainless steel

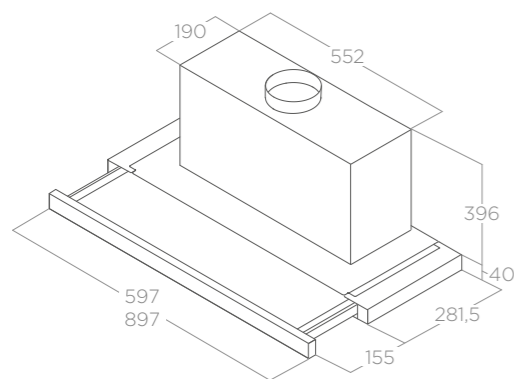
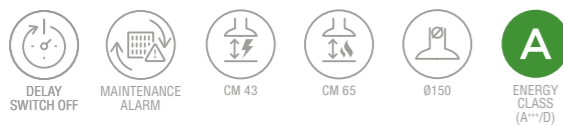

Il frontale del prodotto può essere facilmente rimosso e sostituito con uno di pari misura personalizzato con la stessa finitura utilizzata per il rivestimento dei mobili della cucina.

The front part of the product is easily removable and may be replaced with one of the same size, customizable in the same finish used on the kitchen cabinets.

ILLUMINAZIONE LIGHTING	
Tipo Type	Led 2x3 W
Intensità Intensity	49 LUX
Temperatura Temperature	2700 K

PERFORMANCE PERFORMANCE	
Comandi Controls	Pulsantiera elettronica 3V+I 3S+B Electronic push button
Portata intensiva Booster airflow	640 m ³ /h
Livello sonoro min-max Noise level min-max	46 - 63 db(A)
Assorbimento totale Total absorption	206 W

Filtro grassi alluminio incluso Grease aluminium filter included

ACCESSORI ACCESSORIES	
Filtro carbone Charcoal filter	CFC0140075
Kit griglia diffusore aria Ø150 mm Air diffuser grid kit 150mm	KIT0162617

MODELLI MODELS	
ELITE 35 GRIX/A/60	PRF0139077
ELITE 35 GRIX/A/90	PRF0139069



ELITE 14

ELICA DESIGN CENTER

60 - 90 cm
Aspirante Duct-out
Silver + acciaio inox
Silver + stainless steel

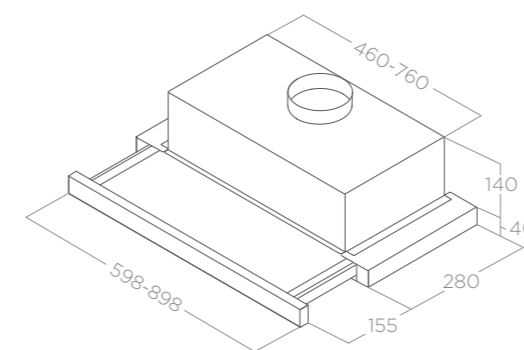

ILLUMINAZIONE LIGHTING	
Tipo Type	Led 2x3 W
Intensità Intensity	73 LUX
Temperatura Temperature	2700 K

PERFORMANCE PERFORMANCE	
Comandi Controls	Pulsantiera meccanica 3V 3S Mechanical push button
Portata massima Max airflow	304 m ³ /h
Livello sonoro min-max Noise level min-max	46 - 62 db(A)
Assorbimento totale Total absorption	121 W

Filtro grassi alluminio incluso Grease aluminium filter included

ACCESSORI ACCESSORIES	
Filtro carbone Charcoal filter	CFC0141571

MODELLI MODELS	
ELITE 14 LUX GRIX/A/60	PRF0037989B
ELITE 14 LUX GRIX/A/90	PRF0037992B



KREA

ELICA DESIGN CENTER

60 - 90 cm
 Filtrante Filtering
 Acciaio inox, nero, bianco
 Stainless steel, black, white



ENERGY CLASS (A+/D)

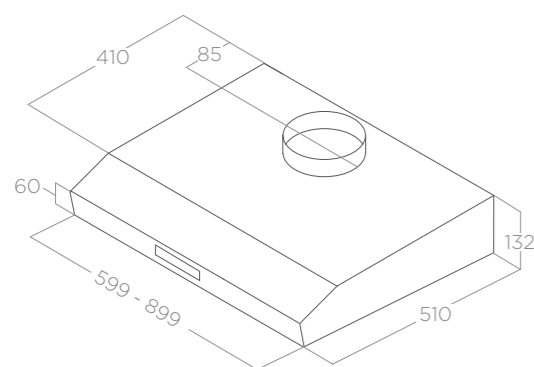

	ILLUMINAZIONE LIGHTING		
Tipo Type	ST	LX	GFA
Intensità Intensity	Led 1x3 W 48 LUX	Led 2x3 W 97 LUX	Led 2x3 W 97 LUX
Temperatura Temperature	2700 K	2700 K	2700 K
	PERFORMANCE PERFORMANCE		
Comandi Controls	Slider meccanico 3V 3S Mechanical slider		
Portata massima Max airflow	ST 265 m³/h	LX 336 m³/h	GFA 265 m³/h
Livello sonoro min-max Noise level min-max	50 - 64 db(A)	52 - 73 db(A)	50 - 64 db(A)
Assorbimento totale Total absorption	98 W	166 W	101 W
Filtro grassi alluminio incluso Grease aluminium Filter included Filtro carbone incluso Charcoal filter included			
	ACCESSORI ACCESSORIES		
Filtro carbone Charcoal filter	CFC0140064		
	MODELLI MODELS		
KREA ST IX F/60	55311065B		
KREA ST IX F/90	55311075B		
KREA LX IX F/60	55311112A		
KREA LX IX F/90	55311129A		
KREA GFA BL/F/60	PRF0104634B		
KREA GFA BL/F/90	PRF0104635B		
KREA GFA WH/F/60	55310774B		
KREA GFA WH/F/90	PRF0104636B		



ESTRAIBILE

ELICA DESIGN CENTER

60 - 90 cm
 Filtrante Filtering
 Silver, Silver + acciaio inox
 Silver, Silver + stainless steel



ENERGY CLASS (A+/D)

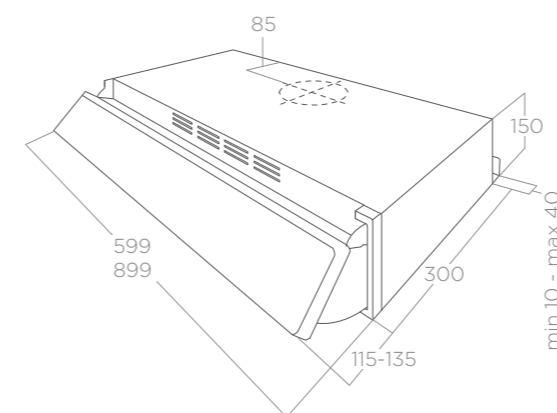

	ILLUMINAZIONE LIGHTING	
Tipo Type	Led 1X2,5 W	Led 2x2,5 W (*)
Intensità Intensity	47 LUX	95 LUX
Temperatura Temperature	2700 K	2700 K
	PERFORMANCE PERFORMANCE	
Comandi Controls	Slider meccanico 3V 3S Mechanical slider	
Portata massima Max airflow	245 m³/h	
Livello sonoro min-max Noise level min-max	45 - 63 db(A)	
Assorbimento totale Total absorption	133 W - 135 (*) W	
Filtro grassi alluminio incluso Grease aluminium Filter included Filtro carbone incluso Charcoal filter included		
	ACCESSORI ACCESSORIES	
Filtro carbone Charcoal filter	CFC0176744	
	MODELLI MODELS	
ESTRAIBILE GR/F/60	PRF0154623A	
ESTRAIBILE GR/F/90	PRF0154626A	
ESTRAIBILE GR-FR.IX/F/60 (*)	PRF0154624A	
ESTRAIBILE GR-FR.IX/F/90 (*)	PRF0154627A	



GOOD TO KNOW

Per te, che sei sempre attento alle nuove tendenze e non ti accontenti dell'estetica, ma vuoi approfondire la funzionalità, abbiamo sviluppato una sezione in cui troverai tutti i dettagli su accessori, informazioni utili, consigli su come scegliere la tua cappa, garanzie e etichetta energetica.

For those of you, who like to keep up with the latest trends and are not just looking for an attractive finish, but also want detailed information about functionality, we have created a section in which you can source all the details on accessories, useful information, advice on how to choose your hood, warranties and energy labels.

RADIOCOMANDI REMOTE CONTROLS

Il radiocomando Elica, disegnato da Fabrizio Crisà, è ultrasottile, resistente e pratico grazie ai magneti che ne consentono il posizionamento su oggetti metallici. In vetro e alluminio. Disponibile nella versione bianca o nera.

The Elica radio control, designed by Fabrizio Crisà, is super thin, resistant and practical, thanks to the magnets that allow it to be placed on metal object. It comes in glass and aluminum, in black or white.

Bianco
White

KIT0121468



Nero
Black

KIT0121469



CONSENTE DI ACCENDERE LA **LUCE AMBIENTE**. CON UNA PRESSIONE PROLUNGATA SI HA LA POSSIBILITÀ DI REGOLARE L'INTENSITÀ DELLA LUCE.

Allows you to turn on the **ambient light**. Hold down for a longer time to adjust the brightness of the light.

BATTERIA RICARICABILE CON PRESA MICRO USB (CAVO IN DOTAZIONE).

Rechargeable battery with micro USB plug. (cord included).

IL TASTO + AUMENTA LA POTENZA DI ASPIRAZIONE MENTRE IL - LA RIDUCE. TENENDO PREMUTO QUEST'ULTIMO LA CAPPA, A PRESCINDERE DALLA VELOCITÀ IN CUI SI TROVA, SI SPEGNE.

The + key increases the aspiration power, while the - key decreases it. By holding down the latter, the hood switches off regardless of its current speed.

LA **LUCE SUL PIANO COTTURA** SI ACCENDE CON UNA LEGGERA PRESSIONE DEL TASTO. CON UNA PRESSIONE PROLUNGATA SI ATTIVANO, A SECONDA DEI MODELLI, LE FUNZIONALITÀ AVANZATE: LA **DIM-LIGHT** (CHE REGOLA L'INTENSITÀ DELLA LUCE) O LA **TUNE-WHITE** (CHE PERMETTE LA VARIAZIONE DELLA TEMPERATURA DEI LED).

The light above the hob is switched on by lightly pressing the key. By holding it down for a longer period, you can activate the advanced features, according to your model: the dim-light (that adjusts brightness) or the tune-white (that allows for the variation of the led light temperature).

FILTRI ODORI ODOUR FILTERS

Filtro carbone Charcoal filter



Il filtro odori tradizionale, composto da una miscela di carboni attivi, perde la sua efficacia attraverso il suo utilizzo ed ha una vita media di 3-6 mesi.

The traditional odour filter, made up of a mix of activated carbons, loses its efficiency through use and has an average life of 3-6 months.

Filtro carbone rigenerabile HP HP Regenerable charcoal filter



Filtro Odori con elevatissimo livello di efficienza >80% capace di rigenerarsi e di durare fino ad un massimo di 3 anni rispetto a filtri standard. Per mantenere tali caratteristiche, il filtro deve essere lavato ogni 2 o 3 mesi con acqua calda e detergente delicato o nella lavastoviglie a 65°C. e poi asciugato in forno per 10 minuti a 100°.

Odour filter with very high efficiency level >80%. Capable of regenerating itself and of lasting up to a maximum of 3 years in comparison to standard filters. To maintain such characteristics, the filter must be washed every 2 or 3 months with hot water and mild soap, or in the dishwasher at 65°C. and can be dried in the oven for 10 minutes at 100°.

Filtro carbone rigenerabile Regenerable charcoal filter



Filtro Odori con livello di efficienza di filtraggio che si aggira tra il 40-60% capace di rigenerarsi e di durare fino ad un massimo di 3 anni rispetto a filtri standard. Per mantenere tali caratteristiche, il filtro deve essere lavato ogni 2 o 3 mesi con acqua calda e detergente delicato o nella lavastoviglie a 65°C. e poi asciugato in forno per 10 minuti a 100°.

Odour filter with filtering efficiency that ranges from 40-60%. Capable of regenerating itself and of lasting up to a maximum of 3 years in comparison to standard filters. To maintain such characteristics, the filter must be washed every 2 or 3 months with hot water and mild soap, or in the dishwasher at 65°C. and can be dried in the oven for 10 minutes at 100°.

Filtro in ceramica anti-odori rigenerabile HP HP regenerable anti-odor ceramic filter



Il filtro ceramico è un filtro carbone modulare che si rigenera termicamente in forno ogni 2/3 mesi a 200° per 45 minuti, fino ad un massimo di 5 anni. Permette di raggiungere un'altissima efficienza di assorbimento odori ed un'elevata resistenza meccanica.

The ceramic filter is a modular charcoal filter that can be thermally regenerated in the oven every 2/3 months at 200° for 45 minutes, up to max 5 years. It allows for very high odour absorption efficiency and very high mechanical strength.

FILTRI ODORI ODOUR FILTERS

	CODICE FILTRO FILTER CODE	TIPO FILTRO FILTER TYPE		CODICE FILTRO FILTER CODE	TIPO FILTRO FILTER TYPE
ACUTA	CFC0140343	Carbone / Charcoal	BOXIN DRY	CFC0140343	Carbone / Charcoal
	CFC0162221	Carbone rigenerabile Regenerable charcoal		CFC0162221	Carbone rigenerabile Regenerable charcoal
ADÉLE	CFC0141529A	Carbone / Charcoal	BOXIN PLUS	CFC0140343	Carbone / Charcoal
	CFC0141725A	Carbone rigenerabile Regenerable charcoal		CFC0162221	Carbone rigenerabile Regenerable charcoal
ADÉLE ISLAND	CFC0141529A	Carbone / Charcoal	BOXIN ADVANCE	CFC0140343	Carbone / Charcoal
	CFC0141725A	Carbone rigenerabile Regenerable charcoal		CFC0162221	Carbone rigenerabile Regenerable charcoal
APLOMB	CFC0140343	Carbone / Charcoal	CIAK 2.0	CFC0141571	Carbone / Charcoal
	CFC0162221	Carbone rigenerabile Regenerable charcoal	CIAK 2.0 S	CFC0141571	Carbone / Charcoal
BELT	CFC0140343	Carbone / Charcoal	CIRCUS	CFC0141529A	Carbone / Charcoal
	CFC0162221	Carbone rigenerabile Regenerable charcoal		CFC0141725A	Carbone rigenerabile Regenerable charcoal
BIO	CFC0140091	Carbone rigenerabile HP Regenerable charcoal HP	CRUISE	CFC0141529A	Carbone / Charcoal
	CFC0141725A	Carbone rigenerabile Regenerable charcoal		CFC0141725A	Carbone rigenerabile Regenerable charcoal
BIO ISLAND	CFC0140091	Carbone rigenerabile HP Regenerable charcoal HP	EASY UX	CFC0140088	Carbone rigenerabile Regenerable charcoal
	CFC0141725A	Carbone rigenerabile Regenerable charcoal	EDITH	CFC0140053	Carbone rigenerabile HP Regenerable charcoal HP
BLOOM	CFC0140343	Carbone / Charcoal		CFC0140090	Carbone rigenerabile Regenerable charcoal
	CFC0162221	Carbone rigenerabile Regenerable charcoal	ELITE 14	CFC0141571	Carbone / Charcoal
BLOOM-S	CFC0140343	Carbone / Charcoal	ELITE 35	CFC0140075	Carbone / Charcoal
	CFC0162221	Carbone rigenerabile Regenerable charcoal	ELLE	CFC0140343	Carbone / Charcoal
BOXIN	CFC0141497	Carbone / Charcoal		CFC0162221	Carbone rigenerabile Regenerable charcoal
BOXIN LX	CFC0140343	Carbone / Charcoal	ERA	CFC0141571	Carbone / Charcoal
	CFC0162221	Carbone rigenerabile Regenerable charcoal	ERA C	CFC0141571	Carbone / Charcoal
BOXIN NO DRIP	CFC0140343	Carbone / Charcoal	ERA S	CFC0141571	Carbone / Charcoal
	CFC0162221	Carbone rigenerabile Regenerable charcoal	ESTRAIBILE	CFC0176744	Carbone / Charcoal

FILTRI ODORI ODOUR FILTERS

	CODICE FILTRO FILTER CODE	TIPO FILTRO FILTER TYPE		CODICE FILTRO FILTER CODE	TIPO FILTRO FILTER TYPE
FLAT GLASS	CFC0141529A	Carbone / Charcoal	HIDDEN ADVANCE	CFC0140343	Carbone / Charcoal
	CFC0141725A	Carbone rigenerabile Regenerable charcoal		CFC0162221	Carbone rigenerabile Regenerable charcoal
FOLD	CFC0140343	Carbone / Charcoal	HYDRA	CFC0140122	Carbone / Charcoal
	CFC0162221	Carbone rigenerabile Regenerable charcoal	IKONA	CFC0140343	Carbone / Charcoal
FOLD S	CFC0140343	Carbone / Charcoal		CFC0162221	Carbone rigenerabile Regenerable charcoal
	GALAXY	CFC0141529A	Carbone / Charcoal	IKONA LIGHT	CFC0140343
CFC0141725A		Carbone rigenerabile Regenerable charcoal	CFC0162221		Carbone rigenerabile Regenerable charcoal
GALAXY ISLAND	CFC0141529A	Carbone / Charcoal	IKONA MAXXI PURE	CFC0162221	Carbone rigenerabile Regenerable charcoal
	CFC0141725A	Carbone rigenerabile Regenerable charcoal	INTERSTELLAR	CFC0140053	Carbone rigenerabile HP Regenerable charcoal HP
GETUP	KIT0166432	Carbone rigenerabile HP Regenerable charcoal HP		CFC0140090	Carbone rigenerabile Regenerable charcoal
	KIT0166444	Carbone rigenerabile Regenerable charcoal	JOY	CFC0141529A	Carbone / Charcoal
GLASS OUT	CFC0140343	Carbone / Charcoal		CFC0141725A	Carbone rigenerabile Regenerable charcoal
	CFC0162221	Carbone rigenerabile Regenerable charcoal	JOY ISLAND	CFC0141529A	Carbone / Charcoal
HAIKU	CFC0141529A	Carbone / Charcoal		CFC0141725A	Carbone rigenerabile Regenerable charcoal
	CFC0141725A	Carbone rigenerabile Regenerable charcoal	JUNO	CFC0140088	Carbone rigenerabile Regenerable charcoal
HAIKU ISLAND	CFC0141529A	Carbone / Charcoal	JUNO URBAN	CFC0140088	Carbone rigenerabile Regenerable charcoal
	CFC0141725A	Carbone rigenerabile Regenerable charcoal	KREA	CFC0140064	Carbone / Charcoal
HIDDEN 2.0	CFC0140343	Carbone / Charcoal	KUADRA ISLAND	CFC0140423	Carbone rigenerabile Regenerable charcoal
	CFC0162221	Carbone rigenerabile Regenerable charcoal	LANE	CFC0140343	Carbone / Charcoal
HIDDEN 2.0 @	CFC0140343	Carbone / Charcoal		CFC0162221	Carbone rigenerabile Regenerable charcoal
	CFC0162221	Carbone rigenerabile Regenerable charcoal	LEVER	CFC0140343	Carbone / Charcoal
		CFC0162221		Carbone rigenerabile Regenerable charcoal	

FILTRI ODORI ODOUR FILTERS

	CODICE FILTRO FILTER CODE	TIPO FILTRO FILTER TYPE		CODICE FILTRO FILTER CODE	TIPO FILTRO FILTER TYPE
LOL	CFC0141529A	Carbone / Charcoal	REEF	CFC0141529A	Carbone / Charcoal
	CFC0141725A	Carbone rigenerabile Regenerable charcoal		CFC0141725A	Carbone rigenerabile Regenerable charcoal
MAJESTIC	CFC0140343	Carbone / Charcoal	REEF ISLAND	CFC0141529A	Carbone / Charcoal
	CFC0162221	Carbone rigenerabile Regenerable charcoal		CFC0141725A	Carbone rigenerabile Regenerable charcoal
MAJESTIC NO DRIP	CFC0140343	Carbone / Charcoal	RUBINO CORNER	CFC0140124	Carbone / Charcoal
	CFC0162221	Carbone rigenerabile Regenerable charcoal	RULES	CFC0166361	Carbone rigenerabile Regenerable charcoal
METEORITE	CFC0141725A	Carbone rigenerabile Regenerable charcoal	SEASHELL	CFC0141725A	Carbone rigenerabile Regenerable charcoal
	CFC0140091	Carbone rigenerabile HP Regenerable charcoal HP	SHEEN-S	CFC0140343	Carbone / Charcoal
METEORITE ISLAND	CFC0141725A	Carbone rigenerabile Regenerable charcoal		CFC0162221	Carbone rigenerabile Regenerable charcoal
	CFC0140091	Carbone rigenerabile HP Regenerable charcoal HP	SHINING	CFC0140053	Carbone rigenerabile HP Regenerable charcoal HP
MISSY	CFC0141497	Carbone / Charcoal		CFC0140090	Carbone rigenerabile Regenerable charcoal
MOON ISLAND	CFC0141529A	Carbone / Charcoal	SHIRE	CFC0140343	Carbone / Charcoal
	CFC0141725A	Carbone rigenerabile Regenerable charcoal		CFC0162221	Carbone rigenerabile Regenerable charcoal
NUAGE	CFC0140343	Carbone / Charcoal	SHY-S	CFC0140343	Carbone / Charcoal
	CFC0162221	Carbone rigenerabile Regenerable charcoal		CFC0162221	Carbone rigenerabile Regenerable charcoal
OPEN SUITE	KIT0166765	Carbone rigenerabile Regenerable charcoal	SPOT NG	CFC0141529A	Carbone / Charcoal
OPEN SUITE SUPERIOR	KIT0166765	Carbone rigenerabile Regenerable charcoal		CFC0141725A	Carbone rigenerabile Regenerable charcoal
OM AIR	CFC0140343	Carbone / Charcoal	SPOT PLUS	CFC0141529A	Carbone / Charcoal
	CFC0162221	Carbone rigenerabile Regenerable charcoal		CFC0141725A	Carbone rigenerabile Regenerable charcoal
PANDORA	CFC0142324	Carbone / Charcoal	SPOT PLUS ISLAND	CFC0141529A	Carbone / Charcoal
PIX	KIT0147175	Carbone rigenerabile Regenerable charcoal		CFC0141725A	Carbone rigenerabile Regenerable charcoal
PLAT	CFC0140423	Carbone rigenerabile Regenerable charcoal	SPOT URBAN	CFC0141529A	Carbone / Charcoal
				CFC0141725A	Carbone rigenerabile Regenerable charcoal

FILTRI ODORI ODOUR FILTERS

	CODICE FILTRO FILTER CODE	TIPO FILTRO FILTER TYPE		CODICE FILTRO FILTER CODE	TIPO FILTRO FILTER TYPE
STONE	CFC0141529A	Carbone / Charcoal	VEGA	CFC0140064	Carbone / Charcoal
	CFC0141725A	Carbone rigenerabile Regenerable charcoal	VERTIGO	CFC0140343	Carbone / Charcoal
STRIPE	CFC0140343	Carbone / Charcoal			CFC0162221
		CFC0162221	Carbone rigenerabile Regenerable charcoal	WAVE UX	CFC0140088
STRIPE URBAN	CFC0140343	Carbone / Charcoal	YE	CFC0141737	Carbone rigenerabile Regenerable charcoal
	CFC0162221	Carbone rigenerabile Regenerable charcoal	ZENITH	CFC0141529A	Carbone / Charcoal
SUPER PLAT	CFC0140423	Carbone rigenerabile Regenerable charcoal			CFC0141725A
SWEET	CFC0140426	Carbone rigenerabile Regenerable charcoal		CODICE FILTRO FILTER CODE	TIPO FILTRO FILTER TYPE
SYNTHESIS	CFC0141529A	Carbone / Charcoal	NT ALPHA	KIT0167755	Filtro in ceramica anti-odori rigenerabile HP HP regenerable anti-odor ceramic filter
	CFC0141725A	Carbone rigenerabile Regenerable charcoal	NIKOLATESLA FIT	KIT0167755	Filtro in ceramica anti-odori rigenerabile HP HP regenerable anti-odor ceramic filter
TAMAYA 2.0	CFC0140343	Carbone / Charcoal	NIKOLATESLA FIT 3Z	KIT0167755	Filtro in ceramica anti-odori rigenerabile HP HP regenerable anti-odor ceramic filter
	CFC0162221	Carbone rigenerabile Regenerable charcoal	NIKOLATESLA FIT XL	KIT0167755	Filtro in ceramica anti-odori rigenerabile HP HP regenerable anti-odor ceramic filter
THIN	CFC0141529A	Carbone / Charcoal	NIKOLATESLA FLAME	KIT0120952A	Filtro in ceramica anti-odori rigenerabile HP HP regenerable anti-odor ceramic filter
	CFC0141725A	Carbone rigenerabile Regenerable charcoal	NIKOLATESLA LIBRA	KIT0120952A	Filtro in ceramica anti-odori rigenerabile HP HP regenerable anti-odor ceramic filter
THIN ISLAND	CFC0141529A	Carbone / Charcoal	NIKOLATESLA ONE	KIT0120952A	Filtro in ceramica anti-odori rigenerabile HP HP regenerable anti-odor ceramic filter
	CFC0141725A	Carbone rigenerabile Regenerable charcoal	NIKOLATESLA ONE HP	KIT0120952A	Filtro in ceramica anti-odori rigenerabile HP HP regenerable anti-odor ceramic filter
TONDA	CFC0140124	Carbone / Charcoal	NIKOLATESLA PRIME S	KIT0167755	Filtro in ceramica anti-odori rigenerabile HP HP regenerable anti-odor ceramic filter
TRIBE	CFC0141529A	Carbone / Charcoal	NIKOLATESLA SWITCH GLOW	KIT0120952A	Filtro in ceramica anti-odori rigenerabile HP HP regenerable anti-odor ceramic filter
	CFC0141725A	Carbone rigenerabile Regenerable charcoal	NIKOLATESLA SWITCH	KIT0120952A	Filtro in ceramica anti-odori rigenerabile HP HP regenerable anti-odor ceramic filter
TRIBE ISLAND	CFC0141529A	Carbone / Charcoal	NIKOLATESLA UNPLUGGED	KIT0120952A	Filtro in ceramica anti-odori rigenerabile HP HP regenerable anti-odor ceramic filter
	CFC0141725A	Carbone rigenerabile Regenerable charcoal			
TUBE PRO	CFC0140423	Carbone rigenerabile Regenerable charcoal			
TUBE PRO ISLAND	CFC0140423	Carbone rigenerabile Regenerable charcoal			

* per i kit filtro carbone relativi ai modelli ceiling vedere nella sezione dedicata

* see the dedicated section for the ceiling model carbon filter kits

MOTORI REMOTI CAPPE CEILING CEILING HOOD REMOTE MOTORS

La scelta di un motore remoto, posizionato a seconda delle esigenze installative, consente un maggiore comfort acustico quando la cappa è in funzione e la cattura di fumi e odori è massimizzata grazie alla maggiore efficienza di aspirazione di questo tipo di motori.

I motori che seguono sono destinati esclusivamente all'installazione sulle cappe ceiling predisposte. È possibile scegliere tra 4 tipologie di motori differenti a seconda delle esigenze di installazione.

The choice of a remote motor, positioned according to installation needs, allows for lower noise levels when the hood is in operation, and fume and odor capture is optimized, thanks to the improved extraction efficiency of this type of motor.

The following motors are intended exclusively for installation on compatible ceiling hoods. It is possible to choose between 4 different types of motors based on installation needs.

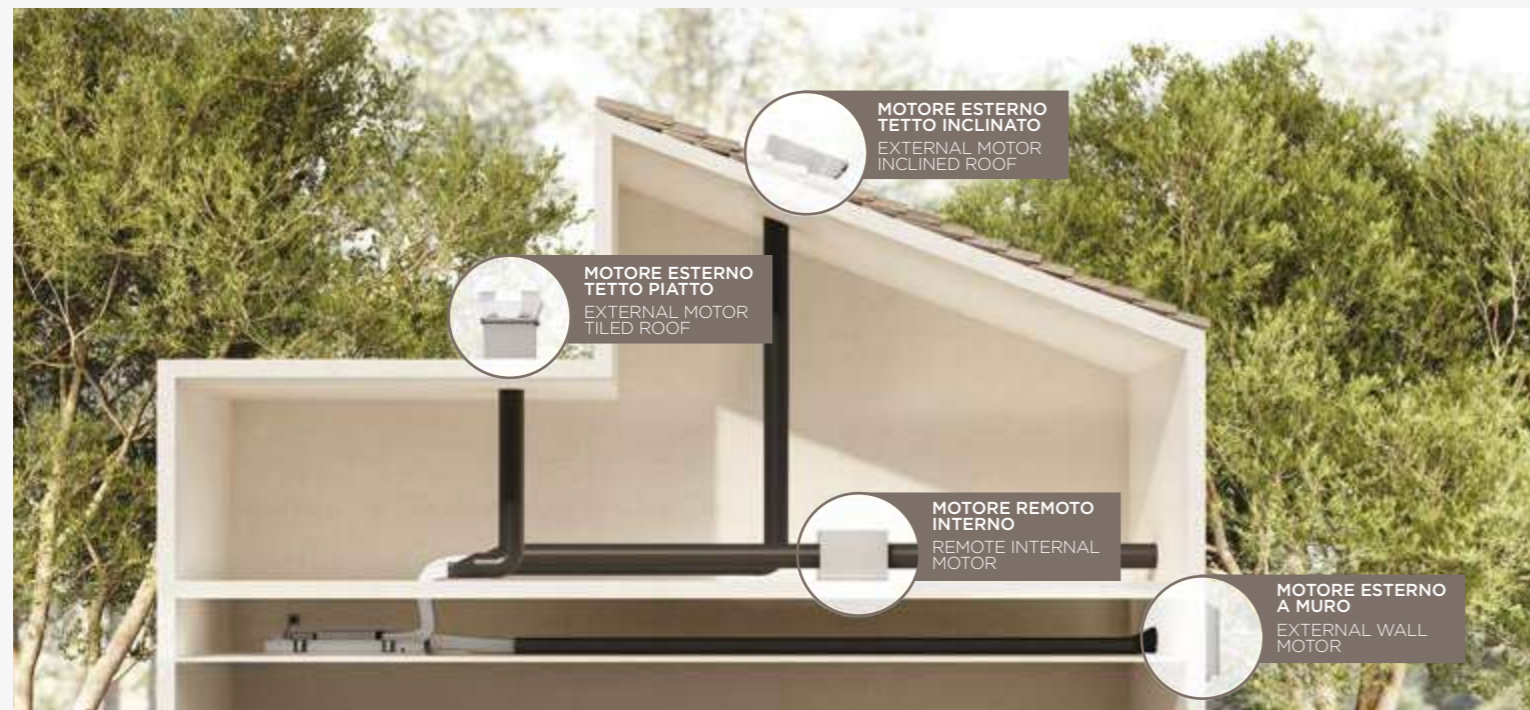

KIT0184296 MOTORE REMOTO INTERNO REMOTE INTERNAL MOTOR



H CONTROSOFFITTO H False ceiling	> 30cm
Uscita Exit	Ø 15cm rotonda Ø 15cm round
Distanza cappa-uscita Hood-exit distance	max 7 mt lineari* max 7 linear mt*
+ cavo di proluga KIT0161392 + extension cable KIT0161392	

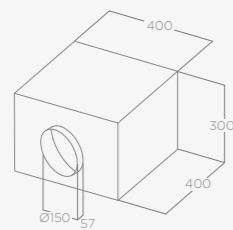

Portata Airflow	2150 m ³ /h
Assorbimento totale Total absorption	250 W
Uscita Exit	150 mm

Disponibile per Available for
HILIGHT GLASS / HILIGHT-X
ILLUSION / SKYDOME

* Senza curve. Togliere 1 mt per ogni curva.
* Without bends. Deduct 1 mt. for each bend.

KIT0184135 GME MOTORE ESTERNO A MURO GME EXTERNAL WALL MOTOR



H CONTROSOFFITTO H False ceiling	> 16,2cm
Uscita Exit	Ø 15cm rotonda Ø 15cm round
Distanza cappa-uscita Hood-exit distance	max 7 mt lineari* max 7 linear mt*
+ cavo di proluga KIT0161392 + extension cable KIT0161392	

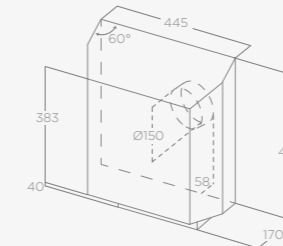

Portata Airflow	1300 m ³ /h
Assorbimento totale Total absorption	275 W
Uscita Exit	150 mm

Disponibile per Available for
HILIGHT GLASS / HILIGHT-X
ILLUSION / SKYDOME

* Senza curve. Togliere 1 mt per ogni curva.
* Without bends. Deduct 1 mt. for each bend.

KIT0147882 GME MOTORE ESTERNO TETTO INCLINATO GME EXTERNAL INCLINED ROOF



H CONTROSOFFITTO H False ceiling	> 16,2cm
Uscita Exit	Ø 15cm rotonda Ø 15cm round
Distanza cappa-uscita Hood-exit distance	max 7 mt lineari* max 7 linear mt*
+ cavo di proluga KIT0161392 + extension cable KIT0161392	

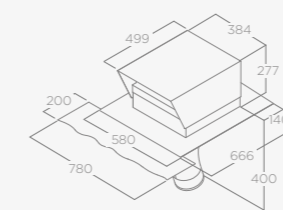

Portata Airflow	1200 m ³ /h
Assorbimento totale Total absorption	200 W
Uscita Exit	150 mm

Disponibile per Available for
HILIGHT GLASS / HILIGHT-X
ILLUSION / SKYDOME

* Senza curve. Togliere 1 mt per ogni curva.
* Without bends. Deduct 1 mt. for each bend.

KIT0147881 GME MOTORE ESTERNO TETTO PIATTO GME EXTERNAL TILED ROOF



H CONTROSOFFITTO H False ceiling	> 16,2cm
Uscita Exit	Ø 15cm rotonda Ø 15cm round
Distanza cappa-uscita Hood-exit distance	max 7 mt lineari* max 7 linear mt*
+ cavo di proluga KIT0161392 + extension cable KIT0161392	

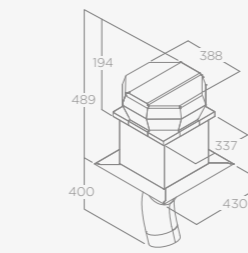

Portata Airflow	1200 m ³ /h
Assorbimento totale Total absorption	200 W
Uscita Exit	150 mm

Disponibile per Available for
HILIGHT GLASS / HILIGHT-X
ILLUSION / SKYDOME

* Senza curve. Togliere 1 mt per ogni curva.
* Without bends. Deduct 1 mt. for each bend.

MOTORI REMOTI REMOTE MOTORS

I motori che seguono possono essere installati esclusivamente sui nostri modelli tradizionali e Downdraft già predisposti a questo scopo.

The following motors can only be installed on our traditional and Downdraft models already predisposed for this purpose.

Downdraft Downdraft



MOTORE ESTERNO A MURO
EXTERNAL WALL MOTOR

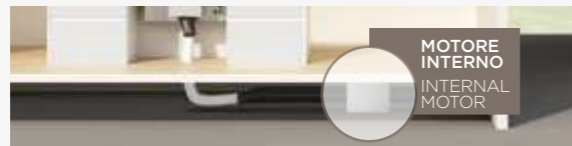

MOTORE INTERNO
INTERNAL MOTOR

Cappa tradizionale Traditional hood



MOTORE ESTERNO A MURO
EXTERNAL WALL MOTOR



MOTORE INTERNO
INTERNAL MOTOR

PRF0179706 GME22A MOTORE ESTERNO A MURO GME22A EXTERNAL WALL MOTOR



Uscita Exit	Ø 15cm rotonda Ø 15cm round
Distanza cappa-uscita Hood-exit distance	max 5 mt lineari* max 5 linear mt*

+ cavo di proluga KIT0161392
+ extension cable KIT0161392

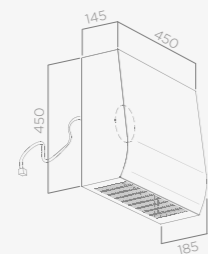

Portata Airflow	1200 m ³ /h
Assorbimento totale Total absorption	190 W
Uscita Exit	150 mm

Disponibile per Available for
CT35 PRO / PANDORA

* Senza curve. Togliere 1 mt per ogni curva.
* Without bends. Deduct 1 mt. for each bend.

PRF0046491A GME88 MOTORE REMOTO INTERNO GME88 REMOTE INTERNAL MOTOR
PRF006209A GME11 MOTORE REMOTO INTERNO GME11 REMOTE INTERNAL MOT

Uscita Exit	Ø 15cm rotonda Ø 15cm round
Distanza cappa-uscita Hood-exit distance	max 5 mt lineari* max 5 linear mt*

+ cavo di proluga KIT0161392
+ extension cable KIT0161392

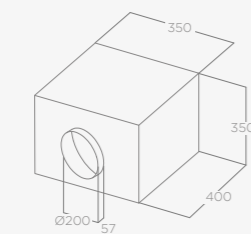
PRF0046491A
GME88 MOTORE REMOTO INTERNO
GME88 REMOTE INTERNAL MOTOR

Portata Airflow	1495 m ³ /h
Assorbimento totale Total absorption	250 W(50Hz) 390 W(60Hz)
Uscita Exit	150 mm

Disponibile per Available for
PANDORA

PRF006209A
GME11 MOTORE REMOTO INTERNO
GME11 REMOTE INTERNAL MOTOR

Portata Airflow	1000 m ³ /h
Assorbimento totale Total absorption	275 W
Uscita Exit	150 mm

Disponibile per Available for
CT35 PRO

* Senza curve. Togliere 1 mt per ogni curva.
* Without bends. Deduct 1 mt. for each bend.

FILTRI GRASSI
GREASE FILTERSFiltro Grassi Alluminio
Aluminium Grease Filter
KIT0010805

Disponibile per Available for
ACUTA / ADÉLE / ADÉLE ISLAND / BLOOM / BLOOM-S
CRUISE / HYDRA / JOY JOY ISLAND / LOL
MAJESTIC / MISSY / RUBINO CORNER / SPOT NG / SPOT PLUS / SPOT PLUS ISLAND
SPOT URBAN / STRIPE STRIPE URBAN / TAMAYA 2.0

Filtro grassi a strati in alluminio (GFA). Questo filtro è il più diffuso sul mercato anche perché grazie alla sua dimensione può essere facilmente lavato a mano e in lavastoviglie.

Layered aluminum grease filter (GFA). This filter is the most common on the market, also because, thanks to its size it can be easily washed by hand, or in the dishwasher.

Filtro Professionale Buffle
Buffle Professional Filter
KIT0010804

Disponibile per Available for
ADÉLE / ADÉLE ISLAND JOY / MISSY / SPOT PLUS SPOT PLUS ISLAND

Filtro grassi completamente in acciaio che dà al prodotto un aspetto tipico delle cappe industriali. Grazie al labirinto degli strati in acciaio, questo filtro ha un'elevata captazione dei grassi.

All steel grease filter that gives the product a typical industrial hood look. Thanks to the labyrinth of steel layers, this filter has a high grease capturing capacity.

Filtri Grassi Professionali Inox
Professional Stainless Steel Grease Filters
KIT0010806

Disponibile per Available for
ACUTA / ADÉLE / ADÉLE ISLAND / CRUISE / HYDRA JOY / JOY ISLAND / LOL
MAJESTIC NO DRIP MISSY / RUBINO CORNER
SPOT NG / SPOT PLUS SPOT PLUS ISLAND / SPOT URBAN / TAMAYA 2.0

Filtro grassi con primo strato in acciaio e lamiera microforata posteriore, facilmente lavabile e con un'elevata captazione dei grassi.

Grease filter with the first layer in steel and a microperforated back metal sheet, easily washable and with high grease capturing capacity.

KIT CAMINO ACCIAIO INOX
STAINLESS STEEL CHIMNEY KIT

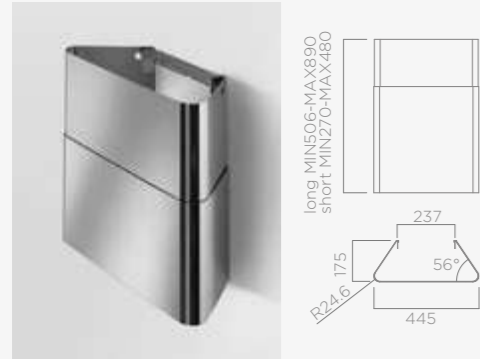

Long KIT0010439 Short KIT0010700
Disponibile per Available for
OM AIR

KIT CAMINO ACCIAIO INOX
STAINLESS STEEL CHIMNEY KIT

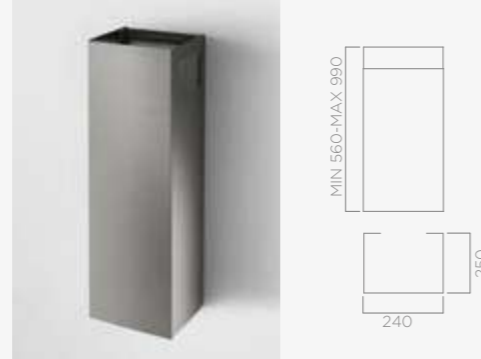

KIT0177845
Disponibile per Available for
BELT / ELLE / VERTIGO

KIT CAMINO ACCIAIO INOX H12
STAINLESS STEEL CHIMNEY KIT H12



KIT0091876
Disponibile per Available for
BOXIN / BOXIN ADVANCE / BOXIN DRY / BOXIN NO
DRIP / BOXIN PLUS / GLASS OUT / LEVER

KIT CAMINO ACCIAIO INOX H185+H185
STAINLESS STEEL CHIMNEY KIT H185+H185

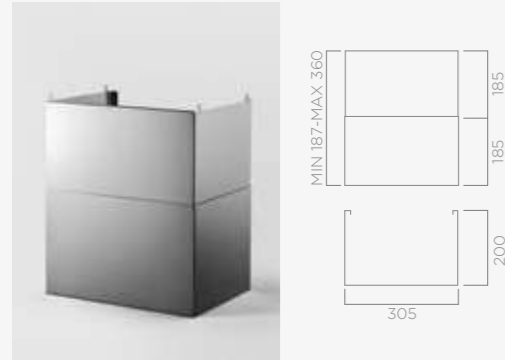

KIT0141458
Disponibile per Available for
BOXIN / BOXIN ADVANCE / BOXIN DRY /
BOXIN NO DRIP / BOXIN PLUS / GLASS OUT /
HIDDEN 2.0 / HIDDEN 2.0@ /
HIDDEN ADVANCE / LEVER

KIT CAMINO NERO
BLACK CHIMNEY KIT

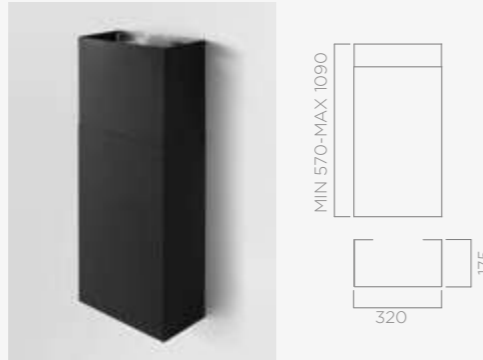

KIT0166364
Disponibile per Available for
PLAT / RULES / SUPER PLAT

KIT CAMINO ACCIAIO INOX
STAINLESS STEEL CHIMNEY KIT



KIT0171543
Disponibile per Available for
PLAT / RULES / SUPER PLAT

KIT CAMINO NERO
BLACK CHIMNEY KIT



KIT0175017
Disponibile per Available for
IKONA MAXXI PURE

KIT CAMINO ACCIAIO INOX
STAINLESS STEEL CHIMNEY KIT



KIT0175018
Disponibile per Available for
IKONA MAXXI PURE

	NO RETURN VALVE
KIT01513 / KIT01797	---
KIT0010439 / KIT0010700	✓
KIT0177845	✓
KIT0010703 / KIT0010704	✓
KIT0091876	---
KIT0141458	---
KIT0166364	✓
KIT0171543	✓

KIT MENSOLA SHELF KIT

LULLABY



KIT0147858

KIT MENSOLA LULLABY
(LEGNO)
SHELF KIT LULLABY
(WOODEN)

KIT0147859

KIT MENSOLA LULLABY
(BIANCO)
SHELF KIT LULLABY
(WHITE)

BIO



KIT MENSOLA BIO 60CM
SHELF KIT BIO 60CM

KIT0120946

BIO ISLAND

KIT0120947

KIT MENSOLA BIO ISLAND
60CM + 2 CAVI
SHELF KIT BIO ISLAND 60CM
+ 2 CABLES

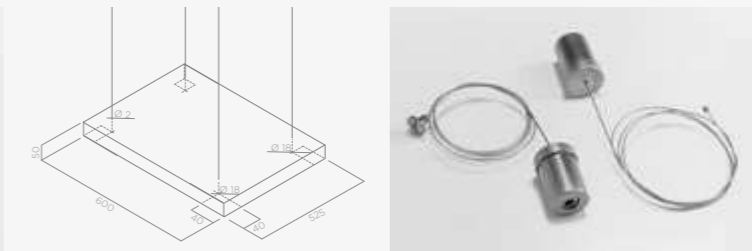

KIT CAVI BIO ISLAND 1,7 MT
KIT CABLES BIO ISLAND 1,7 MT

KIT0120948

ACCESSORI DI INSTALLAZIONE INSTALLATION ACCESSORIES



150x70x1500mm
1052B



150x70x1000mm
1052C



90° 150x70mm
1052F



150x70 - Ø125mm
1052G



Ø125-100mm
1052L



Ø125x1000mm
1052N



Ø125x3000mm
1052W



Ø125x1000mm
1052O



Ø125
1052P



150x70 - Ø125mm
1052Q



90° Ø125mm
1052R



150x70mm
1052D



90° 150x70mm
1052E



Ø125x750mm + fascette
KIT0094727



Ø150x240 mm
KIT0161457

Per evitare la creazione di condensa e il ritorno della stessa verso la fonte di espulsione dell'aria, consigliamo di installare questo componente lungo la condotta di uscita.

To avoid the formation of condensate and the flowback towards the source of air output, we advise installing this component along the outlet pipe.

ACCESSORI DI INSTALLAZIONE INSTALLATION ACCESSORIES



220x90x1000mm
1053M



Ø150x500mm
1053X



150x70 - Ø150mm
1053Q



90° 220x90mm
1053S



Ø150-120mm
1052M



Ø150x3000mm
1052AD



Ø150x1000mm
1053W



Ø150
1053Z



220x90 - Ø150mm
1053P



220x90mm
1053N



Ø150mm
1053Y



90° 220x90mm
1053R



Ø150x750mm + fascette
KIT0094725



Ø150
KIT0162617

DIFFUSORE ARIA DA PENSILE PER PRODOTTI FILTRANTI BUILT-IN.
WALL UNIT AIR DIFFUSER FOR BUILT-IN FILTER PRODUCTS.

Utile per evitare l'intrusione di oggetti nel condotto d'aria e per direzionare il flusso di vapore in uscita verso il centro della stanza.

Useful for stopping objects getting into the air duct and to channel the vapour flow emitted towards the centre of the room.

APPROFONDIMENTI PERFORMANCE

LEARN MORE ABOUT PERFORMANCE

	ENERGY CLASS	1 SPEED (airflow-noise)	2 SPEED (airflow-noise)	3 SPEED (airflow-noise)	4 SPEED * (airflow-noise)	5 SPEED * (airflow-noise)
Acuta	A	272 m³/h - 46 db(A)	368 m³/h - 53 db(A)	515 m³/h - 60 db(A)	---	625 m³/h - 65 db(A)
Adèle	A	325 m³/h - 55 db(A)	435 m³/h - 61 db(A)	630 m³/h - 69 db(A)	---	770 m³/h - 74 db(A)
Adèle Island	A	325 m³/h - 55 db(A)	435 m³/h - 61 db(A)	630 m³/h - 69 db(A)	---	770 m³/h - 74 db(A)
Aplomb	A	275 m³/h - 51 db(A)	385 m³/h - 59 db(A)	495 m³/h - 64 db(A)	---	680 m³/h - 71 db(A)
Belt	A	250 m³/h - 46 db(A)	350 m³/h - 54 db(A)	475 m³/h - 61 db(A)	---	590 m³/h - 65 db(A)
Bio	A	135 m³/h - 35 db(A)	300 m³/h - 53 db(A)	395 m³/h - 58 db(A)	545 m³/h - 65 db(A)	720 m³/h - 70 db(A)
Bio Island	A	135 m³/h - 35 db(A)	300 m³/h - 53 db(A)	395 m³/h - 58 db(A)	545 m³/h - 65 db(A)	720 m³/h - 70 db(A)
Bloom	A	185 m³/h - 35 db(A)	310 m³/h - 52 db(A)	400 m³/h - 56 db(A)	---	750 m³/h - 70 db(A)
Bloom-S	A	185 m³/h - 35 db(A)	310 m³/h - 46 db(A)	400 m³/h - 53 db(A)	590 m³/h - 58 db(A)	750 m³/h - 64 db(A)
Boxin	D	140 m³/h - 48 db(A)	190 m³/h - 54 db(A)	370 m³/h - 67 db(A)	---	---
Boxin Advance	A	305 m³/h - 50 db(A)	415 m³/h - 57 db(A)	560 m³/h - 64 db(A)	---	730 m³/h - 70 db(A)
Boxin Dry	B	270 m³/h - 52 db(A)	400 m³/h - 60 db(A)	580 m³/h - 67 db(A)	---	700 m³/h - 71 db(A)
Boxin Lux	A	255 m³/h - 50 db(A)	355 m³/h - 57 db(A)	620 m³/h - 70 db(A)	---	---
Boxin No Drip	A	160 m³/h - 34 db(A)	425 m³/h - 60 db(A)	570 m³/h - 66 db(A)	---	680 m³/h - 70 db(A)
Boxin Plus	B	230 m³/h - 49 db(A)	335 m³/h - 56 db(A)	610 m³/h - 70 db(A)	---	---
Ciak 2.0	C	130 m³/h - 47 db(A)	165 m³/h - 50 db(A)	225 m³/h - 55 db(A)	---	---
Ciak 2.0 S	B	250 m³/h - 57 db(A)	340 m³/h - 64 db(A)	425 m³/h - 69 db(A)	---	---
Circus	D	195 m³/h - 55 db(A)	368 m³/h - 56 db(A)	384 m³/h - 62 db(A)	---	---
Cloud Seven (Duct-out)	A	235 m³/h - 43 db(A)	330 m³/h - 54 db(A)	460 m³/h - 60 db(A)	660 m³/h - 68 db(A)	770 m³/h - 71 db(A)
Cloud Seven (Filtering)	A	240 m³/h - 52 db(A)	360 m³/h - 62 db(A)	495 m³/h - 68 db(A)	570 m³/h - 70 db(A)	---
Cruise	B	288 m³/h - 51 db(A)	432 m³/h - 61 db(A)	581 m³/h - 69 db(A)	---	713 m³/h - 73 db(A)
CT35 PRO 60 cm	B	225 m³/h - 51 db(A)	430 m³/h - 64 db(A)	600 m³/h - 73 db(A)	---	650 m³/h - 75 db(A)
CT35 PRO 90 cm	A	255 m³/h - 50 db(A)	420 m³/h - 60 db(A)	650 m³/h - 69 db(A)	---	750 m³/h - 73 db(A)
CT35 PRO 120 cm	A	265 m³/h - 52 db(A)	430 m³/h - 60 db(A)	650 m³/h - 69 db(A)	---	780 m³/h - 74 db(A)
CT35 PRO GME	B	215 m³/h - 41 db(A)	405 m³/h - 59 db(A)	550 m³/h - 67 db(A)	---	610 m³/h - 70 db(A)
Easy UX	A	265 m³/h - 46 db(A)	365 m³/h - 55 db(A)	515 m³/h - 62 db(A)	---	610 m³/h - 66 db(A)
Edith	A	240 m³/h - 46 db(A)	300 m³/h - 49 db(A)	345 m³/h - 53 db(A)	460 m³/h - 59 db(A)	---
Elite 14	D	125 m³/h - 46 db(A)	288 m³/h - 57 db(A)	304 m³/h - 62 db(A)	---	---
Elite 35	A	250 m³/h - 46 db(A)	375 m³/h - 55 db(A)	535 m³/h - 63 db(A)	---	640 m³/h - 67 db(A)
Elle	A	310 m³/h - 52 db(A)	420 m³/h - 59 db(A)	570 m³/h - 65 db(A)	750 m³/h - 71 db(A)	---
Era	C	125 m³/h - 45 db(A)	155 m³/h - 47 db(A)	224 m³/h - 54 db(A)	---	---
Era C	D	290 m³/h - 62 db(A)	344 m³/h - 66 db(A)	368 m³/h - 67 db(A)	---	---
Era S	B	236 m³/h - 57 db(A)	332 m³/h - 63 db(A)	428 m³/h - 68 db(A)	---	---
Estrabile	D	105 m³/h - 45 db(A)	135 m³/h - 51 db(A)	245 m³/h - 63 db(A)	---	---

* Velocità intensive temporizzate *Booster time speeds

** Modello non soggetto a certificazione energetica obbligatoria *Model not subject to compulsory energy certification.

APPROFONDIMENTI PERFORMANCE

LEARN MORE ABOUT PERFORMANCE

	ENERGY CLASS	1 SPEED (airflow-noise)	2 SPEED (airflow-noise)	3 SPEED (airflow-noise)	4 SPEED * (airflow-noise)	5 SPEED * (airflow-noise)
Flat Glass	D	195 m³/h - 55 db(A)	368 m³/h - 56 db(A)	384 m³/h - 62 db(A)	---	---
Fold	B	225 m³/h - 46 db(A)	355 m³/h - 54 db(A)	580 m³/h - 65 db(A)	---	---
Fold S	B	300 m³/h - 53 db(A)	440 m³/h - 60 db(A)	600 m³/h - 66 db(A)	---	710 m³/h - 70 db(A)
Galaxy	C	288 m³/h - 52 db(A)	416 m³/h - 61 db(A)	559 m³/h - 69 db(A)	---	647 m³/h - 73 db(A)
Galaxy Island	C	288 m³/h - 52 db(A)	416 m³/h - 61 db(A)	559 m³/h - 69 db(A)	---	647 m³/h - 73 db(A)
Getup	A	230 m³/h - 43 db(A)	360 m³/h - 54 db(A)	540 m³/h - 63 db(A)	650 m³/h - 66 db(A)	730 m³/h - 68 db(A)
Glass Out	A	235 m³/h - 53 db(A)	315 m³/h - 54 db(A)	425 m³/h - 61 db(A)	---	560 m³/h - 65 db(A)
Haiku	A	155 m³/h - 34 db(A)	295 m³/h - 47 db(A)	375 m³/h - 51 db(A)	560 m³/h - 58 db(A)	690 m³/h - 63 db(A)
Haiku Island	A	155 m³/h - 34 db(A)	295 m³/h - 47 db(A)	375 m³/h - 51 db(A)	560 m³/h - 58 db(A)	690 m³/h - 63 db(A)
Hidden 2.0	A	300 m³/h - 51 db(A)	420 m³/h - 60 db(A)	600 m³/h - 67 db(A)	---	700 m³/h - 70 db(A)
Hidden 2.0 @	A	300 m³/h - 51 db(A)	420 m³/h - 60 db(A)	600 m³/h - 67 db(A)	---	700 m³/h - 70 db(A)
Hidden 2.0 Advance	A	300 m³/h - 51 db(A)	420 m³/h - 60 db(A)	600 m³/h - 67 db(A)	---	690 m³/h - 70 db(A)
Hilight Glass H16	A	275 m³/h - 51 db(A)	425 m³/h - 62 db(A)	540 m³/h - 68 db(A)	660 m³/h - 72 db(A)	720 m³/h - 74 db(A)
Hilight Glass H30	A	200 m³/h - 40 db(A)	380 m³/h - 50 db(A)	465 m³/h - 53 db(A)	690 m³/h - 63 db(A)	770 m³/h - 66 db(A)
Hilight-X H16	A+	275 m³/h - 51 db(A)	425 m³/h - 62 db(A)	540 m³/h - 68 db(A)	660 m³/h - 72 db(A)	720 m³/h - 74 db(A)
Hilight-X H30	A	200 m³/h - 42 db(A)	380 m³/h - 55 db(A)	475 m³/h - 62 db(A)	690 m³/h - 67 db(A)	770 m³/h - 70 db(A)
Hydra	C	195 m³/h - 46 db(A)	256 m³/h - 63 db(A)	496 m³/h - 68 db(A)	---	---
Ikona	A	250 m³/h - 47 db(A)	355 m³/h - 55 db(A)	475 m³/h - 62 db(A)	---	610 m³/h - 67 db(A)
Ikona Light	A	250 m³/h - 47 db(A)	355 m³/h - 55 db(A)	475 m³/h - 62 db(A)	---	610 m³/h - 67 db(A)
Ikona Maxxi Pure	A	245 m³/h - 47 db(A)	360 m³/h - 56 db(A)	485 m³/h - 62 db(A)	---	600 m³/h - 67 db(A)
Illusion H16	A	275 m³/h - 51 db(A)	425 m³/h - 62 db(A)	540 m³/h - 68 db(A)	660 m³/h - 72 db(A)	720 m³/h - 74 db(A)
Illusion H30	A	200 m³/h - 40 db(A)	380 m³/h - 50 db(A)	465 m³/h - 53 db(A)	690 m³/h - 63 db(A)	770 m³/h - 66 db(A)
Interstellar	A	165 m³/h - 36 db(A)	209 m³/h - 53 db(A)	336 m³/h - 54 db(A)	---	384 m³/h - 56 db(A)
Joy	B	288 m³/h - 51 db(A)	432 m³/h - 61 db(A)	581 m³/h - 69 db(A)	---	713 m³/h - 73 db(A)
Joy Island	B	288 m³/h - 51 db(A)	432 m³/h - 61 db(A)	581 m³/h - 69 db(A)	---	713 m³/h - 73 db(A)
Juno	A	255 m³/h - 45 db(A)	380 m³/h - 55 db(A)	620 m³/h - 67 db(A)	---	---
Juno Urban	A	255 m³/h - 45 db(A)	380 m³/h - 55 db(A)	620 m³/h - 67 db(A)	---	---
Krea GFA / ST	D	125 m³/h - 50 db(A)	165 m³/h - 55 db(A)	265 m³/h - 64 db(A)	---	---
Krea LUX	D	135 m³/h - 52 db(A)	185 m³/h - 61 db(A)	336 m³/h - 73 db(A)	---	---
Kuadra Island	D	224 m³/h - 48 db(A)	320 m³/h - 56 db(A)	416 m³/h - 62 db(A)	---	496 m³/h - 66 db(A)
Lane	B	255 m³/h - 49 db(A)	400 m³/h - 58 db(A)	550 m³/h - 65 db(A)	---	650 m³/h - 68 db(A)
Lever	B	240 m³/h - 46 db(A)	336 m³/h - 54 db(A)	603 m³/h - 67 db(A)	---	---
LoI	A	280 m³/h - 52 db(A)	405 m³/h - 60 db(A)	540 m³/h - 67 db(A)	---	620 m³/h - 70 db(A)

* Velocità intensive temporizzate *Booster time speeds

** Modello non soggetto a certificazione energetica obbligatoria *Model not subject to compulsory energy certification.

APPROFONDIMENTI PERFORMANCE

LEARN MORE ABOUT PERFORMANCE

	ENERGY CLASS	1 SPEED (airflow-noise)	2 SPEED (airflow-noise)	3 SPEED (airflow-noise)	4 SPEED * (airflow-noise)	5 SPEED * (airflow-noise)
Lullaby Duct-out	A	200 m³/h - 40 db(A)	380 m³/h - 50 db(A)	465 m³/h - 53 db(A)	690 m³/h - 63 db(A)	770 m³/h - 66 db(A)
Lullaby Filtering	**	100 m³/h - 44 db(A)	155 m³/h - 53 db(A)	237 m³/h - 63 db(A)	380 m³/h - 72 db(A)	474 m³/h - 76 db(A)
Majestic	B	288 m³/h - 49 db(A)	432 m³/h - 57 db(A)	603 m³/h - 65 db(A)	---	691 m³/h - 68 db(A)
Majestic No Drip	A	245 m³/h - 46 db(A)	345 m³/h - 53 db(A)	485 m³/h - 60 db(A)	---	600 m³/h - 66 db(A)
Meteorite	A	125 m³/h - 32 db(A)	295 m³/h - 49 db(A)	395 m³/h - 56 db(A)	535 m³/h - 62 db(A)	700 m³/h - 68 db(A)
Meteorite Island	A	125 m³/h - 32 db(A)	295 m³/h - 49 db(A)	395 m³/h - 56 db(A)	535 m³/h - 62 db(A)	700 m³/h - 68 db(A)
Missy	D	165 m³/h - 49 db(A)	225 m³/h - 55 db(A)	395 m³/h - 68 db(A)	---	---
Moon Island	D	285 m³/h - 52 db(A)	425 m³/h - 61 db(A)	570 m³/h - 68 db(A)	---	690 m³/h - 72 db(A)
Nuage	A	230 m³/h - 49 db(A)	330 m³/h - 53 db(A)	440 m³/h - 62 db(A)	---	580 m³/h - 65 db(A)
Om Air	A	295 m³/h - 52 db(A)	385 m³/h - 57 db(A)	515 m³/h - 62 db(A)	700 m³/h - 68 db(A)	---
Open Suite	**	335 m³/h - 63 db(A)	395 m³/h - 66 db(A)	445 m³/h - 69 db(A)	---	500 m³/h - 71 db(A)
Open Suite Superior	**	335 m³/h - 63 db(A)	395 m³/h - 66 db(A)	445 m³/h - 69 db(A)	---	500 m³/h - 71 db(A)
Pandora	A	208 m³/h - 45 db(A)	288 m³/h - 49 db(A)	496 m³/h - 59 db(A)	---	669 m³/h - 67 db(A)
Pandora GME	C	240 m³/h - 58 db(A)	336 m³/h - 60 db(A)	581 m³/h - 71 db(A)	---	713 m³/h - 72 db(A)
Pix	A	250 m³/h - 44 db(A)	358 m³/h - 53 db(A)	445 m³/h - 60 db(A)	---	610 m³/h - 65 db(A)
Plat	A	160 m³/h - 37 db(A)	315 m³/h - 50 db(A)	420 m³/h - 57 db(A)	---	710 m³/h - 69 db(A)
Reef	A	255 m³/h - 48 db(A)	365 m³/h - 57 db(A)	500 m³/h - 64 db(A)	---	600 m³/h - 69 db(A)
Reef Island	A	255 m³/h - 48 db(A)	365 m³/h - 57 db(A)	500 m³/h - 64 db(A)	---	600 m³/h - 69 db(A)
Rubino Corner	C	224 m³/h - 42 db(A)	336 m³/h - 51 db(A)	603 m³/h - 64 db(A)	---	---
Rules	A	160 m³/h - 40 db(A)	330 m³/h - 53 db(A)	415 m³/h - 58 db(A)	---	700 m³/h - 71 db(A)
Seashell	**	180 m³/h - 55 db(A)	265 m³/h - 63 db(A)	335 m³/h - 67 db(A)	---	400 m³/h - 70 db(A)
Sheen-S	A	275 m³/h - 52 db(A)	385 m³/h - 59 db(A)	495 m³/h - 65 db(A)	---	650 m³/h - 71 db(A)
Shining	A	240 m³/h - 46 db(A)	300 m³/h - 49 db(A)	345 m³/h - 53 db(A)	460 m³/h - 59 db(A)	---
Shire	A	275 m³/h - 52 db(A)	495 m³/h - 64 db(A)	---	---	650 m³/h - 71 db(A)
Shy-S	A	275 m³/h - 52 db(A)	385 m³/h - 59 db(A)	495 m³/h - 65 db(A)	---	650 m³/h - 71 db(A)
Skydome H16	A	275 m³/h - 51 db(A)	425 m³/h - 62 db(A)	540 m³/h - 68 db(A)	660 m³/h - 72 db(A)	720 m³/h - 74 db(A)
Skydome H30	A	200 m³/h - 40 db(A)	380 m³/h - 50 db(A)	465 m³/h - 53 db(A)	690 m³/h - 63 db(A)	770 m³/h - 66 db(A)
Spot NG	D	195 m³/h - 55 db(A)	224 m³/h - 56 db(A)	368 m³/h - 62 db(A)	---	---
Spot Plus	A	280 m³/h - 52 db(A)	405 m³/h - 60 db(A)	540 m³/h - 67 db(A)	---	620 m³/h - 70 db(A)
Spot Plus Island	A	280 m³/h - 52 db(A)	405 m³/h - 60 db(A)	540 m³/h - 67 db(A)	---	620 m³/h - 70 db(A)
Spot Urban	B	270 m³/h - 52 db(A)	375 m³/h - 59 db(A)	630 m³/h - 71 db(A)	---	---
Stone	C	240 m³/h - 44 db(A)	368 m³/h - 53 db(A)	559 m³/h - 67 db(A)	---	---
Stripe / Stripe Urban	B	304 m³/h - 50 db(A)	432 m³/h - 58 db(A)	603 m³/h - 65 db(A)	---	757 m³/h - 69 db(A)
Super Plat	A	175 m³/h - 37 db(A)	325 m³/h - 50 db(A)	415 m³/h - 57 db(A)	600 m³/h - 65 db(A)	740 m³/h - 70 db(A)

* Velocità intensive temporizzate *Booster time speeds

** Modello non soggetto a certificazione energetica obbligatoria *Model not subject to compulsory energy certification.

APPROFONDIMENTI PERFORMANCE

LEARN MORE ABOUT PERFORMANCE

	ENERGY CLASS	1 SPEED (airflow-noise)	2 SPEED (airflow-noise)	3 SPEED (airflow-noise)	4 SPEED * (airflow-noise)	5 SPEED * (airflow-noise)
Sweet	A	230 m³/h - 46 db(A)	335 m³/h - 54 db(A)	465 m³/h - 61 db(A)	---	580 m³/h - 66 db(A)
Synthesis	C	240 m³/h - 44 db(A)	368 m³/h - 55 db(A)	496 m³/h - 63 db(A)	---	559 m³/h - 67 db(A)
Tamaya 2.0	D	290 m³/h - 56 db(A)	375 m³/h - 61 db(A)	435 m³/h - 65 db(A)	---	---
Thin	A	145 m³/h - 34 db(A)	300 m³/h - 47 db(A)	385 m³/h - 52 db(A)	560 m³/h - 60 db(A)	680 m³/h - 64 db(A)
Thin Island	A	145 m³/h - 34 db(A)	300 m³/h - 47 db(A)	385 m³/h - 52 db(A)	560 m³/h - 60 db(A)	680 m³/h - 64 db(A)
Tonda	D	265 m³/h - 60 db(A)	325 m³/h - 65 db(A)	355 m³/h - 67 db(A)	---	---
Tribe	A	255 m³/h - 48 db(A)	365 m³/h - 57 db(A)	500 m³/h - 64 db(A)	---	600 m³/h - 69 db(A)
Tribe Island	A	255 m³/h - 48 db(A)	365 m³/h - 57 db(A)	500 m³/h - 64 db(A)	---	600 m³/h - 69 db(A)
Tube Pro	C	240 m³/h - 47 db(A)	368 m³/h - 56 db(A)	603 m³/h - 68 db(A)	---	---
Tube Pro Island	C	240 m³/h - 47 db(A)	368 m³/h - 56 db(A)	603 m³/h - 68 db(A)	---	---
Vega	D	125 m³/h - 50 db(A)	165 m³/h - 55 db(A)	265 m³/h - 64 db(A)	---	---
Vertigo	B	310 m³/h - 50 db(A)	450 m³/h - 59 db(A)	610 m³/h - 66 db(A)	---	740 m³/h - 70 db(A)
Wave UX	A	265 m³/h - 46 db(A)	365 m³/h - 55 db(A)	515 m³/h - 62 db(A)	---	610 m³/h - 66 db(A)
Ye	A	300 m³/h - 50 db(A)	395 m³/h - 57 db(A)	540 m³/h - 64 db(A)	---	700 m³/h - 70 db(A)
Zenith	B	275 m³/h - 49 db(A)	380 m³/h - 57 db(A)	510 m³/h - 63 db(A)	---	650 m³/h - 68 db(A)

	ENERGY CLASS	1 SPEED m³/h-db(A)	2 SPEED m³/h-db(A)	3 SPEED m³/h-db(A)	4 SPEED m³/h-db(A)	5 SPEED m³/h-db(A)	6 SPEED m³/h-db(A)	7 SPEED m³/h-db(A)	8 SPEED m³/h-db(A)	9 SPEED m³/h-db(A)	BOOSTER 1* m³/h-db(A)	BOOSTER 2* m³/h-db(A)
NT ALPHA (Duct-out)	A	205 - 43	320 - 53	385 - 57	455 - 61	---	---	---	---	---	580 - 67	---
NT FIT (Duct-out)	A	220 - 37	340 - 52	400 - 56	500 - 61	---	---	---	---	---	620 - 67	---
NT FIT XL (Duct-out)	A	220 - 43	340 - 52	410 - 57	500 - 61	---	---	---	---	---	620 - 66	---
NT FLAME (Duct-out)	A	175 - 45	275 - 53	410 - 63	---	---	---	---	---	---	515 - 68	600 - 71
NT FLAME (Filtering)	A	155 - 49	275 - 60	410 - 69	---	---	---	---	---	---	490 - 72	530 - 74
NT LIBRA (Duct-out)	A	185 - 46	285 - 54	430 - 63	540 - 69	---	---	---	---	---	610 - 72	---
NT LIBRA (Filtering)	A	170 - 48	275 - 58	415 - 67	495 - 71	---	---	---	---	---	545 - 73	---
NT ONE / ONE HP (Duct-out)	A+	130 - 34	205 - 44	235 - 47	280 - 51	305 - 54	335 - 56	370 - 58	415 - 61	500 - 66	640 - 72	---
NT ONE / ONE HP (Filtering)	A+	105 - 40	170 - 50	200 - 53	235 - 57	260 - 59	290 - 62	320 - 64	360 - 67	400 - 72	545 - 77	---
NT PRIME S (Duct-out)	A	225 - 36	340 - 54	405 - 59	535 - 63	---	---	---	---	---	620 - 69	---
NT PRIME S (Filtering)	A	135 - 49	295 - 59	360 - 63	460 - 69	---	---	---	---	---	535 - 72	---
NT SWITCH / SWITCH GLOW (Duct-out)	A+	135 - 33	190 - 41	220 - 44	260 - 49	290 - 52	315 - 54	350 - 57	400 - 60	500 - 66	630 - 71	---
NT SWITCH / SWITCH GLOW (Filtering)	A+	110 - 39	160 - 48	190 - 51	230 - 55	255 - 58	280 - 60	310 - 62	350 - 66	400 - 72	550 - 76	---
NT UNPLUGGED (Duct-out)	A+	135 - 33	190 - 41	220 - 44	260 - 49	290 - 52	315 - 54	350 - 57	400 - 60	500 - 66	630 - 71	---
NT UNPLUGGED (Filtering)	A+	110 - 39	160 - 48	190 - 51	230 - 55	255 - 58	280 - 60	310 - 62	350 - 66	400 - 72	550 - 76	---

* Velocità intensive temporizzate *Booster time speeds

** Modello non soggetto a certificazione energetica obbligatoria *Model not subject to compulsory energy certification.

APPROFONDIMENTI LEARN MORE

	REDUCTION 150/125	ODOUR FILTER ALERT	GREASE FILTER ALERT	NO RETURN VALVE
Acuta	---	√	√	√
Adèle	√	√	√	√
Adèle Island	√	√	√	√
Aplomb	---	√	√	√
Belt	---	√	√	√
Bio	---	√	√	√
Bio Island	---	√	√	√
Bloom	---	√	√	√
Bloom-S	---	√	√	√
Boxin	√	---	---	---
Boxin Advance	√	√	√	√
Boxin Dry	√	√	√	√
Boxin Lx	√	---	---	√
Boxin No Drip	√	√	√	---
Boxin Plus	√	---	---	√
Ciak 2.0	---	---	---	√
Ciak 2.0 S	---	---	---	√
Circus	√	---	---	---
Cloud Seven	---	√	√	---
Cruise	---	√	√	√
CT35 PRO	---	---	√	√
Easy UX	---	√	√	---
Edith	---	√	√	---
Elite 14	---	---	---	√
Elite 35	---	√	√	√
Elle	---	√	√	√
Era	---	---	---	√
Era C	---	---	---	√
Era S	---	---	---	√
Estraibile	---	---	---	---
Flat Glass	√	---	---	√
Fold	√	---	---	√
Fold S	√	---	---	√
Galaxy	---	√	√	√
Galaxy Island	---	√	√	√
Getup	---	√	√	---
Glass Out	---	√	√	√
Haiku	√	√	√	√
Haiku Island	√	√	√	√
Hidden 2.0	√	√	√	√
Hidden 2.0 @	√	√	√	√
Hidden 2.0 Advance	√	√	√	√
Hiilight Glass H16/H30	---	√	√	---
Hiilight-X H16/H30	---	√	√	---
Hydra	---	---	---	---
Ikona	---	√	√	√
Ikona Light	---	√	√	---
ikona Maxxi Pure	---	√	√	---
Illusion H16/H30	---	√	√	---
Interstellar	---	√	√	---
Joy	√	√	√	---
Joy Island	---	√	√	√
Juno	---	---	---	---
Juno Urban	---	---	---	---
Krea ST	---	---	---	---
Krea GFA	---	---	---	---
Krea LUX	---	---	---	---
Kuadra Island	√	√	√	√
Lane	√	√	√	√
Lever	---	---	---	√

APPROFONDIMENTI LEARN MORE

	REDUCTION 150/125	ODOUR FILTER ALERT	GREASE FILTER ALERT	NO RETURN VALVE
Lol	---	√	√	√
Lullaby	---	√	√	---
Majestic	---	√	√	√
Majestic No Drip	---	√	√	√
Meteorite	---	√	√	√
Meteorite Island	---	√	√	√
Missy	---	---	---	√
Moon Island	---	√	√	---
Nuage	---	√	√	---
Om Air	---	√	√	---
Open Suite	---	√	√	---
Open Suite Superior	---	√	√	---
Pandora	---	√	√	---
Pix	---	√	√	---
Plat	---	√	√	---
Reef	---	√	√	√
Reef Island	---	√	√	√
Rubino Corner	√	---	---	---
Rules	---	√	√	√
Seashell	---	---	---	---
Sheen-s	---	√	√	√
Shining	---	√	√	---
Shire	---	√	√	√
Shy-S	---	√	√	√
Skydome H16/H30	---	√	√	---
Spot NG	√	---	---	---
Spot Plus	√	√	√	---
Spot Plus Island	√	√	√	---
Spot Urban	√	---	---	√
Stone	---	---	---	---
Stripe	---	√	√	√
Stripe Urban	---	√	√	√
Super Plat	---	√	√	---
Sweet Duct-out	√	√	√	√
Sweet Filtering	---	√	√	√
Synthesis	---	√	√	---
Tamaya 2.0	---	---	---	√
Thin	---	√	√	√
Thin Island	√	√	√	√
Tonda	√	---	---	---
Tribe	---	√	√	√
Tribe Island	---	√	√	√
Tube Pro	---	---	---	√
Tube Pro Island	√	---	---	√
Vega	---	---	---	---
Vertigo	---	√	√	√
Wave UX	---	√	√	---
Ye	---	---	---	√
Zenith	√	---	---	√

ATTENZIONE AL PESO DELLA CAPPA

LEARN MORE ABOUT WEIGHT

Nei casi in cui il nostro progetto cucina preveda una cappa di tipo a isola, sospesa o inserita in un controsoffitto (ceiling), è buona norma fare attenzione nel realizzare una struttura in cartongesso che possa sostenere il peso della cappa stessa.

Il peso varia a seconda dei modelli e degli ingombri e la tabella seguente è un valido aiuto per costruire un sostegno adeguato senza dover rinunciare ad un open space pratico e di tendenza.

In kitchen designs featuring an island, suspended or ceiling hood (built into a false ceiling), it is important that the plasterboard structure is able to support the weight of the hood itself.

The weight varies depending on the model and overall dimensions, and the following table is a useful aid in developing a suitable support without needing to forgo a practical and stylish open space.

	PESO NETTO WEIGHT
ADÉLE ISLAND	29,00 Kg
BIO ISLAND	32,80 Kg
CLOUD SEVEN (DUCT-OUT)	17,70 Kg
CLOUD SEVEN (FILTERING)	19,50 Kg
EASY UX	11,65 Kg
EDITH	19,25 Kg
GALAXY ISLAND	24,50 Kg
HAIKU ISLAND (32 cm)	33,70 Kg
HAIKU ISLAND (120 cm)	46,30 Kg
HAIKU ISLAND (180 cm)	55,10 Kg
HILIGHT GLASS (H16)	29,10 Kg
HILIGHT GLASS (H30)	30,90 Kg
HILIGHT GLASS (NO MOTOR)	24,80 Kg
HILIGHT-X (H16)	24,00 Kg
HILIGHT-X (H30)	25,80 Kg
HILIGHT-X (NO MOTOR)	20,00 Kg
IKONA	25,00 Kg
IKONA LIGHT	11,00 Kg
IKONA MAXXI PURE	23,00 Kg
ILLUSION (H16)	23,00 Kg
ILLUSION (H30)	23,70 Kg
ILLUSION (NO MOTOR)	19,50 Kg
INTERSTELLAR	27,10 Kg
JOY ISLAND	28,75 Kg
JUNO	13,40 Kg

	PESO NETTO WEIGHT
JUNO URBAN	12,70 Kg
KUADRA ISLAND (43 cm)	28,60 Kg
KUADRA ISLAND (60 cm)	33,50 Kg
LULLABY (DUCT-OUT)	38,20 Kg
LULLABY (FILTERING)	49,10 Kg
METEORITE ISLAND	40,40 Kg
MOON ISLAND (180x60 cm)	60,30 Kg
OPEN SUITE SUPERIOR (80CM)	40,20 Kg
OPEN SUITE SUPERIOR (160CM)	67,00 Kg
PIX	16,40 Kg
REEF ISLAND	26,20 Kg
SEASHELL	33,80 Kg
SHINING	19,00 Kg
SKYDOME (H16)	25,20 Kg
SKYDOME (H30)	27,20 Kg
SKYDOME (NO MOTOR)	21,70 Kg
SPOT PLUS ISLAND	26,90 Kg
THIN ISLAND	34,20 Kg
TRIBE ISLAND	26,00 Kg
TUBE PRO ISLAND	26,35 Kg
WAVE UX	11,80 Kg
YE	66,00 Kg
ZENITH	18,5 Kg

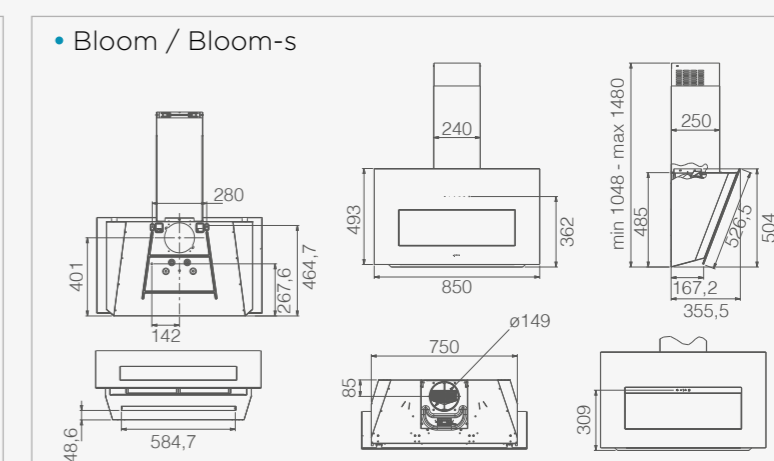
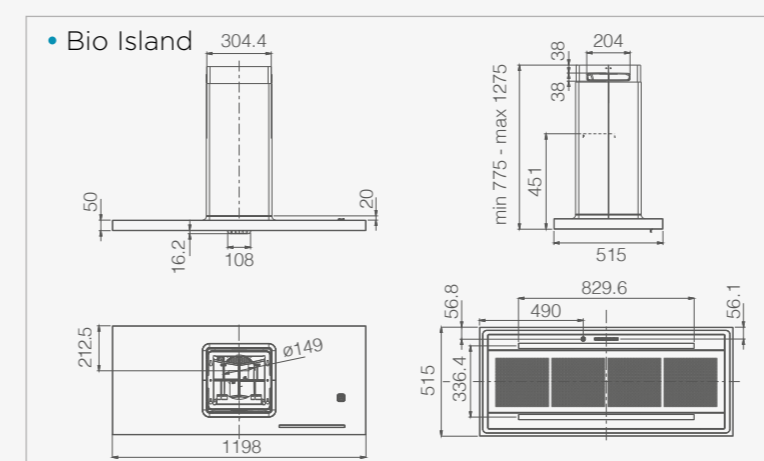
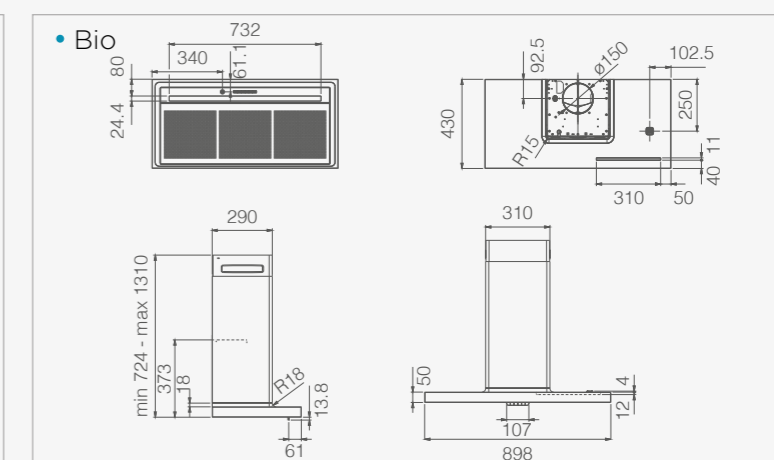
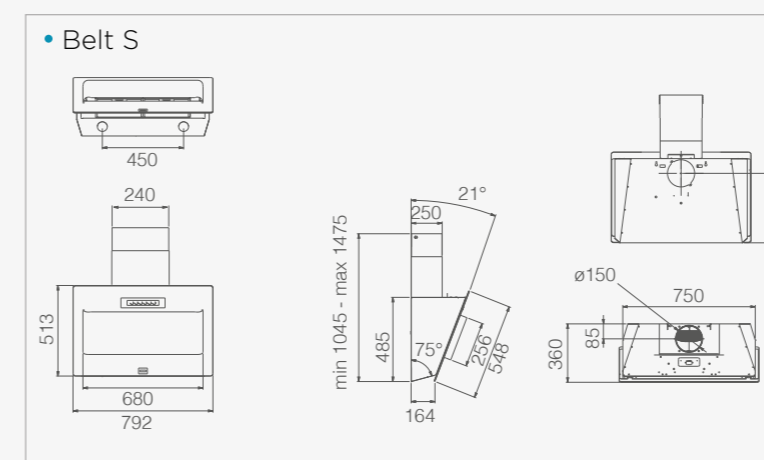
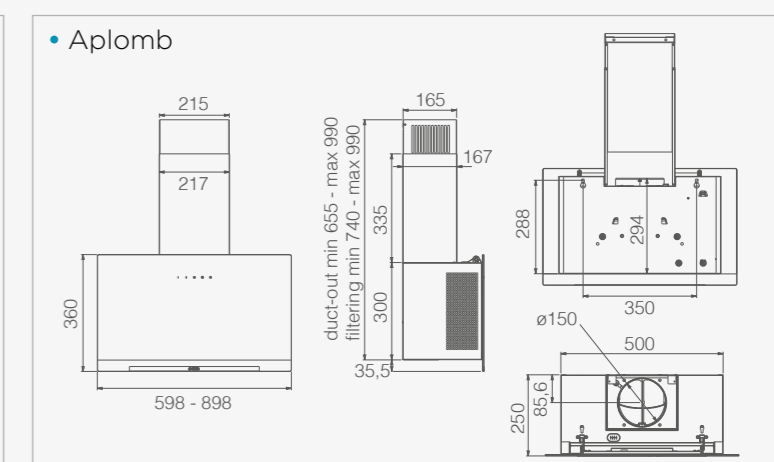
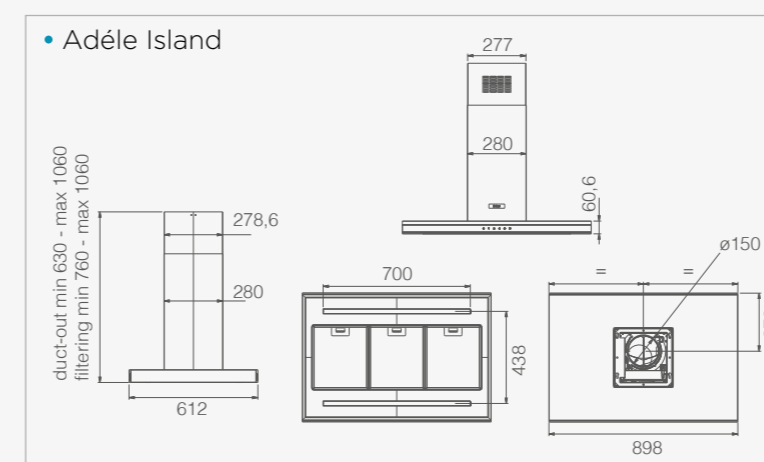
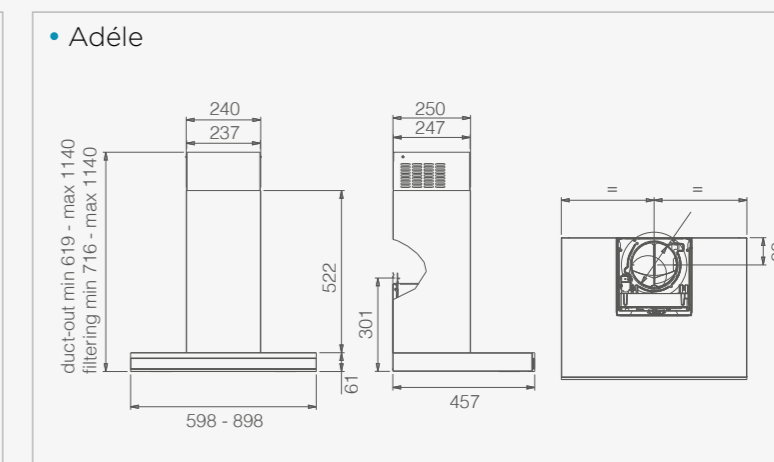
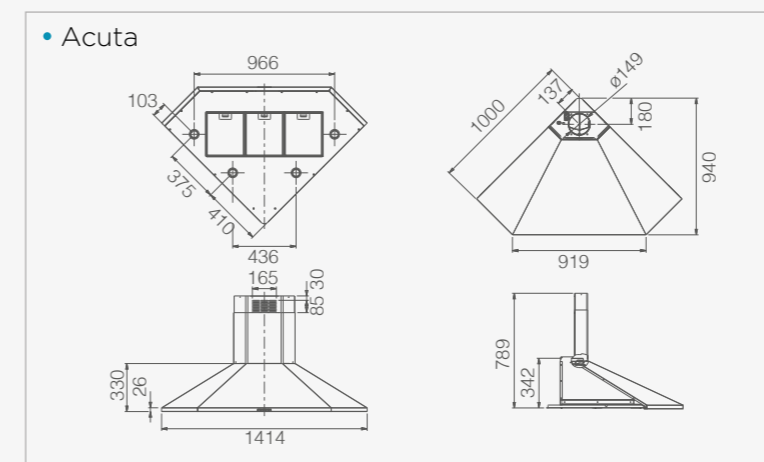

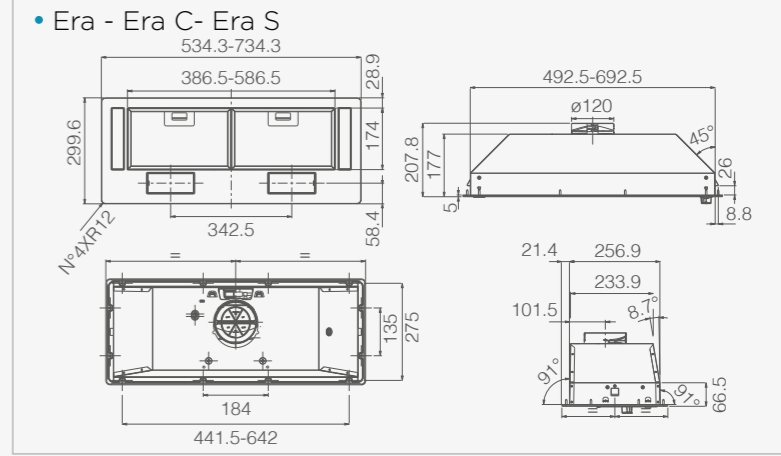
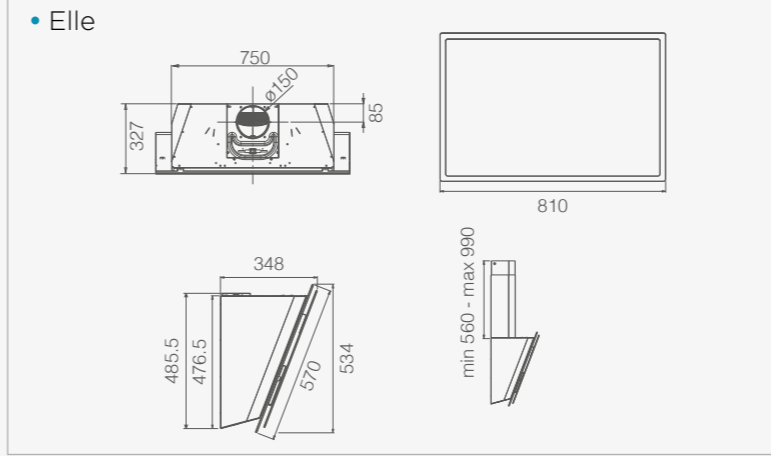
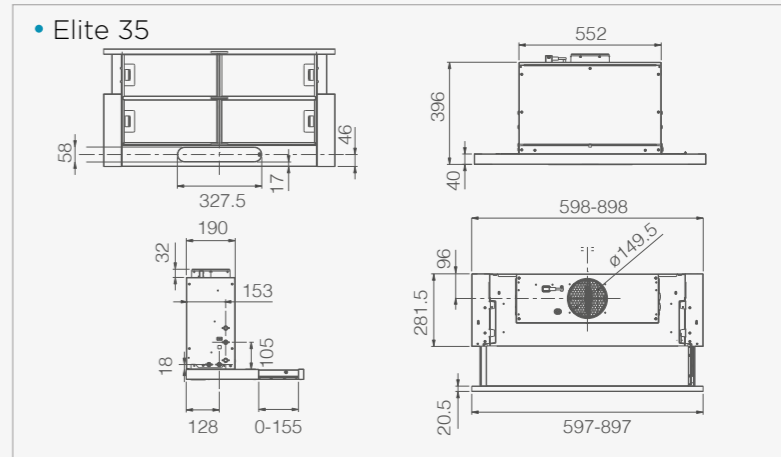
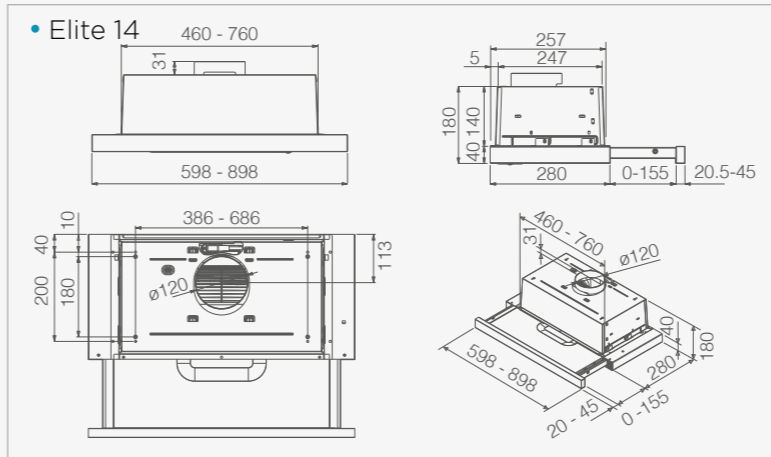
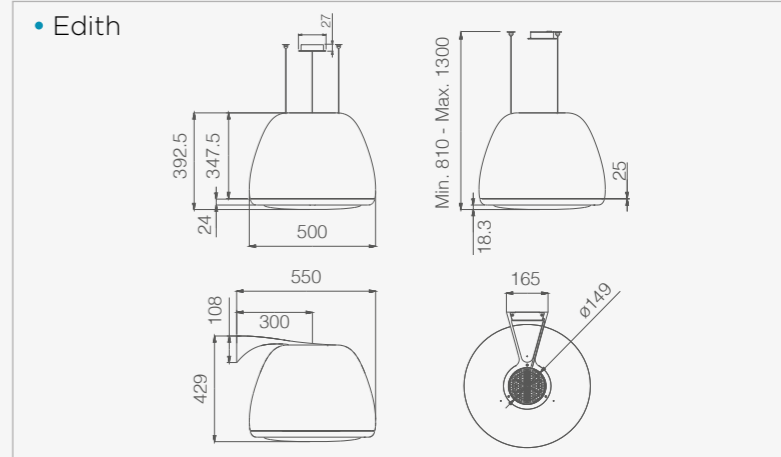
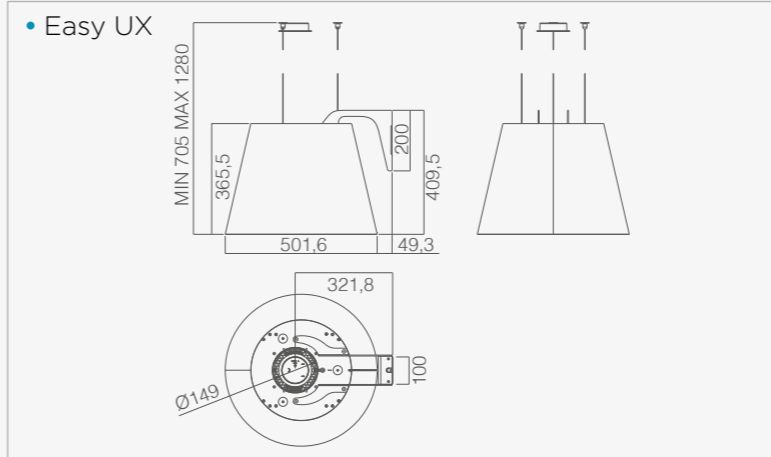
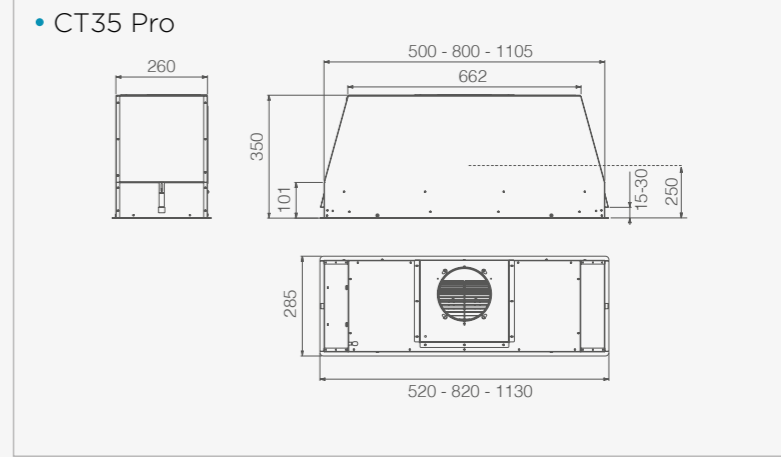
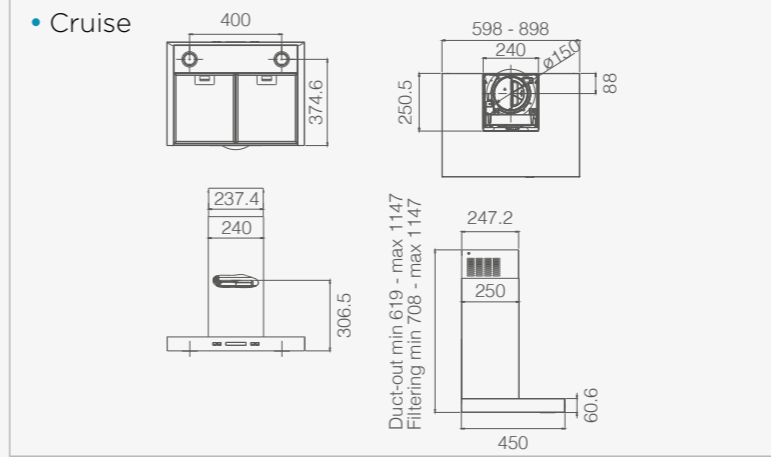
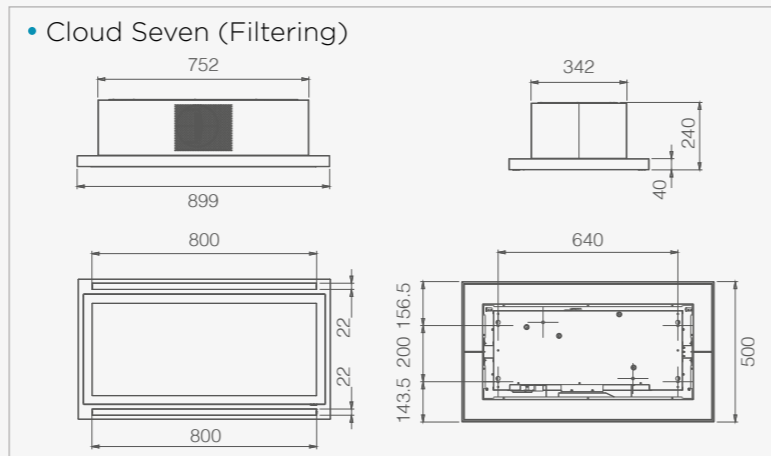
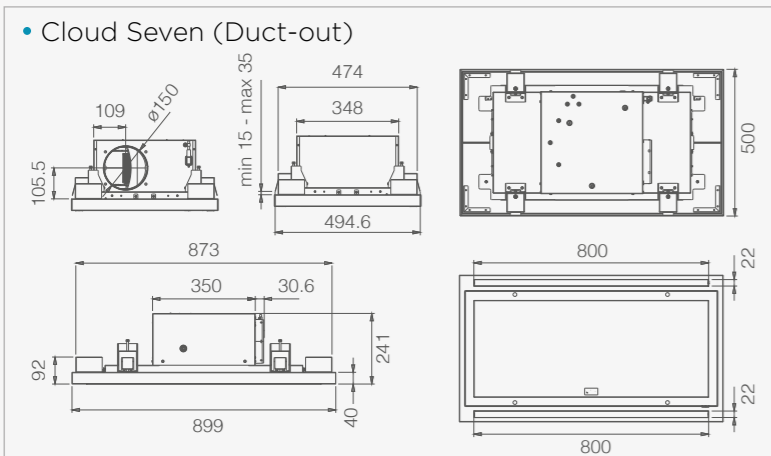
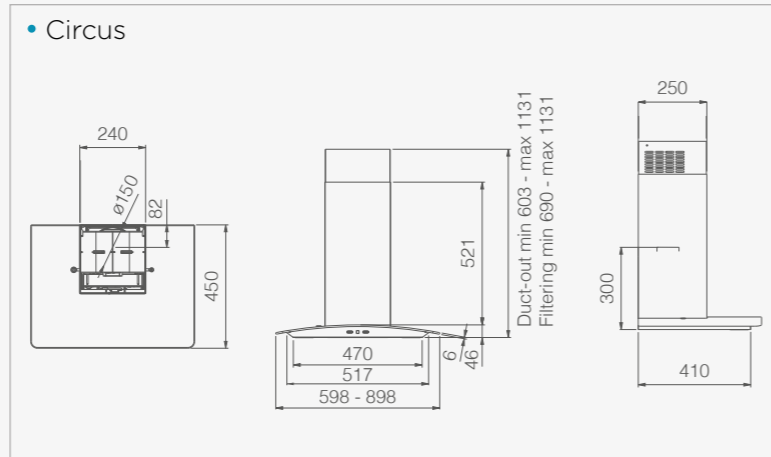
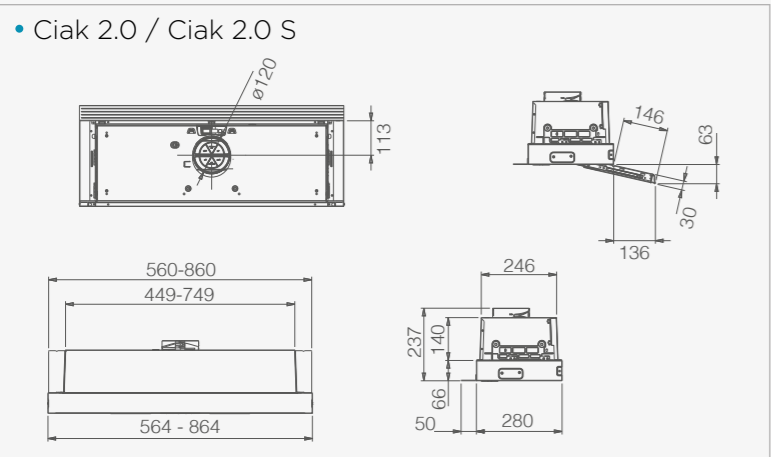
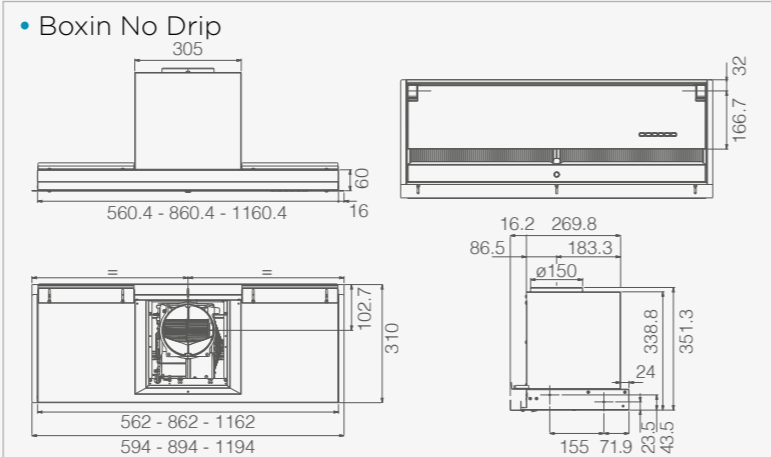
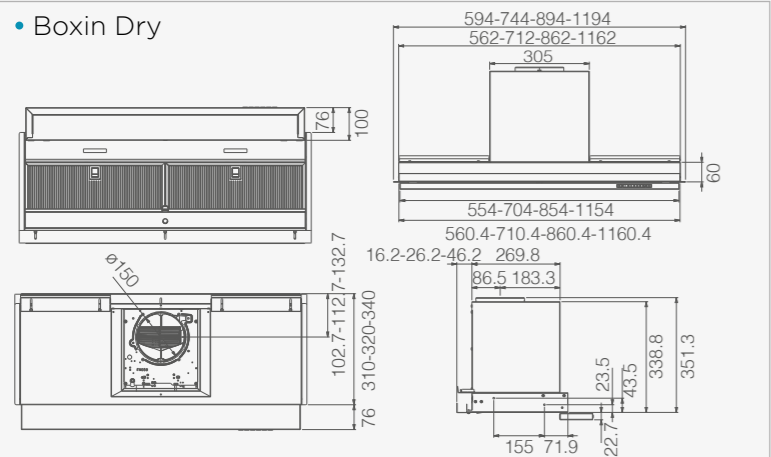
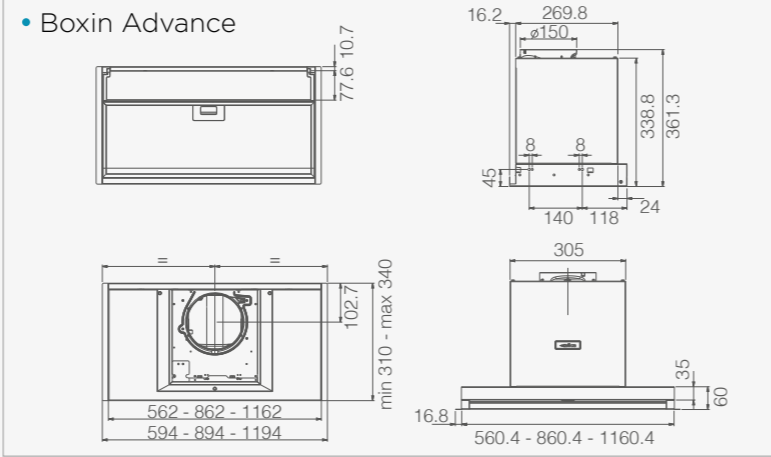
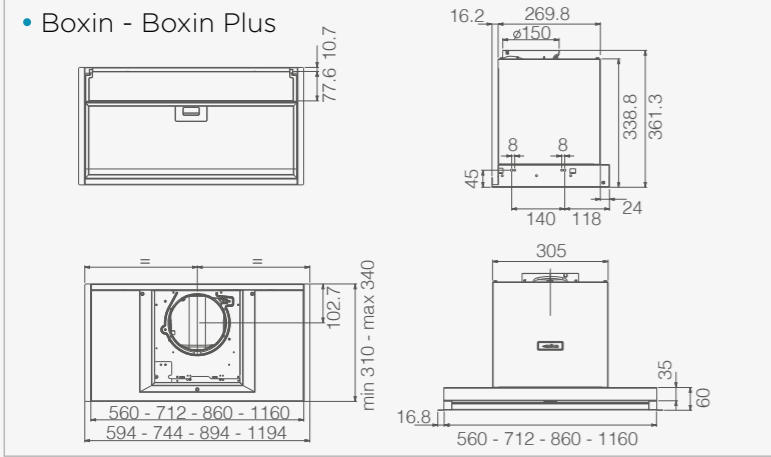

• Estraibile

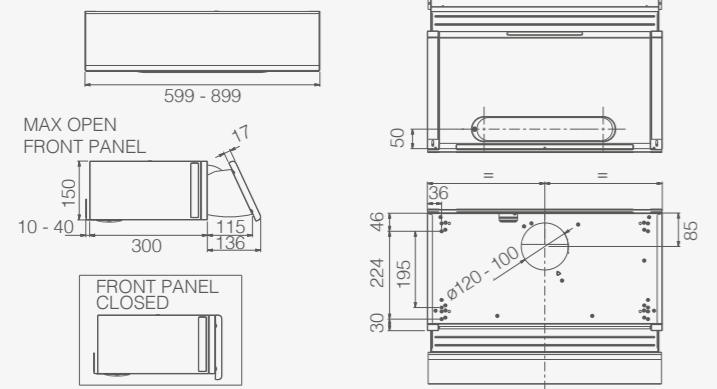

• Flat Glass

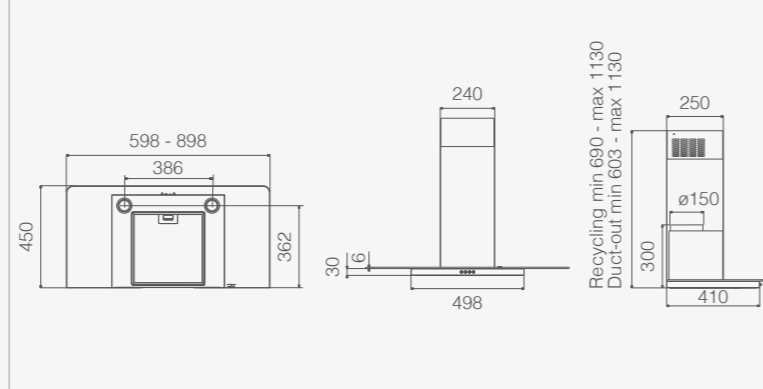

• Haiku 60-90-120cm

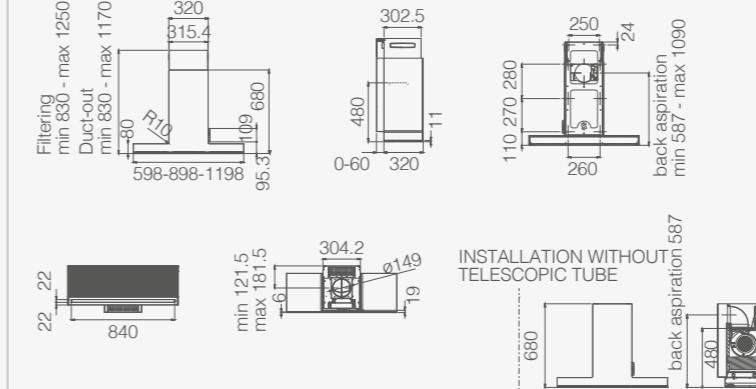

• Haiku Island 32cm

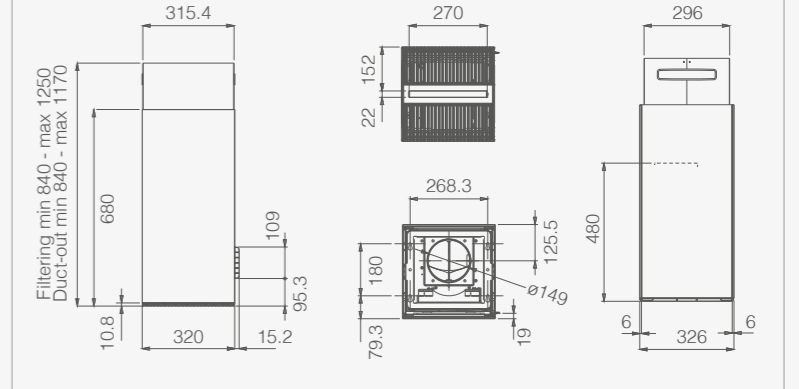

• Fold / Fold S

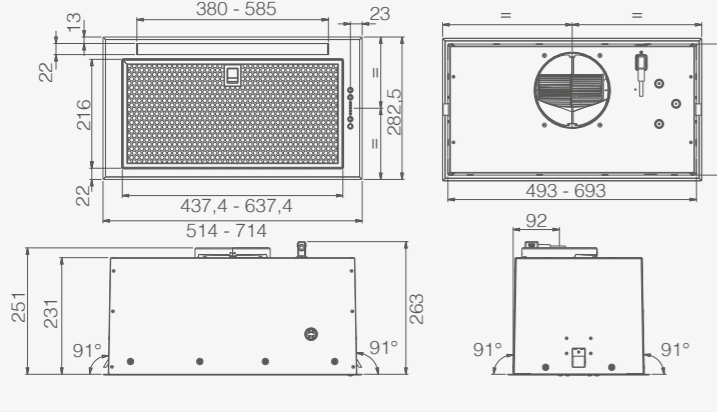

• Galaxy

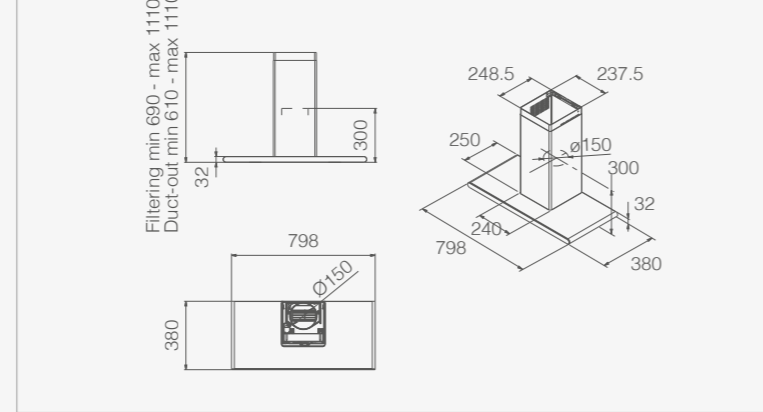

• Haiku Island 120cm

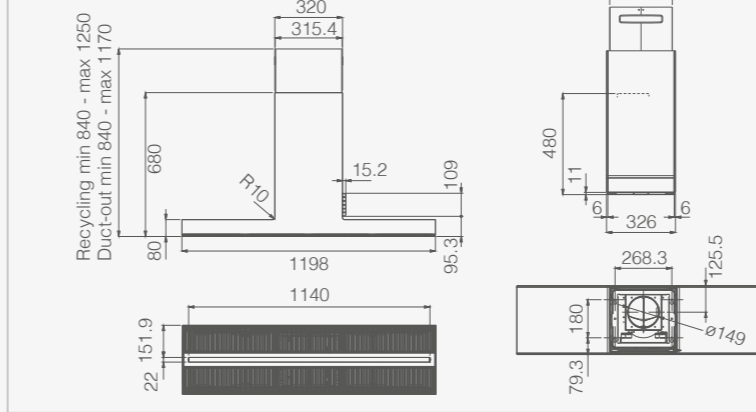

• Haiku Island 180cm

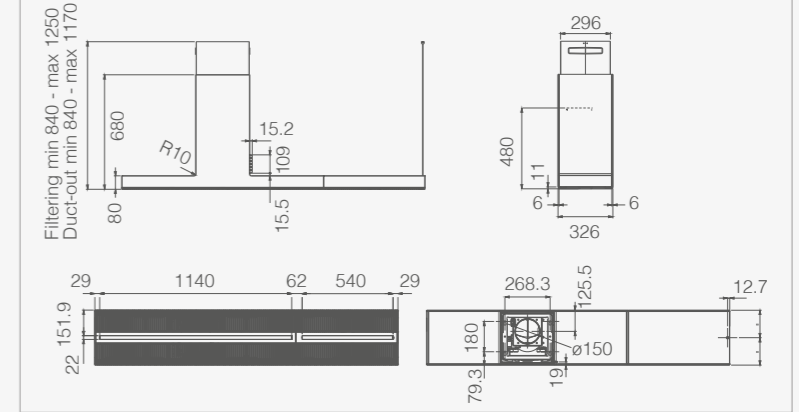

• Galaxy Island

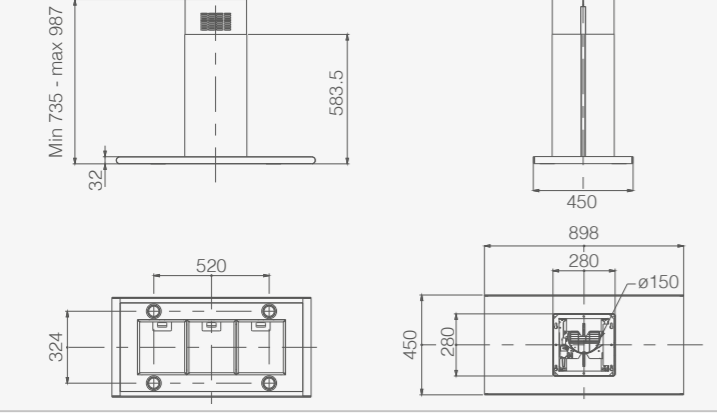

• Getup

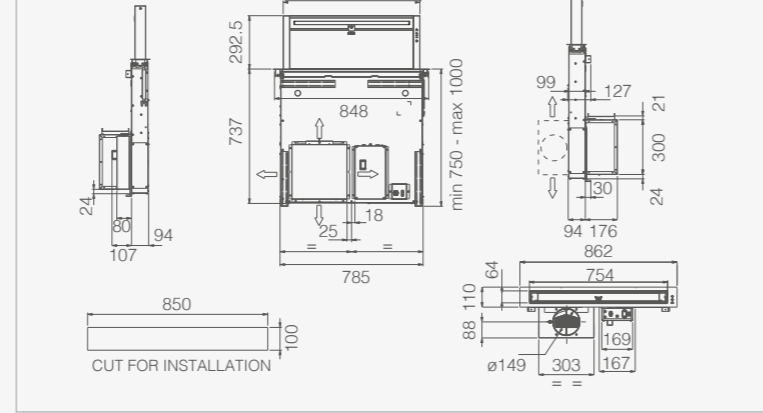

• Hidden 2.0 / Hidden 2.0 @ / Hidden Advance

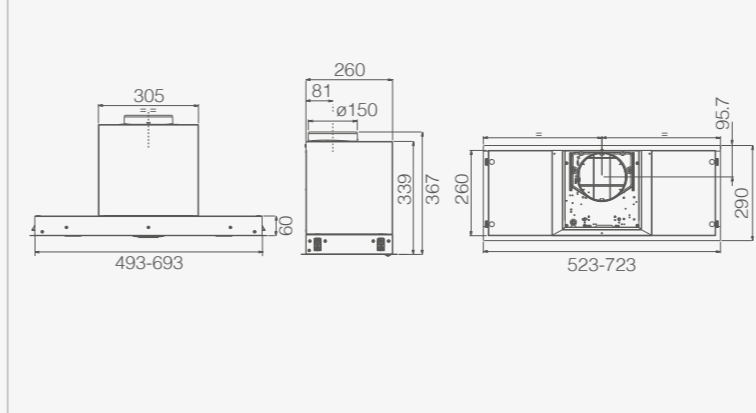

• Hilight Glass / Hilight-X (H16)

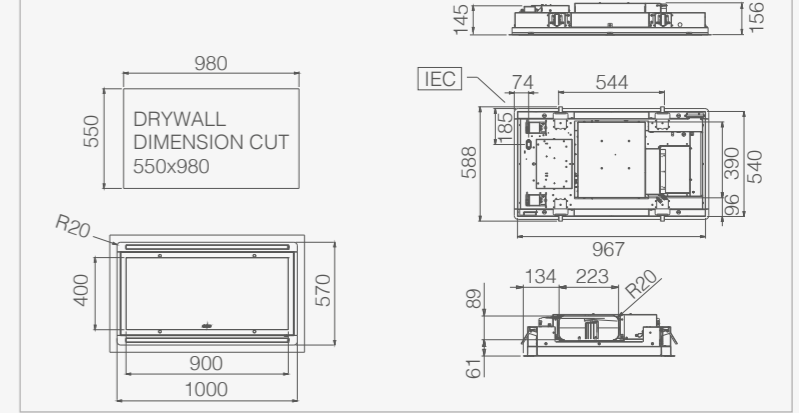

• Glass Out

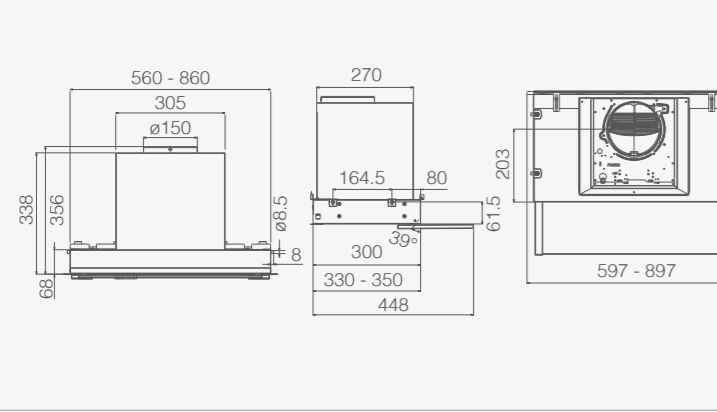

• Haiku 32cm

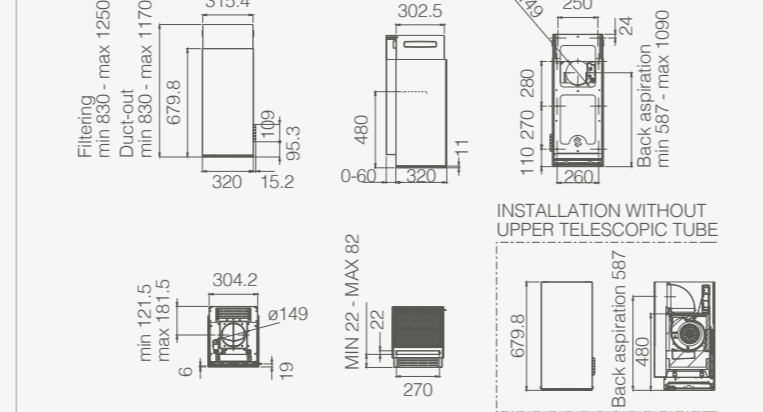

• Hilight Glass / Hilight-X (H30)

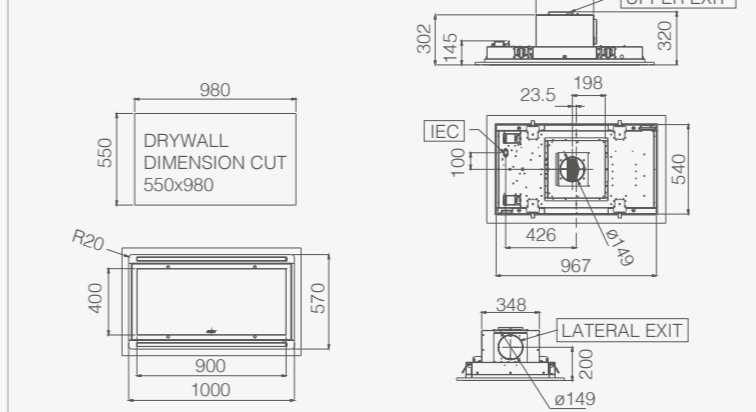

• Hilight Glass / Hilight-X (No motor)

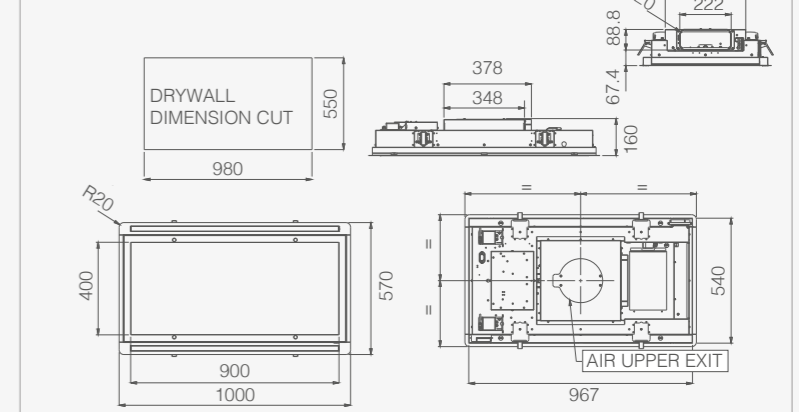

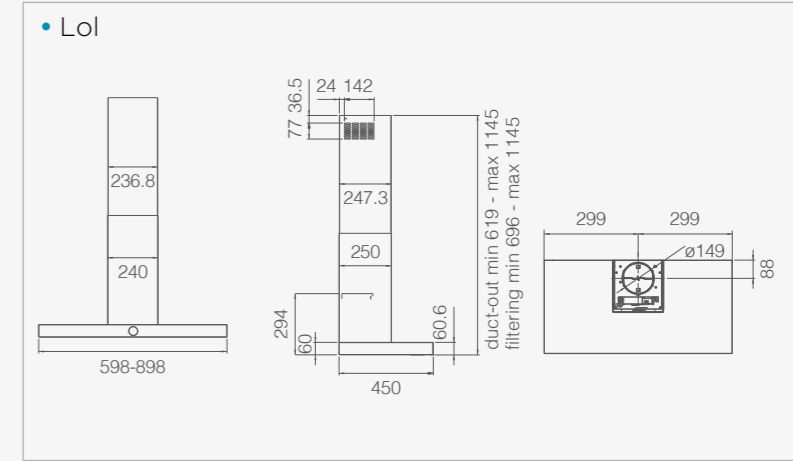
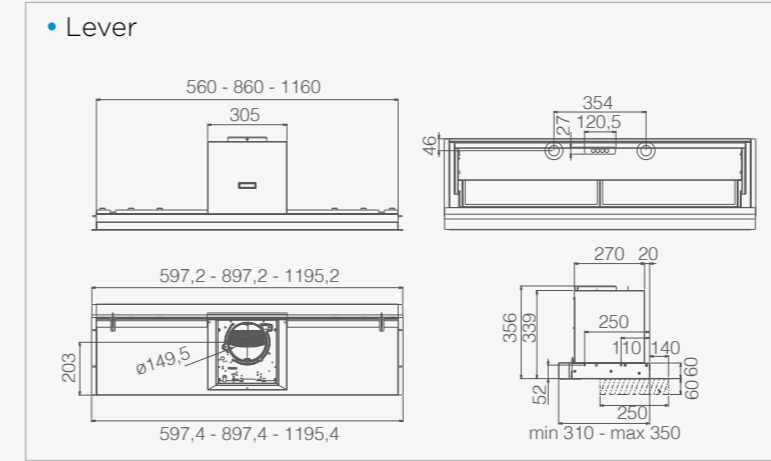
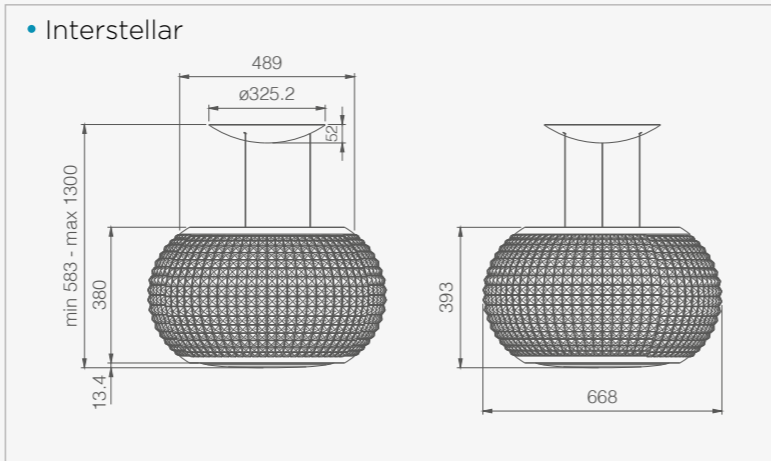
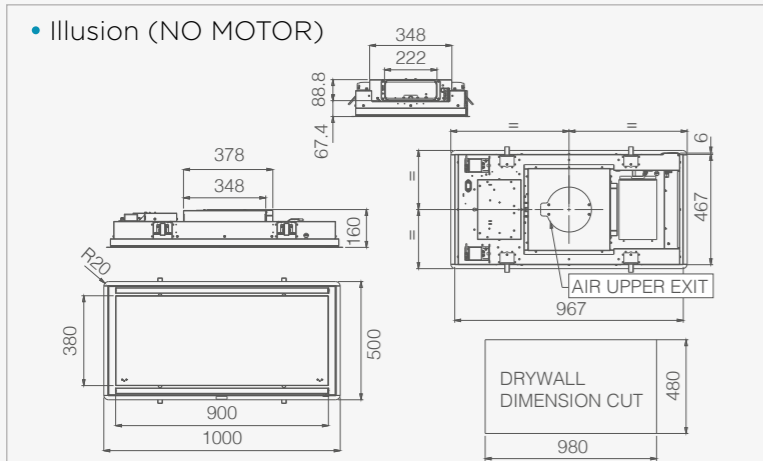
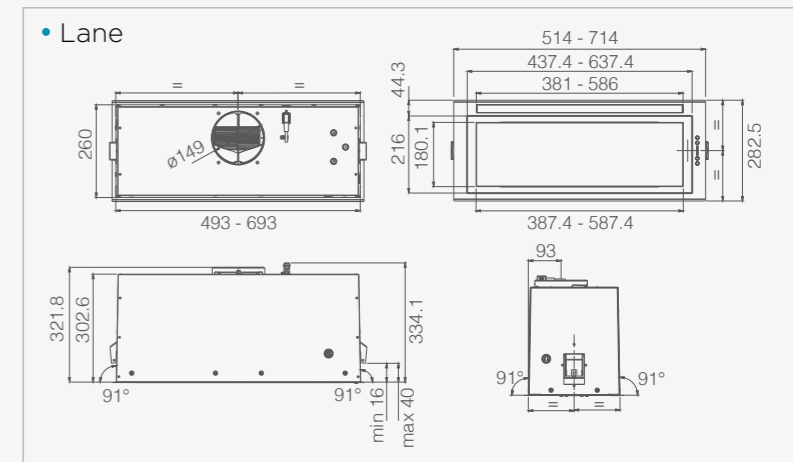
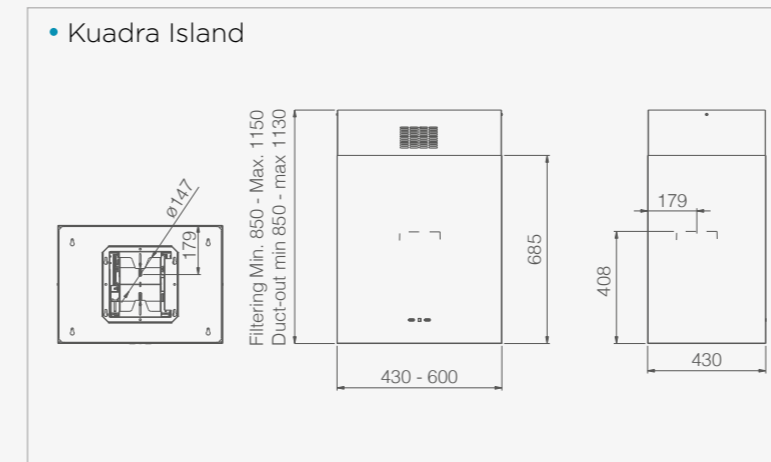
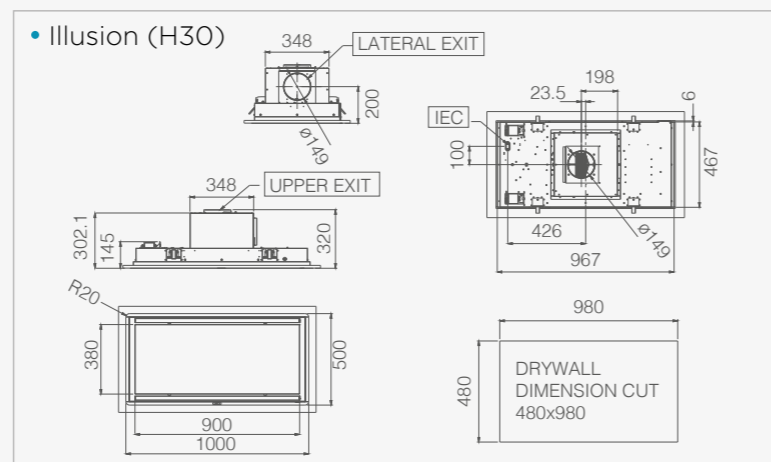
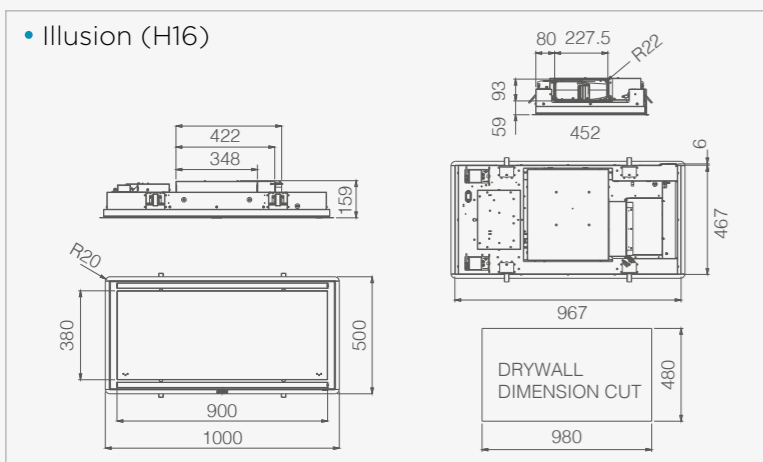
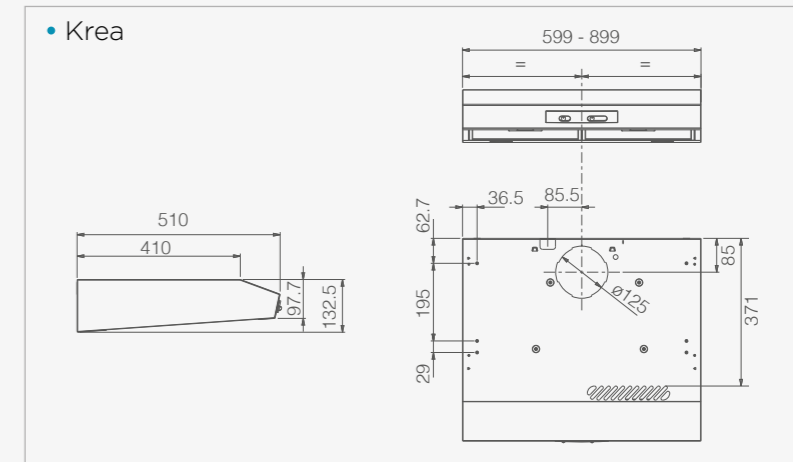
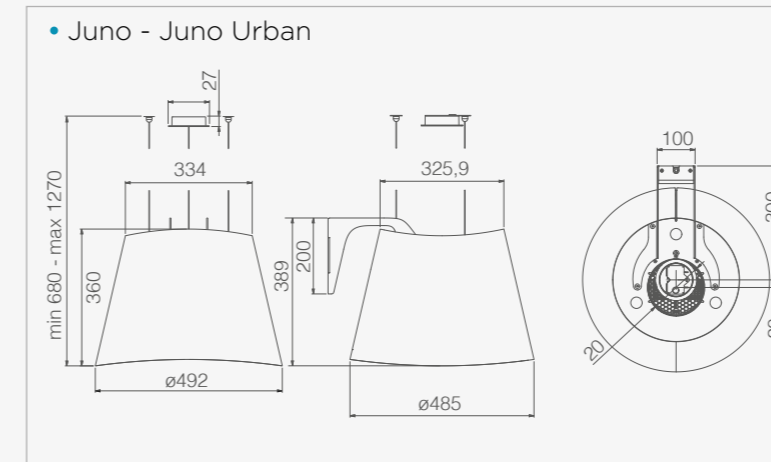
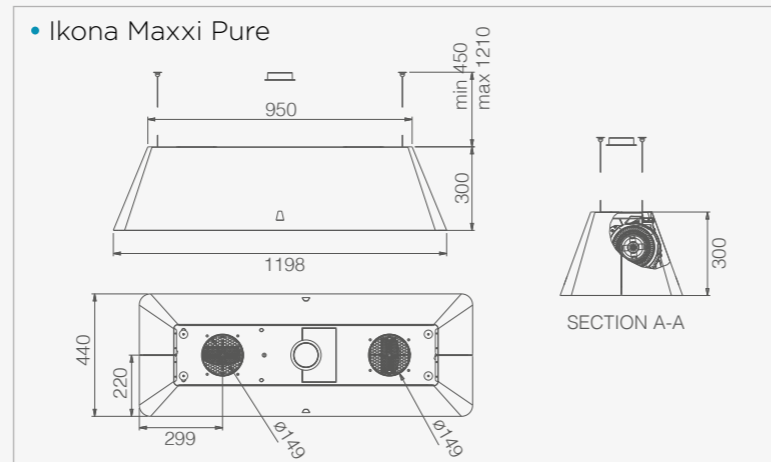
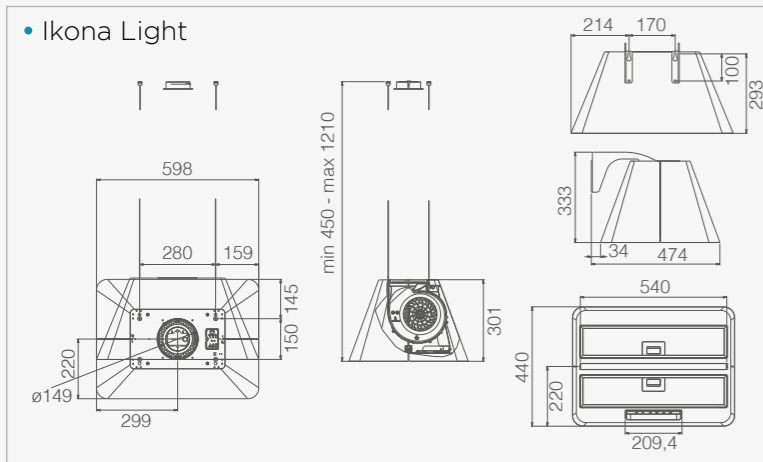
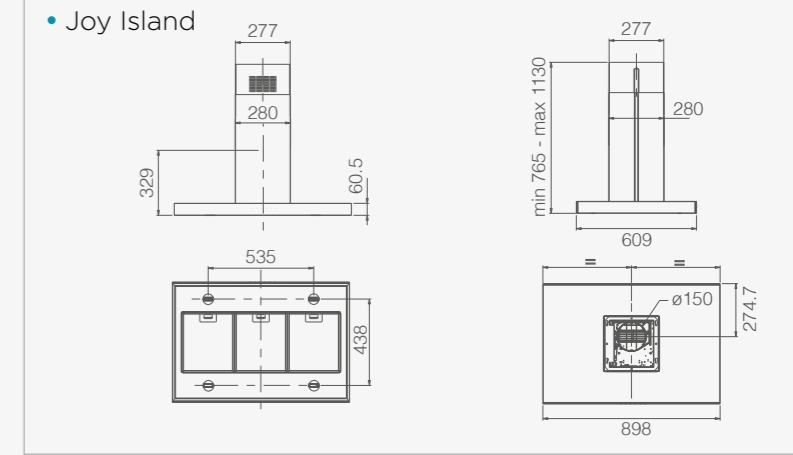
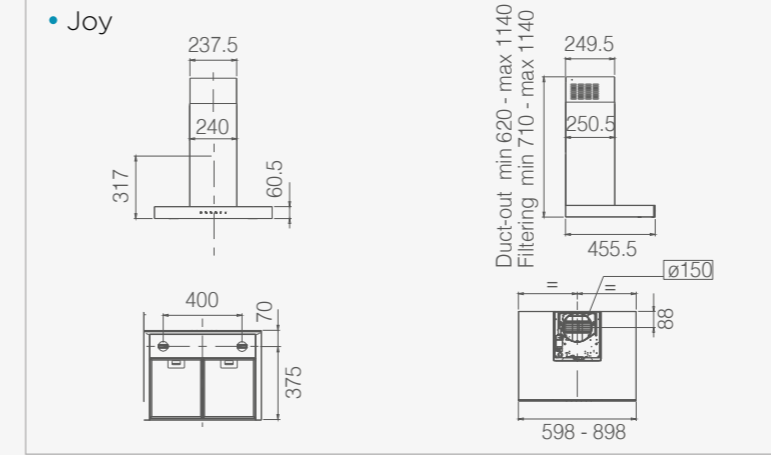
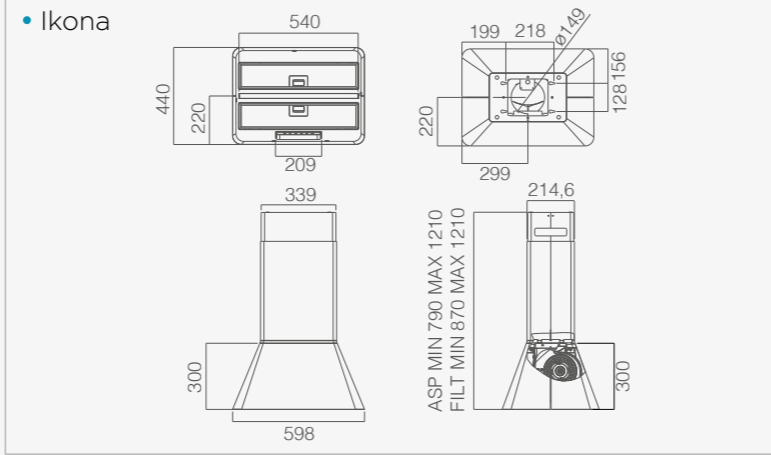
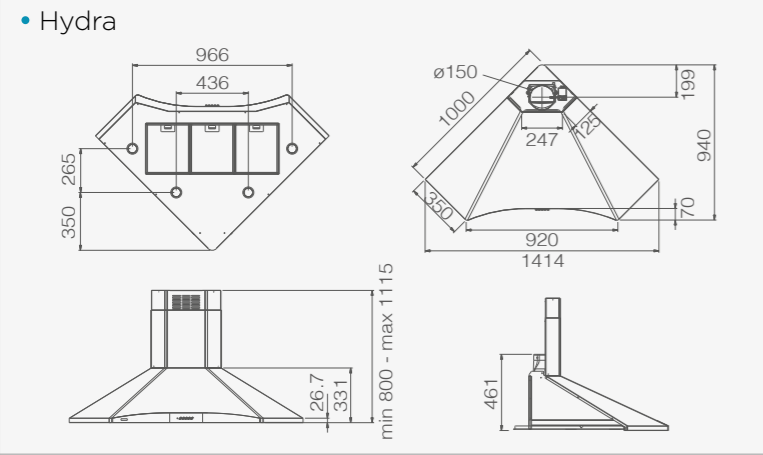

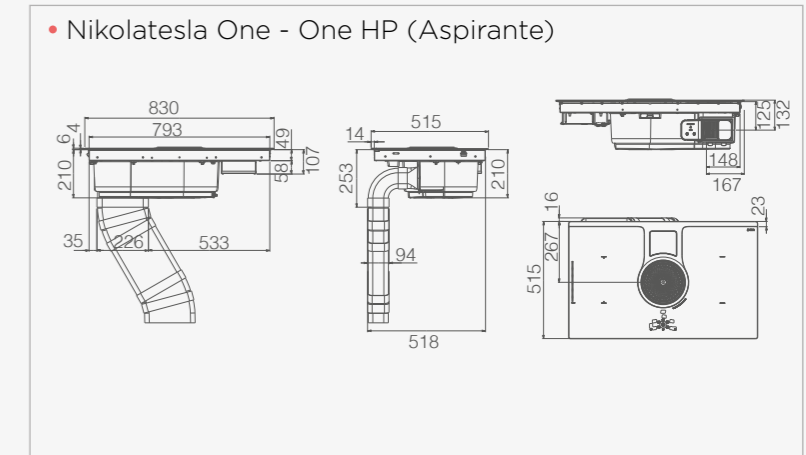
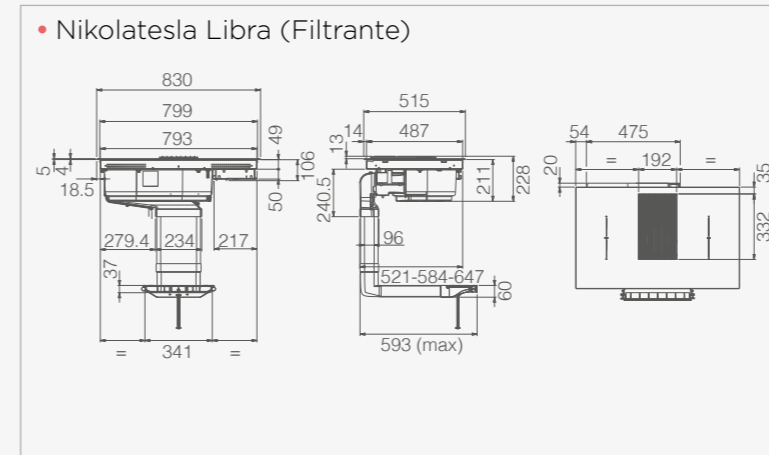
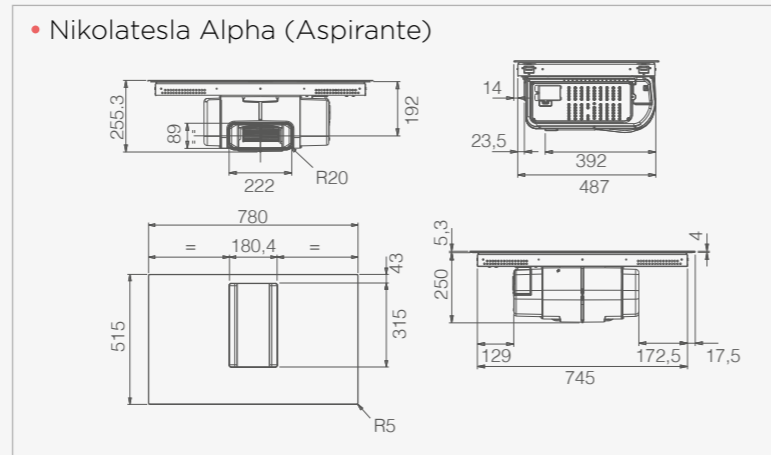
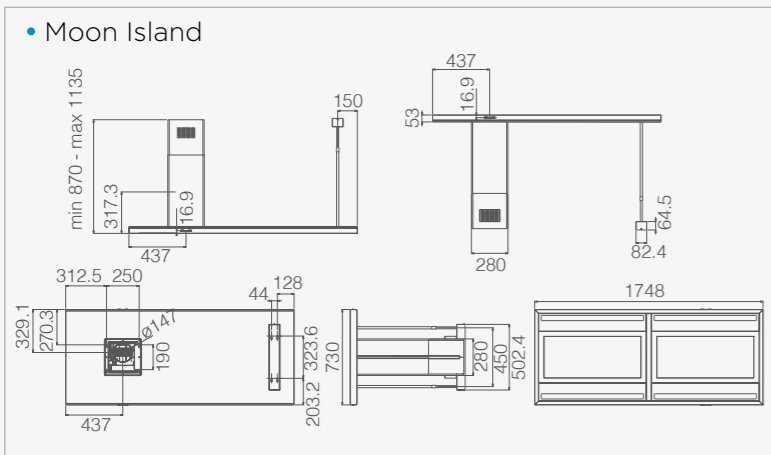
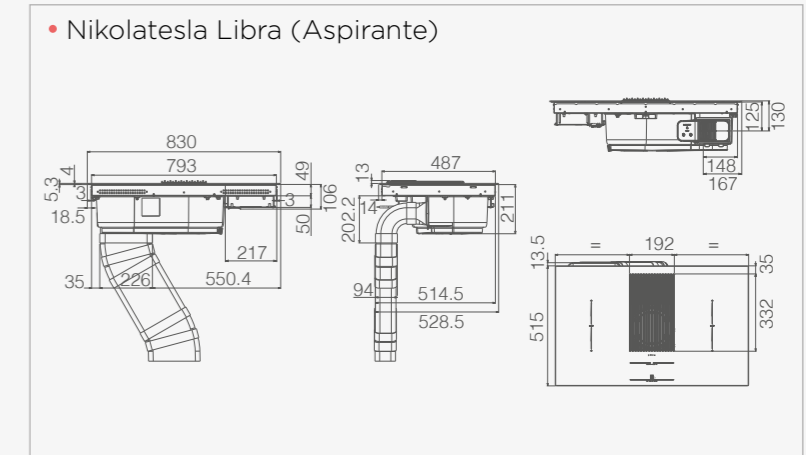
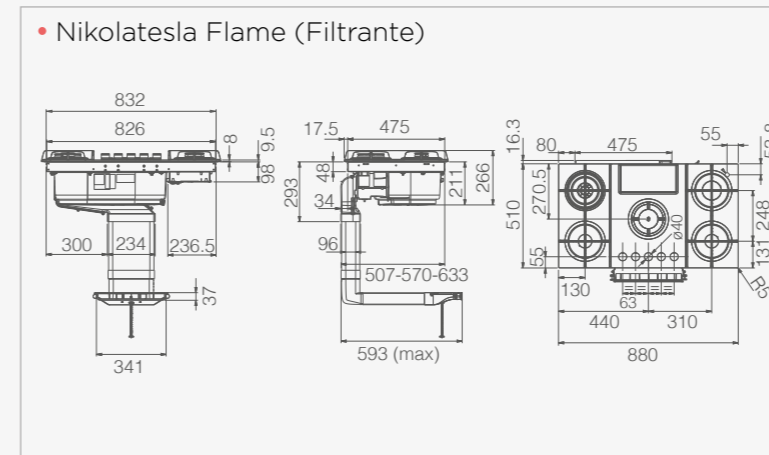
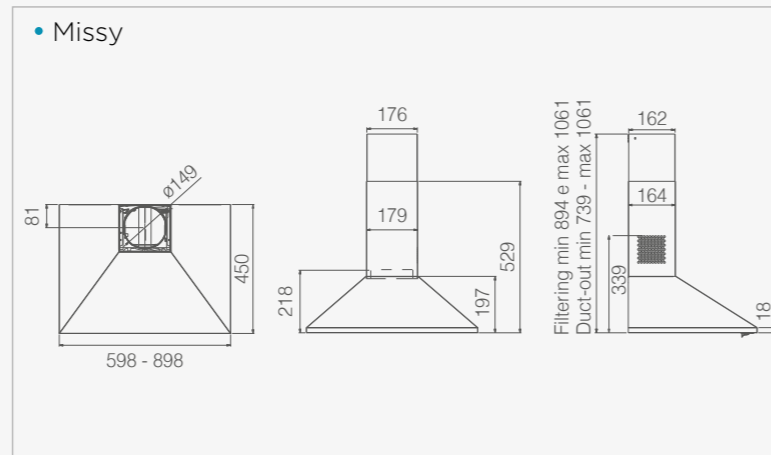
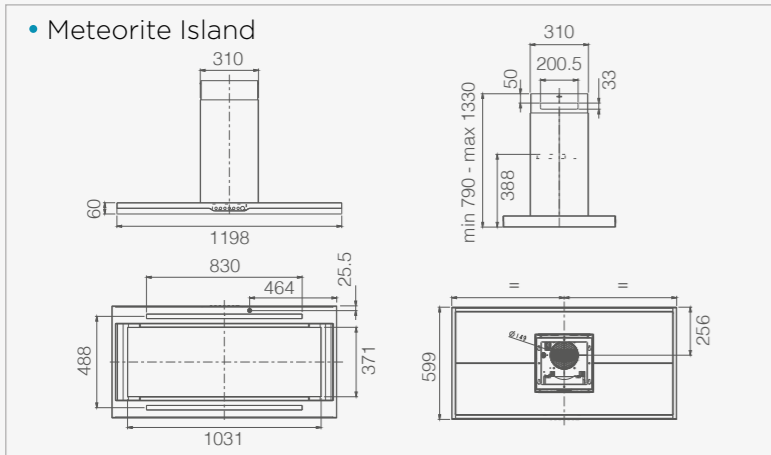
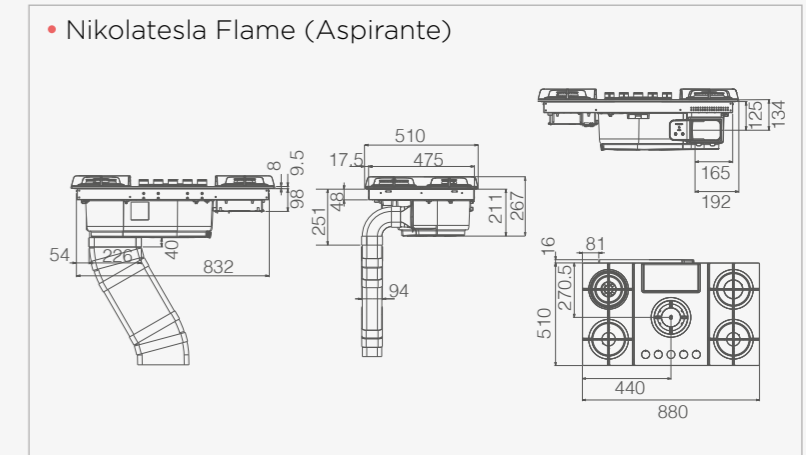
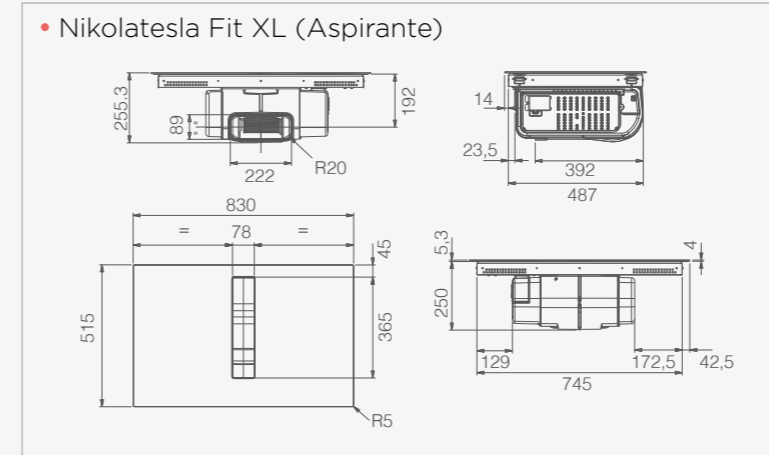
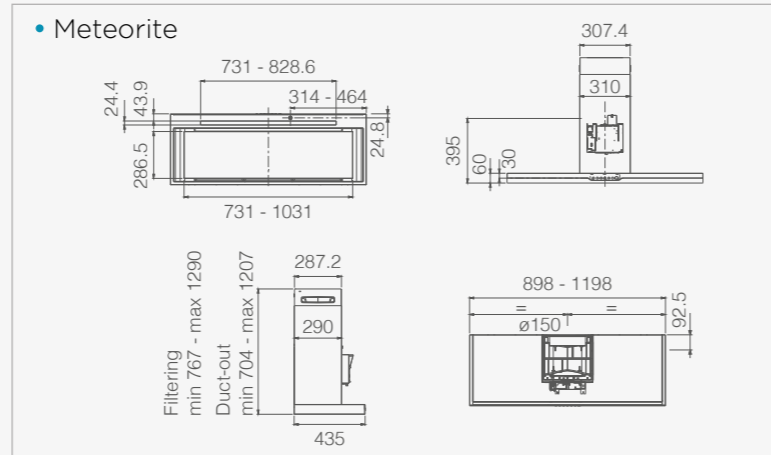
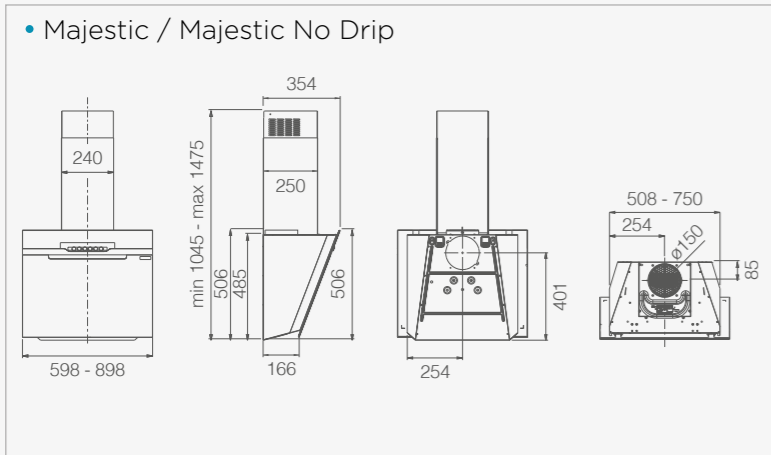
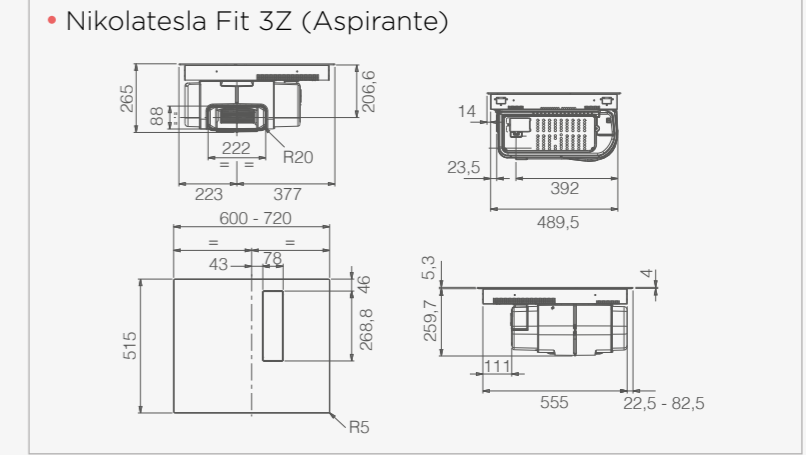
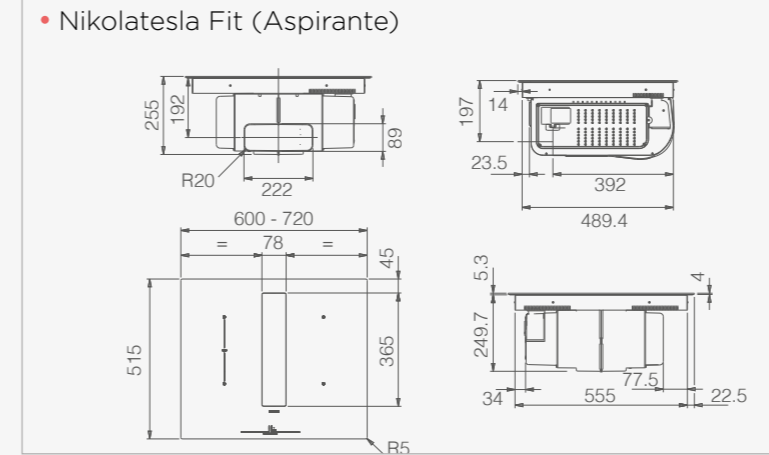
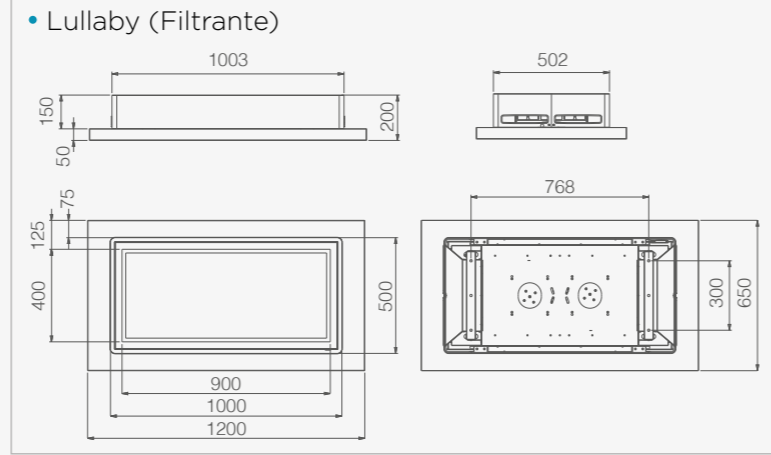
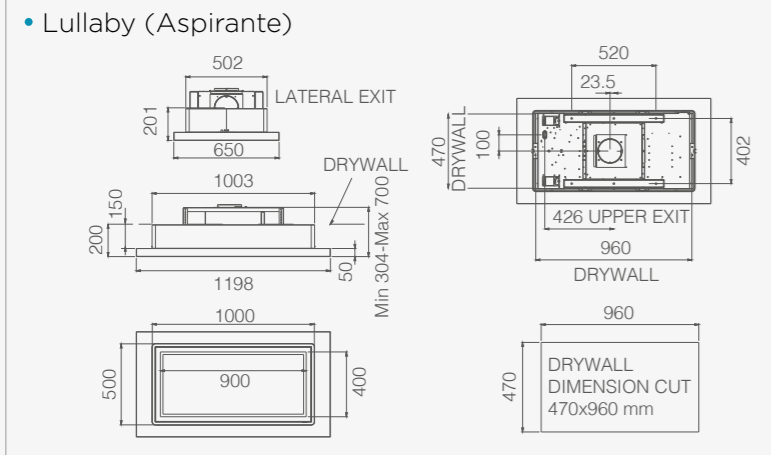

• Nikolatesla One - One HP (Filtrante)

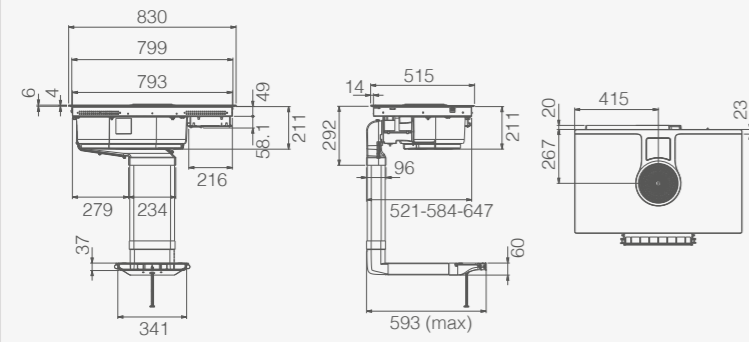

• Nikolatesla Prime S (Aspirante)

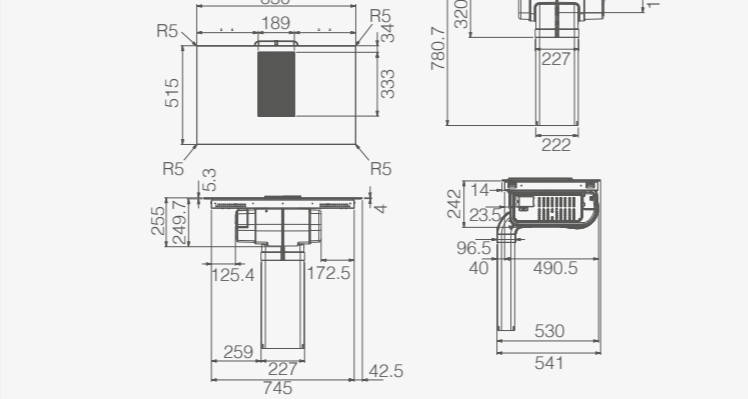

• Nikolatesla Prime S (Filtrante)

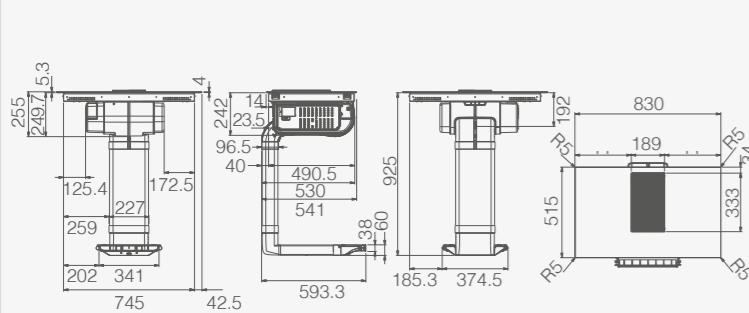

• Nikolatesla Switch - Switch Glow (Aspirante)

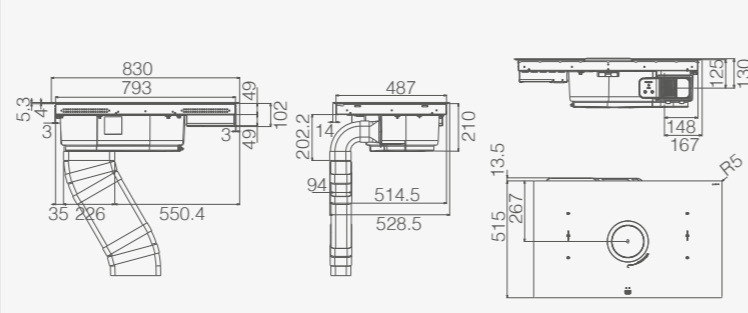

• Nikolatesla Switch - Switch Glow (Filtrante)

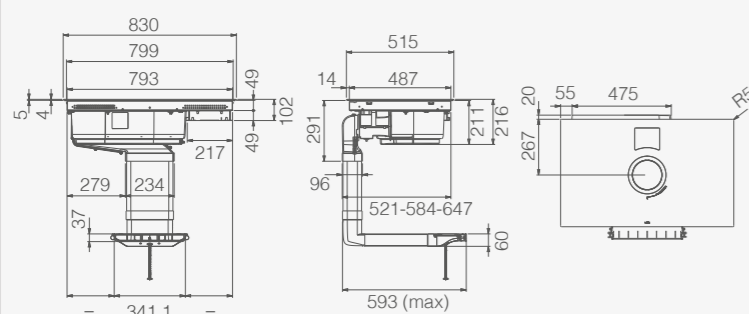

• Nikolatesla Unplugged (Aspirante)

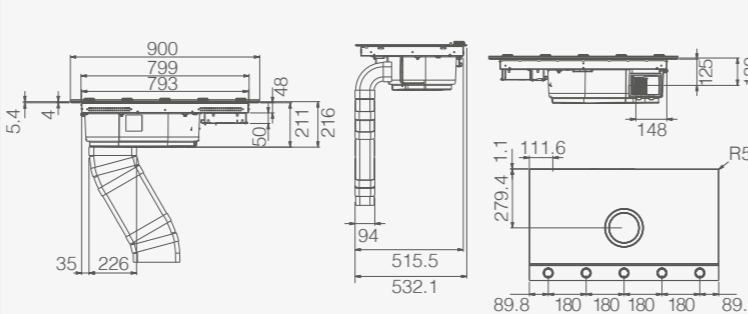

• Nikolatesla Unplugged (Filtrante)

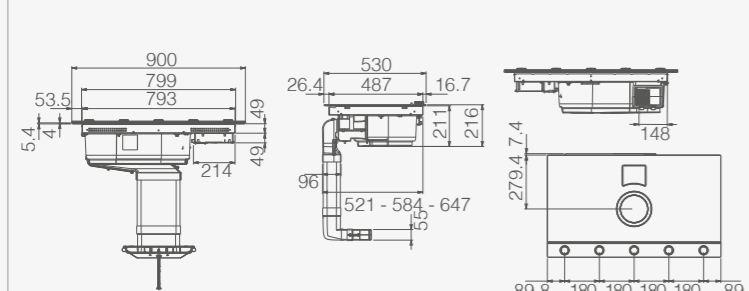

• Nuage

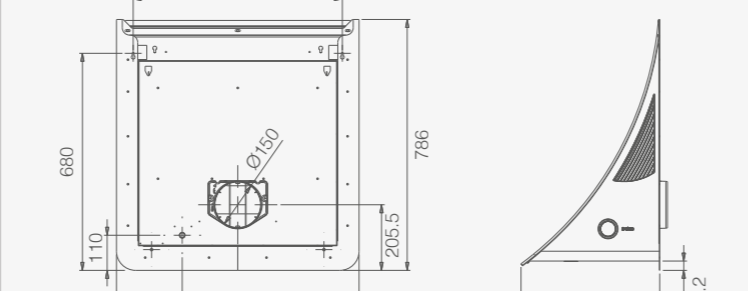

• Om Air

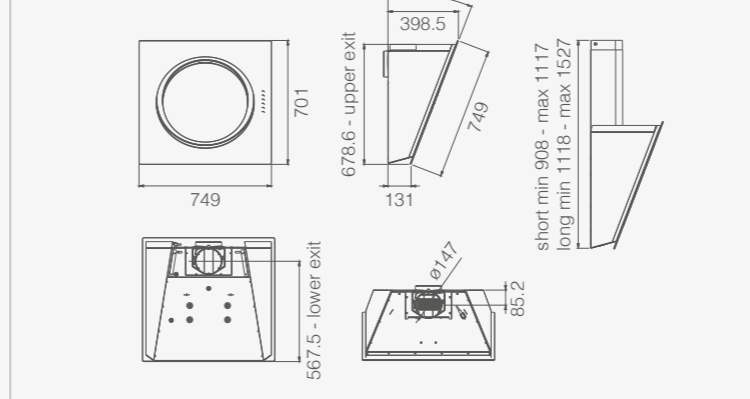

• Open Suite Superior

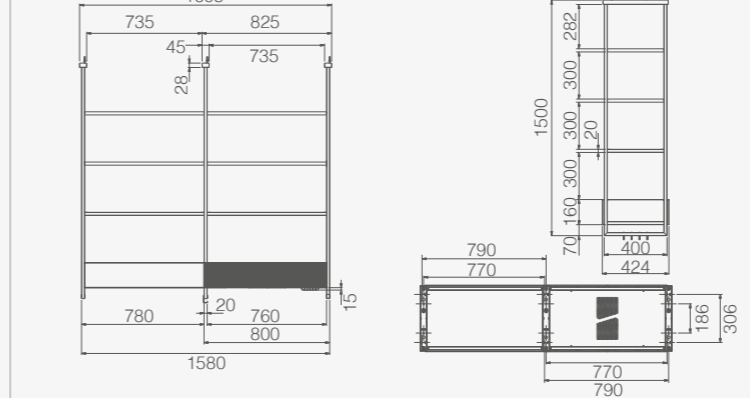

• Open Suite

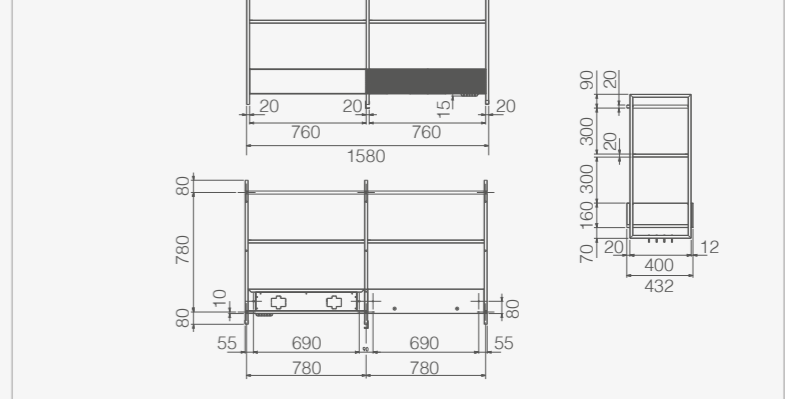

• Pandora

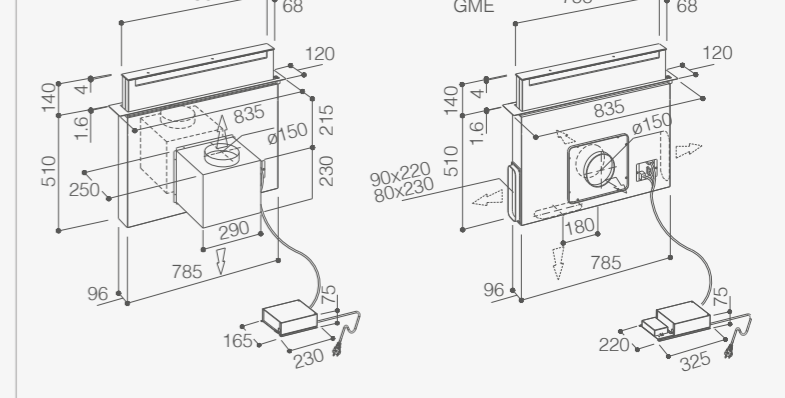

• Pix

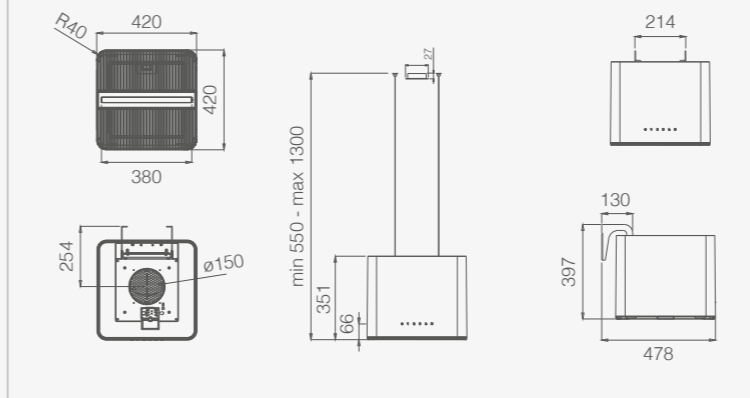

• Plat

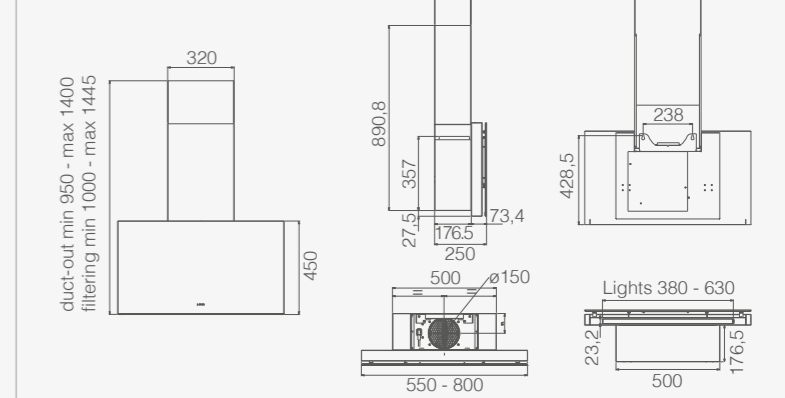

• Reef

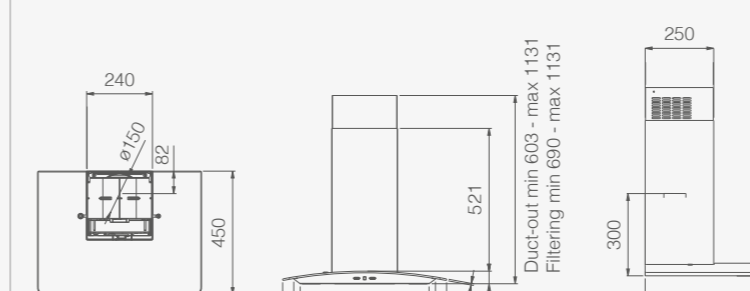

• Reef Island

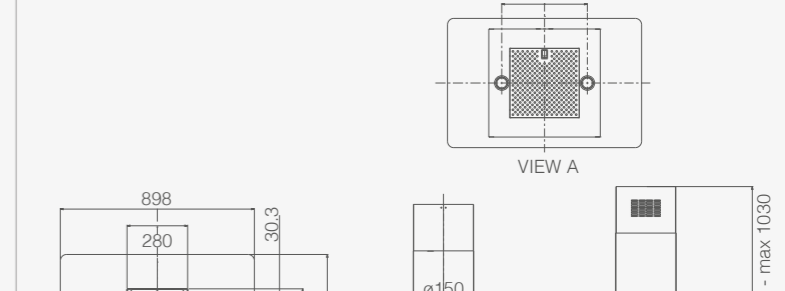

• Rubino Corner

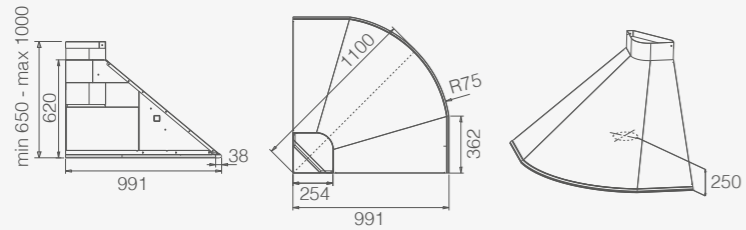

• Rules

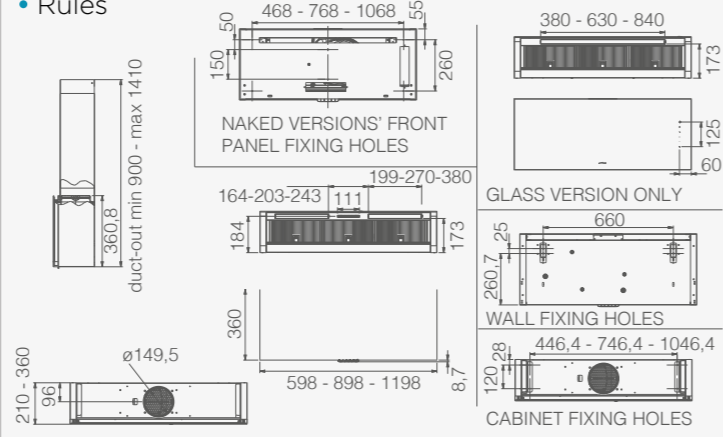

• Skydome (H30)

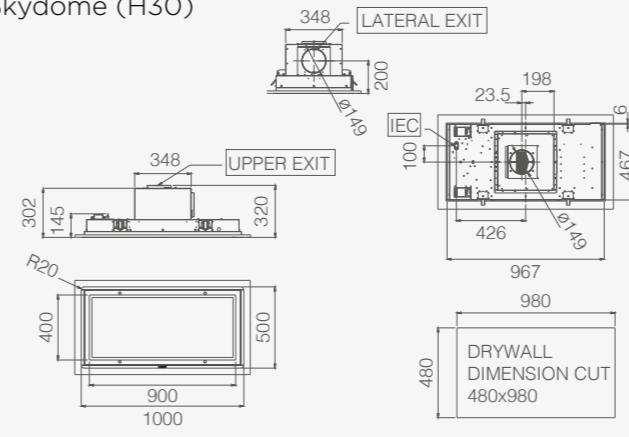

• Skydome (NO MOTOR)

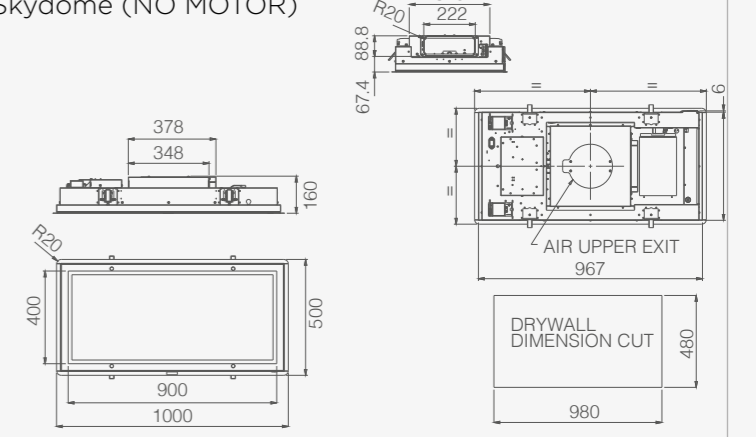

• Seashell

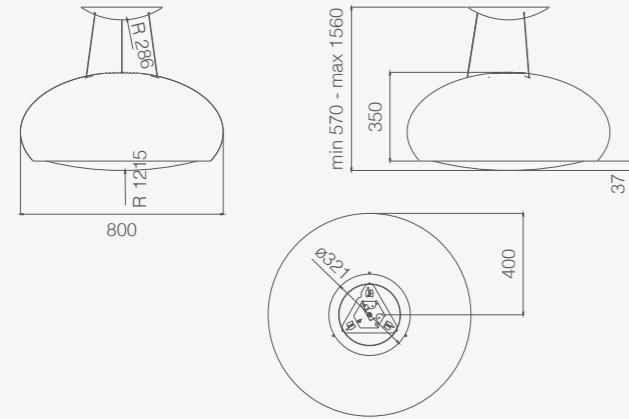

• Sheen-S

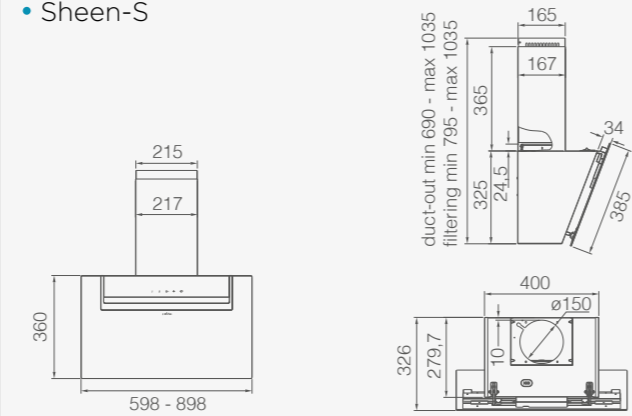

• Spot NG - Spot Plus

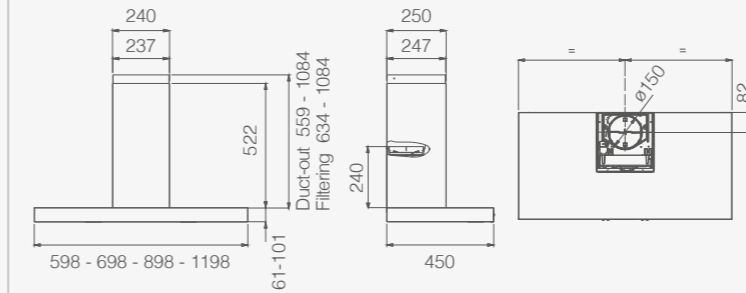

• Spot Urban

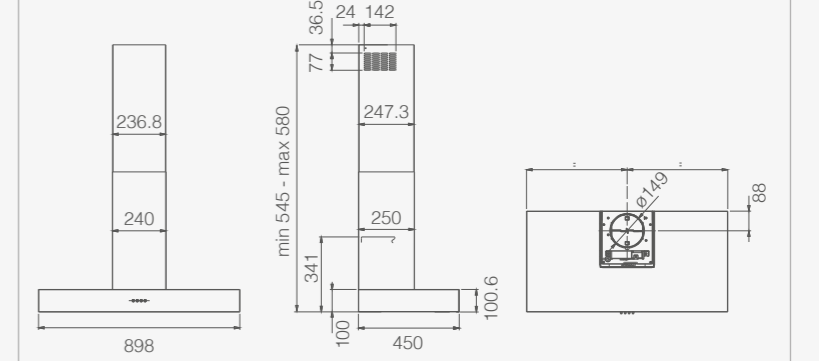

• Shining

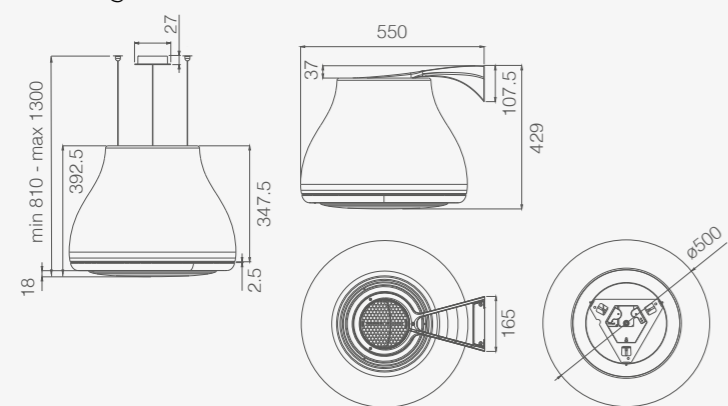

• Shire

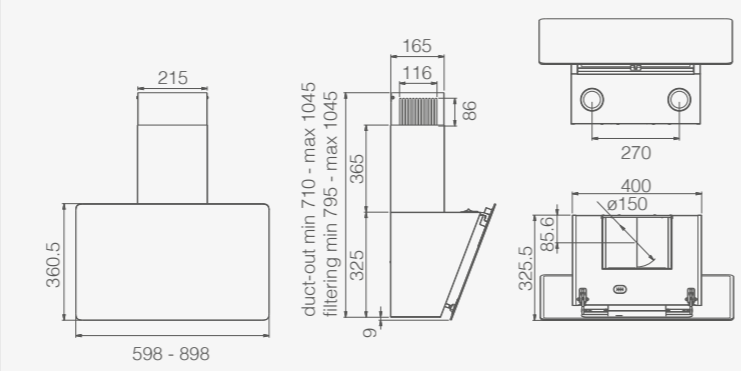

• Spot Plus Island

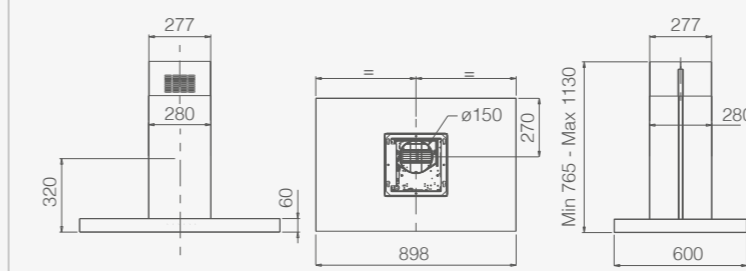

• Stone

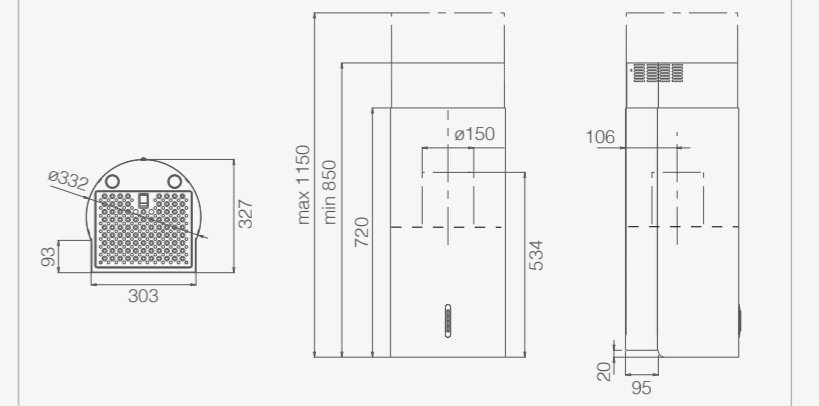

• Shy-S

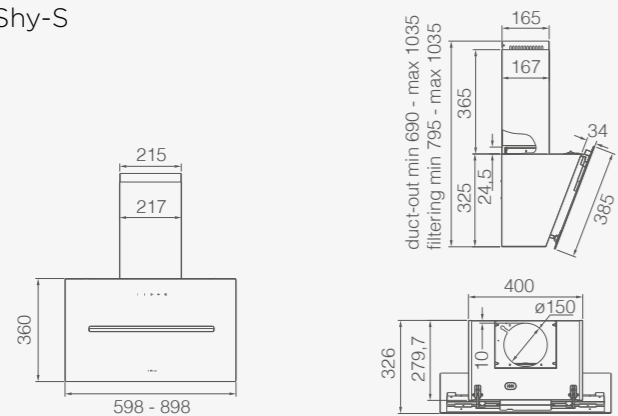

• Skydome (H16)

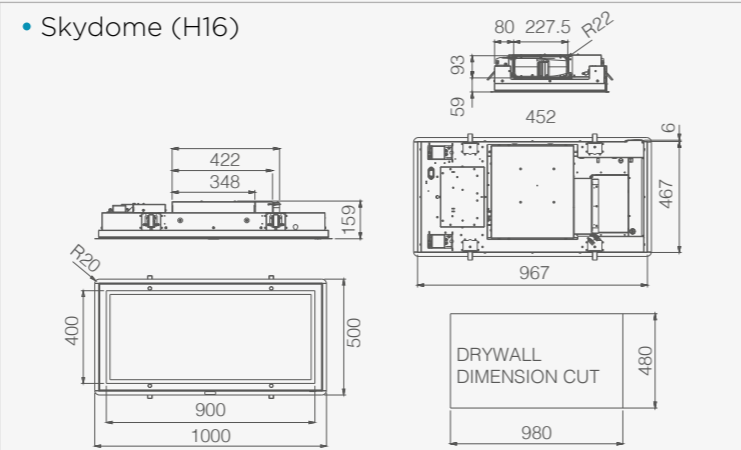

• Stripe

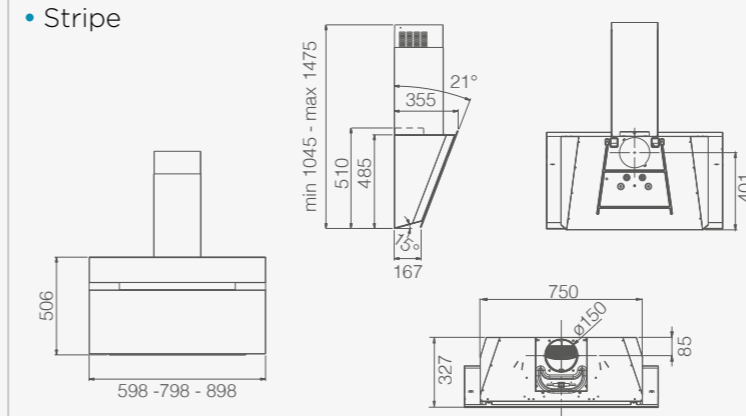

• Stripe Urban

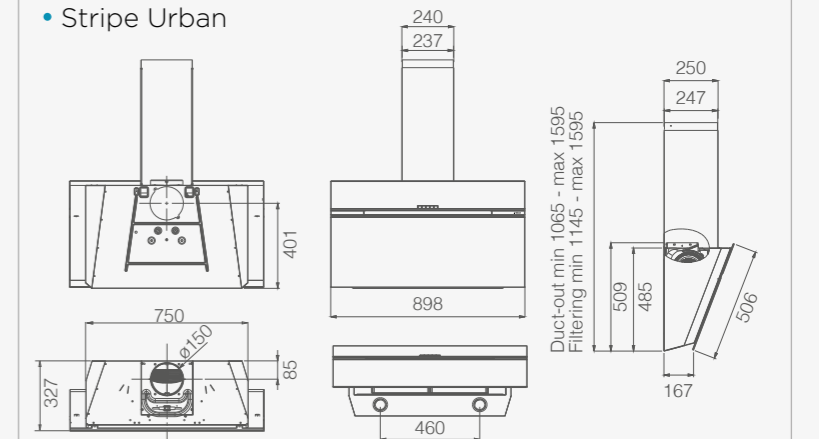

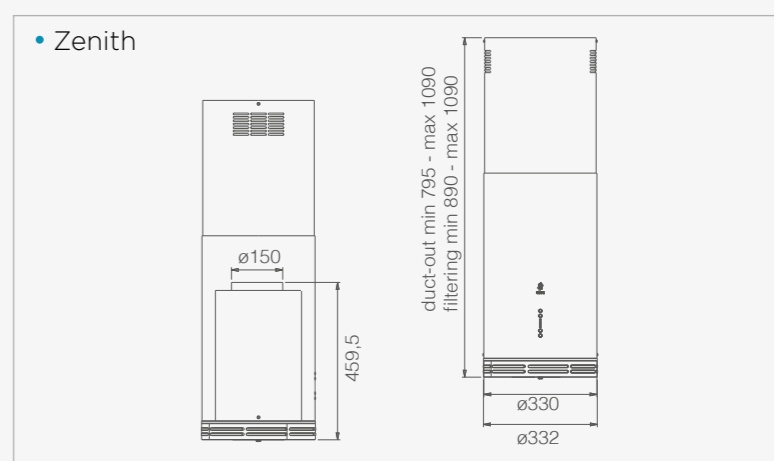
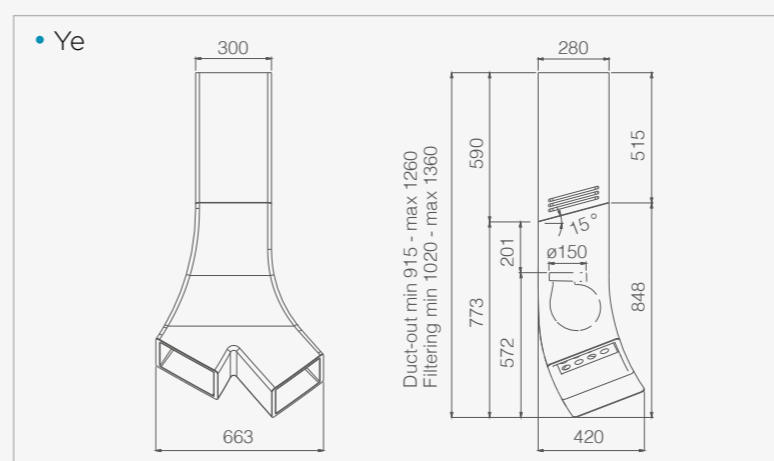
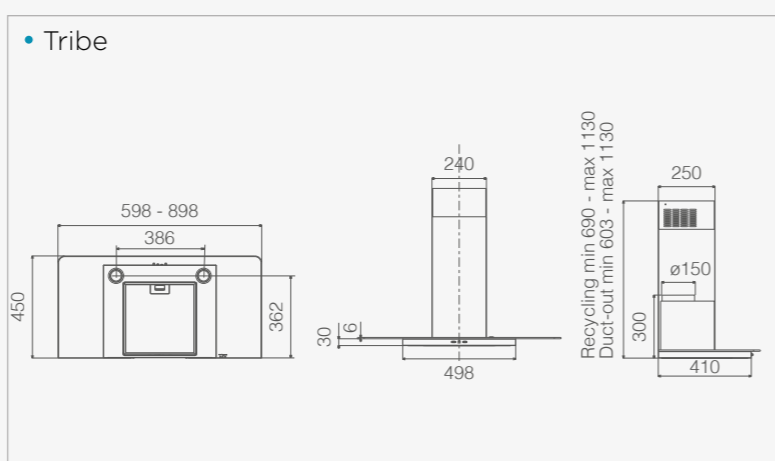
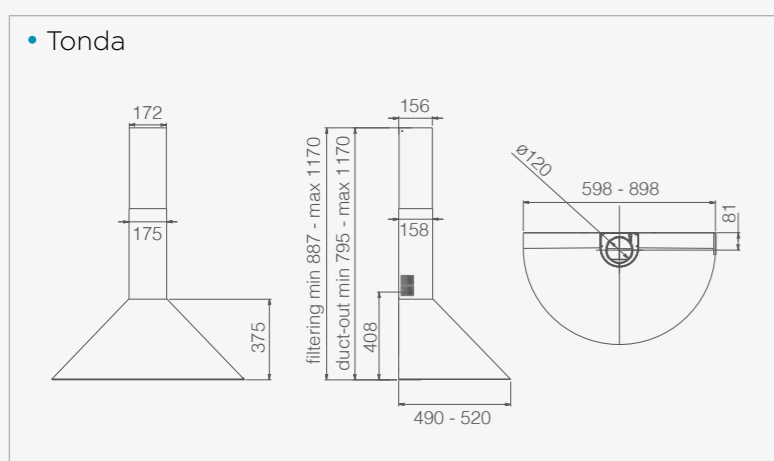
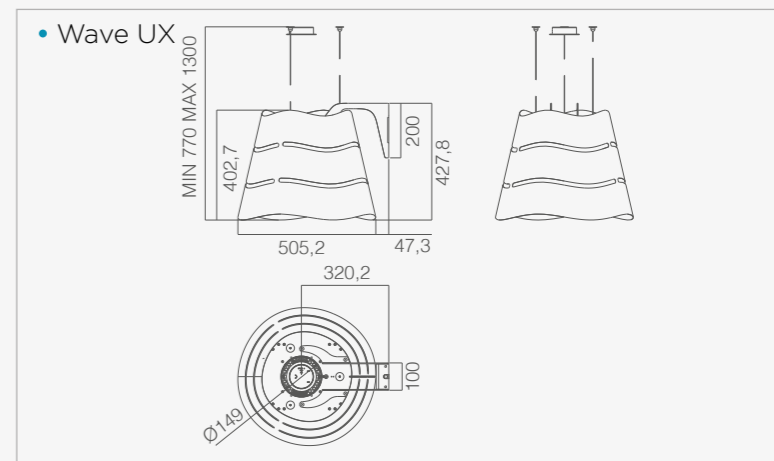
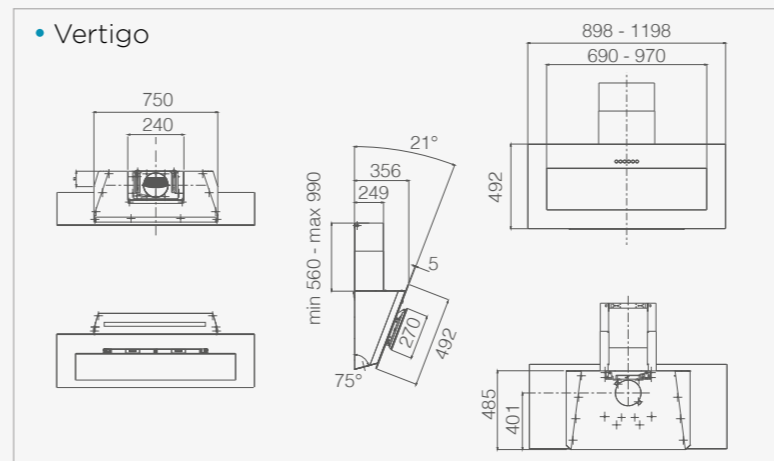
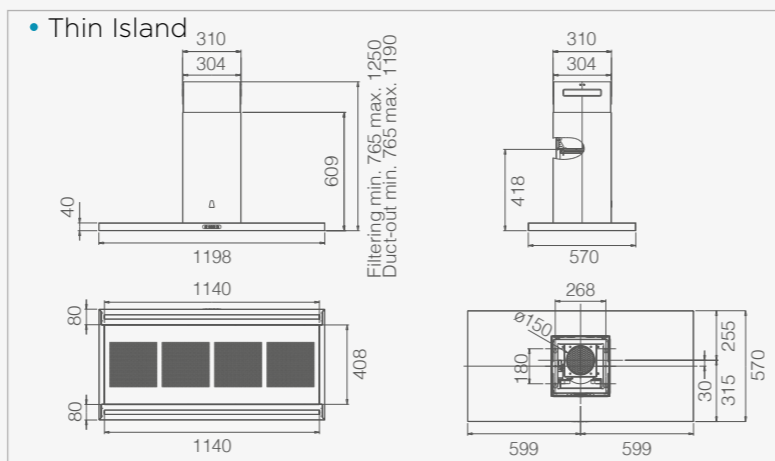
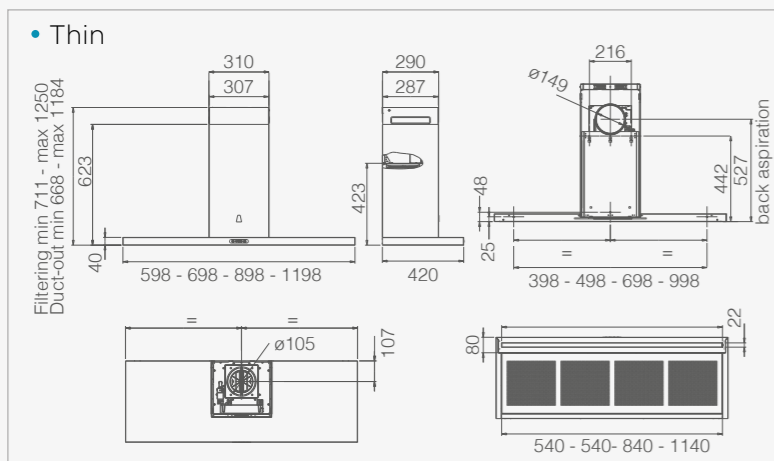
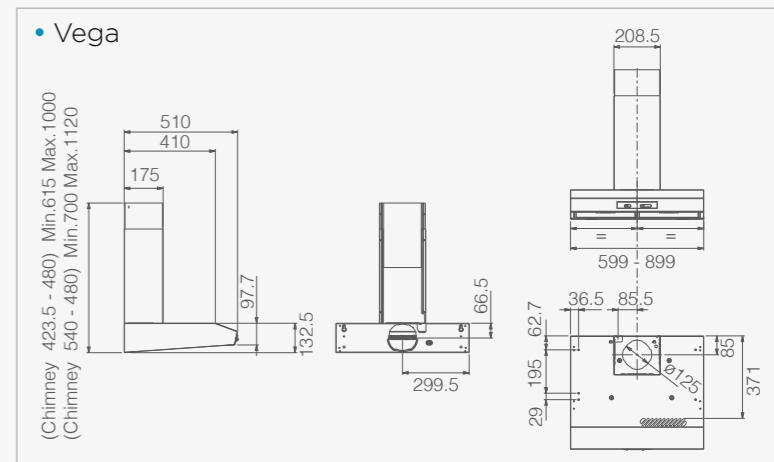
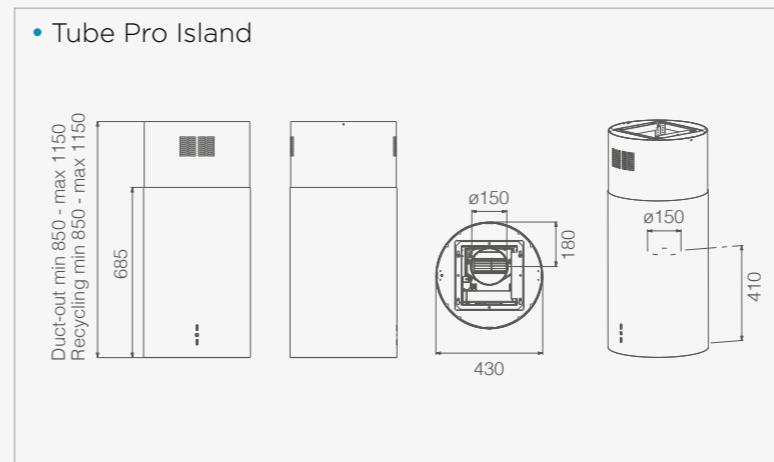
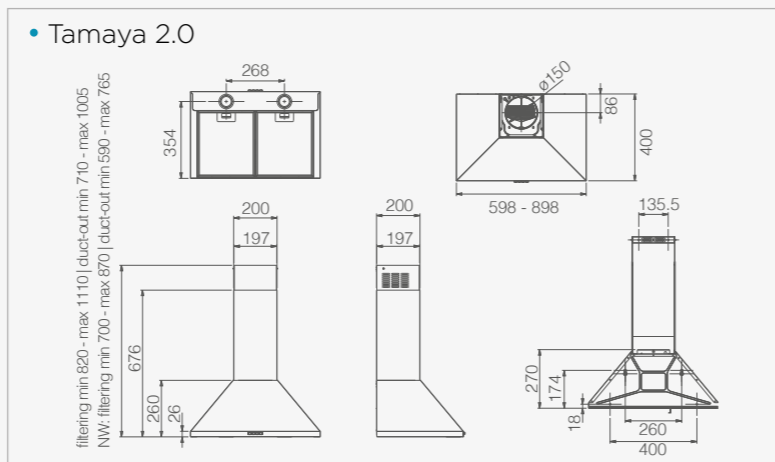
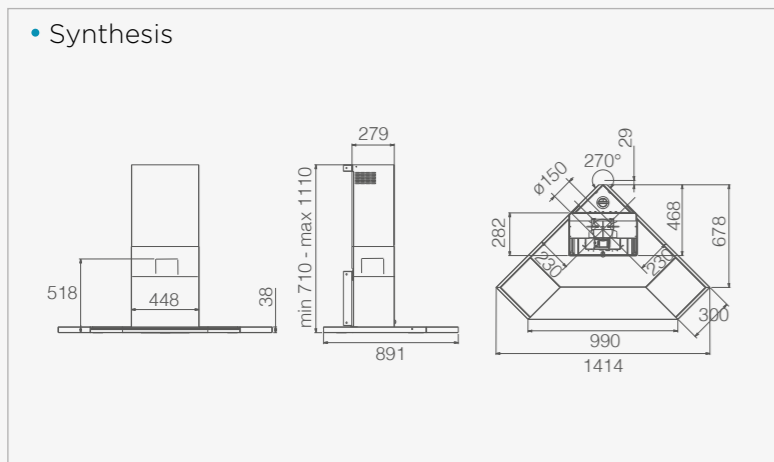
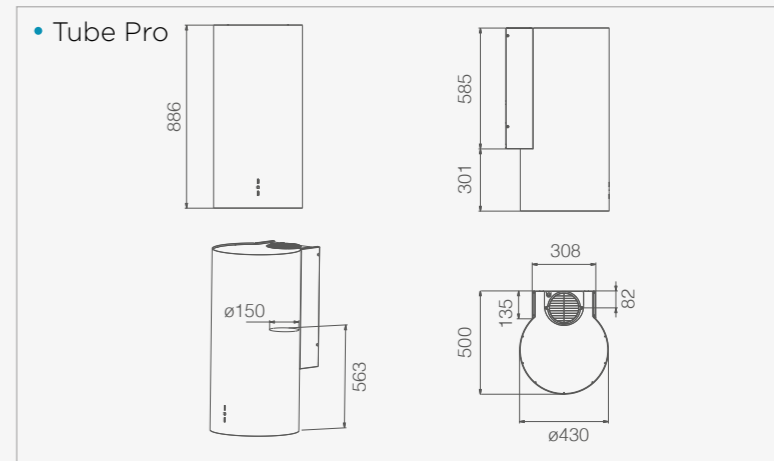
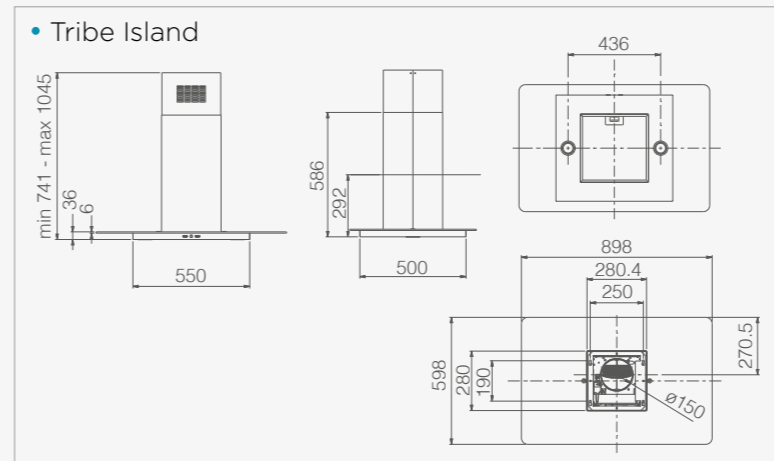
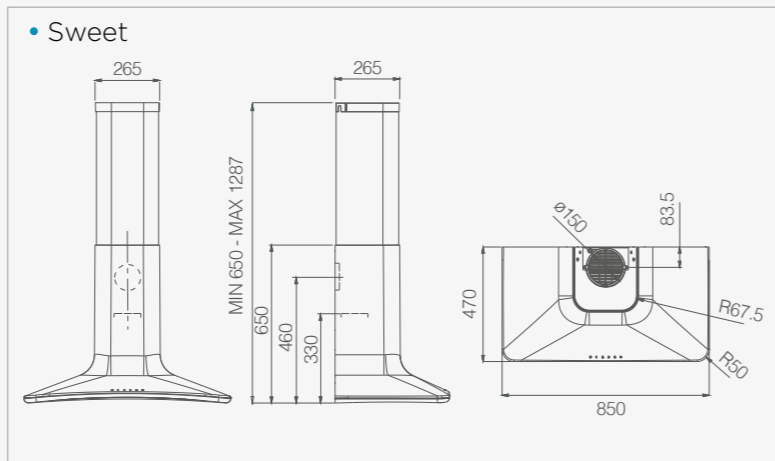
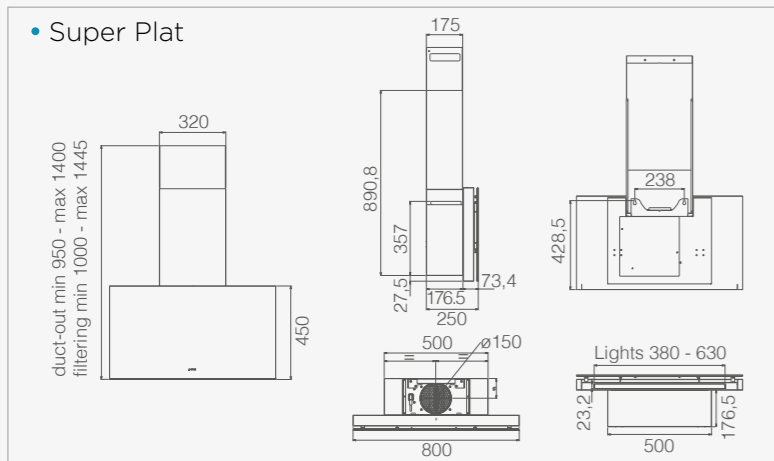

L'IMPORTANZA DELLA CAPPA IN CUCINA THE IMPORTANCE OF THE HOOD IN THE KITCHEN

La cappa è un alleato imprescindibile in cucina per migliorare la qualità dell'aria e mantenere un ambiente sano. I fumi della combustione, i cattivi odori l'odore e i vapori della cottura sono infatti fastidiosi e dannosi non solo per le persone, ma possono deteriorare anche i mobili e le pareti. È quindi importante assicurare una aspirazione efficace, di facile utilizzo e silenziosa che possa rimuoverli lasciando l'ambiente più salubre e pulito.

Eclettica nelle funzioni, la cappa viene oggi utilizzata non solo come fondamentale corpo aspirante, ma anche come fonte luminosa in grado di illuminare al meglio il piano cottura o di creare atmosfere più soffuse, o come vero e proprio complemento d'arredo. I numerosi modelli e finiture disponibili sul mercato permettono di personalizzare l'ambiente in base al design della propria cucina e dei singoli gusti: che sia minimal e lineare o di grande impatto e protagonista, la cappa oggi è diventata un elemento centrale nelle nostre cucine.

The extractor hood is an essential tool in the kitchen, helping to improve air quality and maintain a healthy environment. Combustion fumes, unpleasant smells, odours and cooking vapours are, in fact, both annoying and harmful not only for people, but can also deteriorate furniture and walls. It is, therefore, important to ensure effective, easy-to-use and silent extraction that can eliminate them, leaving the kitchen more hygienic and cleaner. With its eclectic function, the hood is now used not only as a basic extractor unit, but also as a light source to illuminate the hob, to create softer atmospheres or as an authentic furnishing accessory. The numerous models and finishes available on the market allow you to customise the space according to the design of your kitchen and individual taste: whether it is minimal and linear or a statement, signature piece, the hood today has become a central element in our kitchens.

QUALE CAPPA SCEGLIERE? WHICH HOOD SHOULD I CHOOSE?

Tra i tanti modelli disponibili è difficile orientarsi sulla scelta migliore. Per trovare la cappa che più si adatta al proprio ambiente, gusto e stile di vita bisogna tenere in considerazione alcuni fattori principali: corretta potenza di aspirazione, tipologia di installazione, design della cucina. Per ripulire al meglio l'aria, la cappa deve avere la giusta potenza di aspirazione. Valuta le dimensioni della tua cucina e le tue abitudini culinarie. Con un semplice calcolo è possibile definire quale sia la portata ideale per ogni ambiente: basta moltiplicare per 10 il volume della stanza. Facilità di utilizzo e silenziosità sono altre due variabili importanti che ti aiuteranno a vivere una user experience appagante.

It can be difficult to find the best choice among the many models on offer. To find the hood that best suits your space, personal taste and lifestyle, you should consider several key factors: correct extraction power, type of installation and kitchen design. For the best air removal performance, the hood must offer the right extraction power. Take a look at the size of your kitchen and your cooking habits. With a simple calculation, it is possible to define the ideal flow rate for each room: just multiply the room volume by 10. Ease-of-use and silence are another two important variables that will help you achieve the best user experience.

La tipologia di installazione è fondamentale per restringere il campo e indirizzarsi sulla categoria necessaria per la propria cucina.

The type of installation is essential in narrowing the field and finding the category you need for your kitchen.



AD INCASSO BUILT-IN

La cappa è incassata all'interno del pensile, scomparendo alla vista.

The hood is built into the cabinet, disappearing from view.



A PARETE WALL-MOUNTED

La cucina è posizionata contro la parete con il piano cottura in adiacenza al muro. Cappa da installare a parete.

The kitchen is positioned against the wall with the hob adjacent to the wall. Wall-mounted hood.

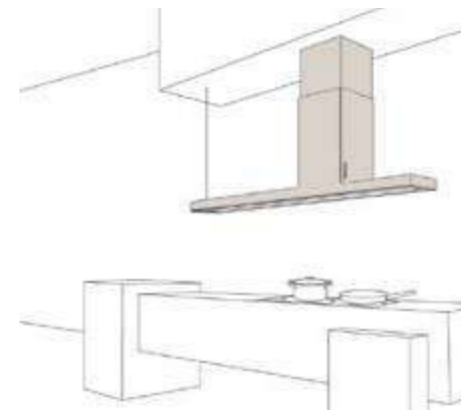

A ISOLA ISLAND

La cucina è posizionata al centro della stanza con il piano cottura distante dal muro. Cappa da installare a soffitto.

The kitchen is positioned in the centre of the room with the hob away from the wall. Ceiling-mounted hood.



AD ANGOLO CORNER

La cucina è sviluppata tra due pareti della stanza e il piano cottura è posizionato a ridosso dell'angolo. Cappa da installare tra le pareti adiacenti.

The kitchen is laid out between two walls of the room and the hob is positioned close to the corner. Install the hood between adjacent walls.



CEILING

La cucina è posizionata o al centro della stanza o contro la parete. La cappa diventa luce e aspirazione e si installa nel controsoffitto.

The kitchen is positioned either in the centre of the room or against the wall. The hood acts as both a light and extractor and is installed in the false ceiling.

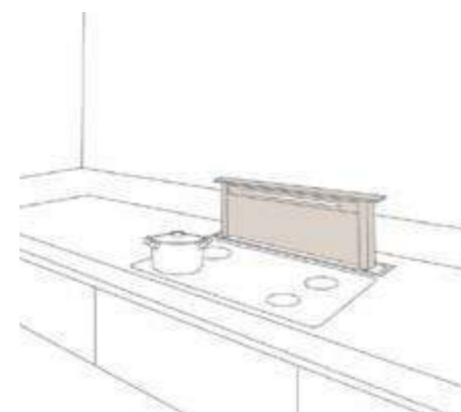

DOWNDRAFT

Il piano cottura è posizionato distante dal muro, su un bancone a penisola o al centro della stanza. Cappa da installare direttamente sul top.

The hob is positioned away from the wall, on a peninsula counter or in the centre of the room. Install the hood directly on the top.



SOSPESA SUSPENDED

Cappa da installare a soffitto, a sospensione come un lampadario.

Install the hood on the ceiling, suspended like a pendant light.



**PIANO COTTURA ASPIRANTE
EXTRACTOR HOB**

La cappa è integrata nel piano cottura. Aspirazione dal basso.

The hood is integrated into the hob. Extraction from below

COME INSTALLARLA? HOW IS IT INSTALLED?

Il perfetto funzionamento della cappa è assicurato da una corretta installazione, garantita da personale specializzato. Il montaggio e la manutenzione variano in base alle due tipologie di cappa: aspirante e filtrante. Molti i modelli Elica sono predisposti per lavorare in entrambe le versioni. Prima di procedere all'installazione della tua cappa, tieni a mente queste semplici regole di base:

- Segui tutte le fasi indicate nel libretto di istruzioni;
- Collega la cappa aspirante all'esterno con una tubazione dedicata dal diametro 120-150mm: una lunghezza ridotta e l'assenza di curvature garantiscono prestazioni ottimali.
- Rispetta la distanza minima dal piano cottura indicata nel libretto, al fine di evitare danni alle parti funzionali e salvaguardare la sicurezza delle persone;
- Controlla che la posizione della presa elettrica sia in prossimità del prodotto per il collegamento;
- In caso di difficoltà richiedi l'intervento di un tecnico specializzato di tua fiducia.

Perfect hood operation is ensured by correct installation, guaranteed by specialised personnel. Assembly and maintenance vary according to the two types of hood: extractor and filter. Many Elica models are designed to work in both versions. Before starting installation of your hood, bear in mind these simple, basic rules:

- Follow all the steps indicated in the instruction booklet;
- Connect the extractor hood to the outside using a dedicated pipe with a diameter of 120-150mm: a shorter length and the absence of bends guarantee the best performance.
- Respect the minimum distance from the hob indicated in the booklet to avoid damage to the operational parts and protect personal safety;
- Ensure that the location of the electrical outlet is close to the product for connection;
- In case of difficulty, request the intervention of a specialised technician.

CAPPA FILTRANTE FILTER HOOD

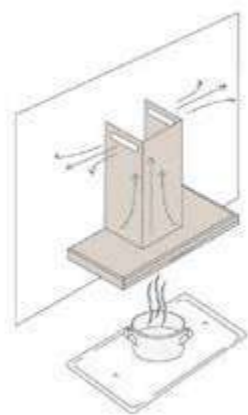

La cappa filtrante elimina fumi e cattivi odori attraverso i filtri dedicati e reimmette l'aria ripulita nell'ambiente cucina. Questa tipologia è adatta in situazioni prive del foro di evacuazione all'esterno.

The filter hood eliminates fumes and unpleasant odours via dedicated filters and returns clean air to the kitchen. This type of hood is suitable in situations without no external evacuation hole.

CAPPA ASPIRANTE EXTRACTOR HOOD

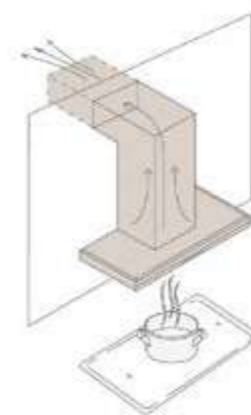

La cappa aspirante espelle l'aria all'esterno dell'abitazione. È la tipologia più diffusa in quanto garantisce elevate prestazioni, alta portata e bassa rumorosità.

The extractor hood expels the air outside the home. It is the most common type as it guarantees high performance, high flow rate and minimum noise.

MANUTENZIONE MAINTENANCE

Per assicurare una lunga durata e un corretto funzionamento della tua cappa, il primo passo è mantenere in ottimo stato il sistema di filtraggio.

To ensure that your hood lasts for a long time and continues to work correctly, the first step is to keep the filtering system in tip-top condition.

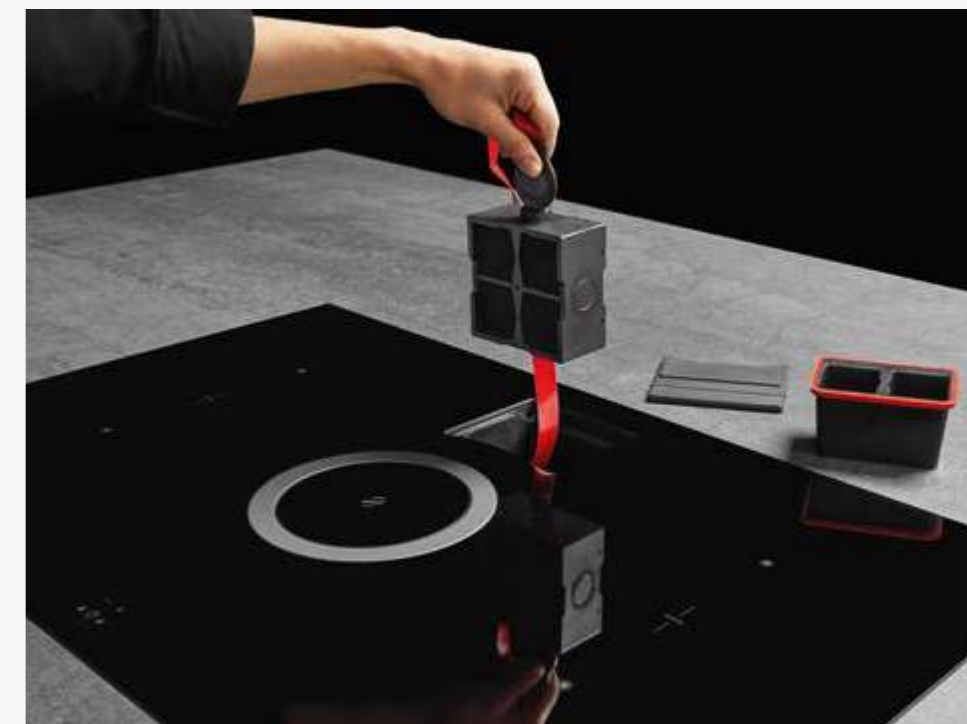

Le cappe filtranti prevedono due tipologie di filtro: il filtro grassi, che ripulisce l'aria dai grassi dispersi durante la cottura, e il filtro odori. Entrambi vanno regolarmente puliti e sostituiti per assicurare performance sempre alte.

- Il filtro grassi protegge la tua cappa trattenendo le particelle di grasso. Il filtro grassi può essere in versione alluminio o inox e richiede una pulizia periodica a mano con detergente neutro o in lavastoviglie a basse temperature (*), oppure in carta. In questo caso va sostituito ogni mese in base all'utilizzo.
- Il filtro odori, a carboni attivi, installato sulle cappe filtranti, cattura e trattiene le particelle odorose dell'aria. Ricorda di sostituirlo ogni 3-4 mesi. I filtri odori long life hanno invece una durata maggiore: sono infatti rigenerabili, possono essere lavati e asciugati e sostituiti ogni due anni. Bastano semplici e piccole accortezze per mantenere sana ed efficiente la tua cappa nel tempo.

(*) Verificare sempre come lavare il filtro sul libretto d'istruzione del prodotto

Filter hoods feature two types of filter: the grease filter which removes the grease from the air dispersed during cooking and the odour filter. Both must be regularly cleaned and replaced to ensure the very best performance.

- The grease filter protects your hood by trapping grease particles. The grease filter can be made of aluminium or stainless steel and requires periodic cleaning by hand with a neutral detergent or in the dishwasher at a low temperature (*), or alternatively in a paper version. In this case, it must be replaced every month based on use.
- The odour filter with activated carbon, installed on filter hoods, captures and traps odour particles in the air. Remember to replace it every 3-4 months. Long-life odour filters, on the other hand, last longer. They can, in fact, be regenerated and washed, dried and replaced every two years. A few simple, minor precautions are all it takes to keep your hood hygienic and working efficient over time.

(*) Always check how to wash the filter in the product instruction booklet

ETICHETTA ENERGETICA ENERGY LABEL

L'Etichetta Energetica è uno strumento fondamentale per scegliere la cappa aspirante più idonea alle proprie esigenze. Dalla sua lettura è possibile ottenere immediatamente informazioni non solo in merito ai suoi consumi di energia, ma anche un quadro semplice e chiaro dell'efficienza con cui essa espleta le sue funzioni.

In ciascuna pagina del catalogo trovate un simbolo che indica la Classe Energetica del prodotto presentato.

Per ottenere informazioni dettagliate di ciascuna versione del modello di interesse, tra cui tutti i parametri riportati nell'etichetta energetica, procedere come segue:

- Identificare il **codice del prodotto** di interesse
- Nel sito web **www.elica.com** accedere alla sezione DOWNLOADS dell'area ASSISTENZA, inserire il codice del prodotto nell'apposito campo di ricerca e scaricare il documento PDF (Product Fiche) che riporta tutte le caratteristiche del prodotto, in accordo ai regolamenti EU n° 65/2014 e 66/2014.

The Energy Label constitutes a fundamental tool for choosing the most suitable extractor hood for the user's needs. The label provides instant information on energy consumption and the level of efficiency of the product's performances.

Each page of our catalogue contains a symbol indicating the energy class of the product presented.

For obtaining detailed information on each version of the desired model, including all the parameters appearing on the energy label, proceed as follows:

- Identify the **product code** of the relevant model
- Visit the website **www.elica.com** and go to the DOWNLOADS section of the ASSISTANCE page, insert the product code in the search field and download the PDF document (Product Fiche) listing all the product characteristics, as per EU regulations no. 65/2014 and 66/2014.

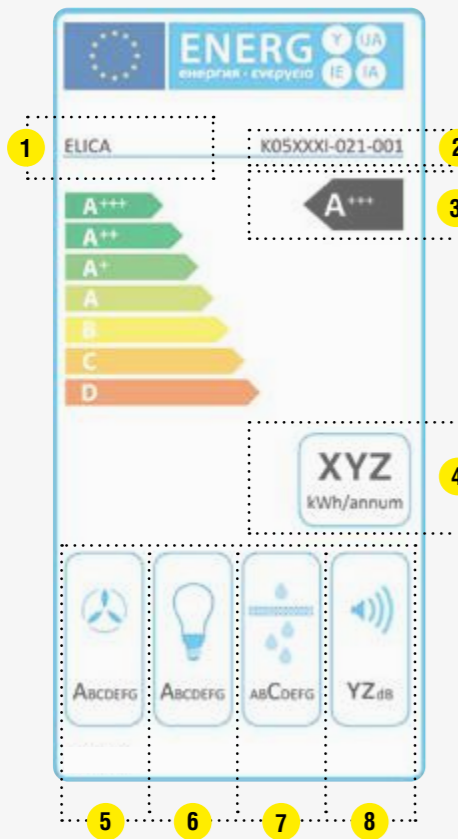

1	NOME O MARCHIO DEL FORNITORE	SUPPLIER NAME OR BRAND.
2	IDENTIFICATIVO DEL MODELLO	MODEL IDENTIFICATION CODE.
3	CLASSE DI EFFICIENZA ENERGETICA A/A+/A++/A+++ Massima efficienza - D Minima.	ENERGY EFFICIENCY CLASS A/A+/A++/A+++ Maximum efficiency - D Minimun.
4	CONSUMO ANNUO DI ENERGIA STIMATO Per utilizzo standard.	ESTIMATED ANNUAL ENERGY CONSUMPTION For standard use
5	CLASSE DI EFFICIENZA FLUIDODINAMICA Indica l'efficienza con cui la cappa è in grado di aspirare i vapori generati dalla cottura. A Massima efficienza - G Minima.	FLUID DYNAMIC EFFICIENCY CLASS Indicates the efficiency with which the hood is able to extract vapours through cooking A Maximum efficiency - G Minimun.
6	CLASSE DI EFFICIENZA LUMINOSA Indica l'efficienza con cui la cappa illumina il piano cottura. A Massima efficienza - G Minima.	LIGHTING EFFICIENCY CLASS Indicates the efficiency with which the hood is able to illuminate the cooker hob A Maximum efficiency - G Minimun.
7	CLASSE EFFICIENZA FILTRAGGIO GRASSI Indica l'efficienza con cui la cappa filtra i grassi generati dalla cottura. A Massima efficienza - G Minima.	GREASE FILTERING EFFICIENCY CLASS Indicates the efficiency with which the hood filters grease generated through cooking A Maximum efficiency - G Minimun.
8	LIVELLO DI RUMOROSITÀ Indica il massimo livello di rumore generato dal prodotto nell'utilizzo normale.	NOISE LEVEL Indicates the maximum noise level generated by the product during normal use

BENVENUTO NEL SERVICE DI ELICA WELCOME TO ELICA SERVICE

NUMERO ASSISTENZA 02.382.93.009

Un centro di supporto specializzato a disposizione dal lunedì al venerdì dalle 08:00 alle 20:00 e il sabato dalle 08:00 alle 14:00.

E-MAIL PER ASSISTENZA TECNICA
trade.italia@elica.com

CENTRI ASSISTENZA

Il Service di Elica, attraverso un network composto da 170 service partner selezionati, garantisce una copertura capillare del territorio nazionale.

SUPPORTO DEDICATO SU ELICA.COM

È possibile eseguire il download dei libretti di istruzioni direttamente su elica.com. Inoltre, per ulteriori approfondimenti, è disponibile un assistente virtuale nella sezione "Assistenza/Contattaci".

ACCESSORI E RICAMBI ORIGINALI

Una corretta manutenzione e la regolare sostituzione dei filtri carbone sono fondamentali per garantire il perfetto funzionamento dei nostri prodotti.

I filtri carbone e grassi, gli accessori (es. tubazioni, telecomandi e lampade) e i prodotti per la pulizia sono disponibili su shop.elica.com

GARANZIA 24 MESI

Tutti i prodotti Elica godono della garanzia legale di 2 anni a partire dalla data di acquisto del prodotto.

EXTRAGARANZIA

Per maggiori informazioni chiama il numero assistenza 02.382.93.009 o collegati al sito www.elica.com

SERVICE NUMBER 02.382.93.009

A specialized support center available from Monday to Friday from 8 am to 8 pm and on Saturday from 8 am to 2 pm.

EMAIL FOR TECHNICAL SUPPORT
trade.italia@elica.com

SERVICE CENTRES

Elica's service, through a network of 170 selected service partners, guaranteeing widespread coverage throughout Italy.

DEDICATED SUPPORT ON ELICA.COM

Instruction handbooks can be downloaded directly on elica.com. For further information, a virtual assistant is also available at the "Assistance/Contact us" section.

ACCESSORIES AND ORIGINAL SPARE PARTS

Proper maintenance and the regular replacement of the carbon filters is essential in guaranteeing the perfect operation of our products.

Carbon and grease filters, accessories (ex. pipings, remote controls and lamps) and cleaning products are available on shop.elica.com.

24-MONTH WARRANTY

All Elica products enjoy a 2-year manufacturer's warranty, effective from the date of purchase.

EXTRA WARRANTY

For further information please call customer assistance at 02.382.93.009, or visit www.elica.com



REALIZED BY ELICA TEAM
BARBARA PERSIGILLI
FRANCESCA POETA
Graphic Design
and Coordination

IN COLLABORATION WITH

MMG - GALLARATE
Project Art Direction

ARCHÈ AGENCY - PESARO
Scenic Art Direction
Photorealistic 3D

SELECOLOR - FIRENZE
Post Production
Color Separation

GRAFICHE ANTIGA - TREVISO
Printing



**Il catalogo è proprietà di Elica spa. Tutti i diritti sono riservati.
È vietata ogni forma di riproduzione anche parziale.**

This catalogue is of exclusive property of Elica spa.
All rights are reserved. Any form of total or partial reproduction of
catalogue is strictly forbidden.

**La stampa tipografica non sempre riproduce fedelmente le tinte ed i
materiali originali.**

The printing process do not always permit a faithful reproducton of
tones and materials of originals.

**Elica si riserva di apportare modifiche ai dati e ai dettagli dei
prodotti presenti su questo catalogo anche senza preavviso.**

Elica may at any time modify the specifications and details of the
products present in the catalogue.

NOVEMBRE 2022
November 2022

Elica
Via Ermanno Casoli, 2
60044 Fabriano AN Italy
T +39 0732 6101
F +39 0732 610249



elica.com